

# OPERATOR MANUAL

IMPORTANT INFORMATION, KEEP FOR OPERATOR

This manual provides information for:

**smartsteam™**  
BOILERLESS STEAMER **100**

## **MODELS SSB-3E/5E/10E & (2)SSB-3E/5E/10E Domestic SMARTSTEAM100™ BOILERLESS STEAMER**

- Self Contained
- Electric Heated
- Capacity: SSB-3E=3 Steamer Pans Per Cavity  
SSB-5E=5 Steamer Pans Per Cavity  
SSB-10E=10 Steamer Pans Per Cavity



**THIS MANUAL MUST BE RETAINED FOR FUTURE REFERENCE.  
READ, UNDERSTAND AND FOLLOW THE INSTRUCTIONS AND  
WARNINGS CONTAINED IN THIS MANUAL.**

### **FOR YOUR SAFETY**

Do not store or use gasoline or other flammable vapors and liquids in the vicinity of this or any other appliance.

### **NOTIFY CARRIER OF DAMAGE AT ONCE**

It is the responsibility of the consignee to inspect the container upon receipt of same and to determine the possibility of any damage, including concealed damage. Unified Brands suggests that if you are suspicious of damage to make a notation on the delivery receipt. It will be the responsibility of the consignee to file a claim with the carrier. We recommend that you do so at once.

Manufacture Service/Questions 888-994-7636.

Information contained in this document is known to be current and accurate at the time of printing/creation. Unified Brands recommends referencing our product line websites, [unifiedbrands.net](http://unifiedbrands.net), for the most updated product information and specifications.

PART NUMBER 145145, REV. M (1/16)

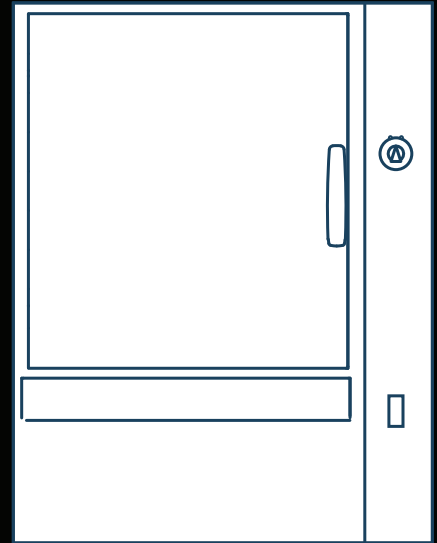

1055 Mendell Davis Drive  
Jackson, MS 39272  
888-994-7636, fax 888-864-7636  
[unifiedbrands.net](http://unifiedbrands.net)

## **IMPORTANT — READ FIRST — IMPORTANT**

- WARNING:** THE UNIT MUST BE INSTALLED BY PERSONNEL QUALIFIED TO WORK WITH ELECTRICITY AND PLUMBING. IMPROPER INSTALLATION CAN CAUSE INJURY TO PERSONNEL AND/OR DAMAGE TO THE EQUIPMENT. THE UNIT MUST BE INSTALLED IN ACCORDANCE WITH APPLICABLE CODES.
- CAUTION:** SHIPPING STRAPS ARE UNDER TENSION AND CAN SNAP BACK WHEN CUT.
- CAUTION:** DO NOT INSTALL THE UNIT IN ANY WAY WHICH WILL BLOCK THE REAR VENTS, OR WITHIN 2 INCHES OF A HEAT SOURCE SUCH AS A BRAISING PAN, DEEP FRYER, CHAR BROILER OR KETTLE.
- CAUTION:** LEVEL THE UNIT FRONT TO BACK, AND PITCH IT SLIGHTLY TO THE FRONT, TO AVOID DRAINAGE PROBLEMS.
- WARNING:** FOLLOW THE WIRING DIAGRAM EXACTLY WHEN CONNECTING A UNIT TO AVOID DAMAGE OR INJURY. WIRING DIAGRAM IS LOCATED ON THE INSIDE OF THE RIGHT PANEL.
- CAUTION:** DO NOT USE PLASTIC PIPE. DRAIN MUST BE RATED FOR BOILING WATER.
- WARNING:** DO NOT CONNECT THE DRAIN DIRECTLY TO A BUILDING DRAIN.
- WARNING:** BLOCKING THE DRAIN IS HAZARDOUS.
- IMPORTANT:** IMPROPER DRAIN CONNECTION WILL VOID WARRANTY.
- IMPORTANT:** DO NOT ALLOW ANY WATER TRAPS IN THE DRAIN LINE. A TRAP CAN CAUSE PRESSURE TO BUILD UP INSIDE THE CAVITY DURING STEAMING, WHICH WILL MAKE THE DOOR GASKET LEAK.
- WARNING:** WHEN YOU OPEN THE DOOR, STAY AWAY FROM STEAM COMING OUT OF THE UNIT. STEAM CAN CAUSE BURNS.
- WARNING:** BEFORE CLEANING THE OUTSIDE OF THE STEAMER, DISCONNECT THE ELECTRIC POWER SUPPLY. KEEP WATER AND CLEANING SOLUTIONS OUT OF CONTROLS AND ELECTRICAL COMPONENTS. NEVER HOSE OR STEAM CLEAN ANY PART OF THE UNIT.
- WARNING:** ALLOW COOKING CHAMBER TO COOL COMPLETELY BEFORE CLEANING.
- WARNING:** USE MILD CLEANING AGENTS ONLY. CAREFULLY READ THE WARNINGS AND FOLLOW THE DIRECTIONS ON THE LABEL OF EACH CLEANING AGENT. USE SAFETY GLASSES AND RUBBER GLOVES AS RECOMMENDED BY CLEANING AGENT MANUFACTURER.
- WARNING:** DO NOT PUT HANDS OR TOOLS INTO THE COOKING CHAMBER UNTIL THE FAN HAS STOPPED TURNING.
- WARNING:** DO NOT OPERATE THE UNIT UNLESS THE REMOVABLE RIGHT SIDE PANEL HAS BEEN RETURNED TO ITS PROPER LOCATION.
- NOTICE:** DO NOT USE A CLEANING AGENT THAT CONTAINS ANY SULFAMIC ACID, OR ANY CHLORIDE, INCLUDING HYDROCHLORIC ACID. IF THE CHLORIDE CONTENT OF ANY PRODUCT IS UNCLEAR, CONSULT THE MANUFACTURER. DO NOT USE A CLEANING OR DELIMING AGENT THAT CONTAINS MORE THAN 30% PHOSPHORIC ACID.
- NOTICE:** DO NOT USE ANY DEGREASER THAT CONTAINS POTASSIUM HYDROXIDE OR SODIUM HYDROXIDE OR THAT IS ALKALINE.
- WARNING:** USE OF ANY REPLACEMENT PARTS OTHER THAN THOSE SUPPLIED BY GROEN OR THEIR AUTHORIZED DISTRIBUTOR VOIDS ALL WARRANTIES AND CAN RESULT IN BODILY INJURY TO THE OPERATOR AND DAMAGE THE EQUIPMENT. SERVICE BY OTHER THAN FACTORY-AUTHORIZED PERSONNEL WILL VOID ALL WARRANTIES.
- WARNING:** HIGH VOLTAGE EXISTS INSIDE CONTROL COMPARTMENTS. DISCONNECT FROM BRANCH CIRCUIT BEFORE SERVICING. FAILURE TO DO SO CAN RESULT IN INJURY OR DEATH.

# Table of Contents

OPERATOR WARNINGS.....	2
REFERENCES.....	3
EQUIPMENT DESCRIPTION.....	4
INSPECTION AND UNPACKING .....	4
INSTALLATION AND STARTUP .....	5-8
OPERATION .....	8-9
CLEANING.....	9-10
MAINTENANCE.....	11-12
TROUBLESHOOTING .....	13-14
PARTS LIST.....	15
WIRING DIAGRAM.....	21
SERVICE LOG .....	23
WARRANTY PROTECTION .....	24

## References

UNDERWRITERS LABORATORIES, INC.  
333 Pfingsten Road  
Northbrook, Illinois 60062-2096

NATIONAL FIRE PROTECTION ASSOCIATION  
1 Batterymarch Park  
Quincy, Massachusetts 02169-7471

NFPA/70 National Electrical Code

NSF INTERNATIONAL  
789 N. Dixboro Rd.  
P.O. Box 130140  
Ann Arbor, Michigan 48105-9723

## Equipment Description

Your Groen SSB-3E/5E/10E or (2)SSB-3E/5E/10E SmartSteam100 Boilerless Steamer is designed to give years of service. It has a stainless steel cavity (cooking chamber) which is served by an electric-heated atmospheric steam generating reservoir. A powerful blower circulates the steam in the cavity to increase heating efficiency.

Each cavity holds up to three, five or ten steam table pans (12" x 20" x 2 1/2" deep) as shown below.

SSB Steamer	PANS PER CAPACITY PER TYPE			
	12 x 20 x 2-1/2 (steamer)	12 x 20 x 4 (steamer)	13 x 18 (half size bake)	18 x 26 (bake)
SSB-3E	3	2	0	0
(2)SSB-3E	6	4	0	0
SSB-5E	5	3	0	0
(2)SSB-5E	10	6	0	0
SSB-10E	10	6	20	10
(2)SSB-10E	20	12	40	20

An 18-gauge stainless steel case encloses the cavity, the steam generating reservoir and the control compartment that houses electrical components. Door hinges are field-reversible (the door may be set to open from the left or right). Operating controls are on the front panel.

The SSB-3E/5E/10E steamers are equipped with fully electronic controls. These units are readily identified by their unique control panels. Steamer function is controlled by touch pad controls and a rotary timer-dial.

The drain system on all models includes a spray condenser, which cools drain water.



## Inspection and Unpacking

Your Groen SmartSteam100 Boilerless Steamer will be delivered completely assembled in a heavy shipping carton strapped to a skid. On receipt, inspect carton carefully for exterior damage.

**CAUTION**  
**SHIPPING STRAPS ARE UNDER TENSION AND CAN SNAP BACK WHEN CUT.**

Carefully cut the straps and detach the sides of the carton from the skid. Pull the carton up off the unit. Be careful to avoid personal injury or equipment damage from staples which might be left in the carton walls.

Write down the model number, serial number and installation date. Keep this information for reference. Space for these entries is provided at the top of the Service Log in the back of this manual.

SSB Steamer	Weight (LBS)	Weight (KGS)
SSB-3E Table Top	220	100
SSB-3E W/Stand	310	141
(2) SSB-3E W/Stand	500	227
SSB-5E Table Top	275	125
SSB-5E W/Stand	350	159
(2)SSB-5E W/Stand	555	252
SSB-10E W/Stand	469	213
(2)SSB-10E W/Stand	764	347

When starting installation, check packing materials to make sure loose parts such as the condensate drip tray are not discarded with this material.

# Installation and Startup

## WARNING

THE UNIT MUST BE INSTALLED BY PERSONNEL WHO ARE QUALIFIED TO WORK WITH ELECTRICITY AND PLUMBING. IMPROPER INSTALLATION CAN CAUSE INJURY TO PERSONNEL AND/OR DAMAGE TO THE EQUIPMENT. THE UNIT MUST BE INSTALLED IN ACCORDANCE WITH APPLICABLE CODES.

## CAUTION

DO NOT INSTALL THE UNIT WITH THE REAR VENTS BLOCKED OR WITHIN 2 INCHES OF A HEAT SOURCE SUCH AS A BRAISING PAN, DEEP FAT FRYER, CHARBROILER OR KETTLE.

TO AVOID DRAINAGE PROBLEMS, LEVEL THE UNIT FRONT TO BACK, AND PITCH SLIGHTLY TO THE FRONT.

## 1. Installation

Minimum Clearances: SmartSteam100 Boilerless Steamer requires the following minimum clearances to any surface, combustible or non-combustible.

<b>Right Side</b>	<b>2 inches</b>
<b>Left Side</b>	<b>2 inches</b>
<b>Rear</b>	<b>6 inches</b>

Steam Free Zone: The SmartSteam100 Boilerless Steamer can be damaged by steam from external sources. **Do not install** the steamer over a steam venting drain. Ensure that steam is not present in an area bounded by the footprint of the steamer and a circle 18 inches in radius about the right rear corner of the steamer (see figure below).

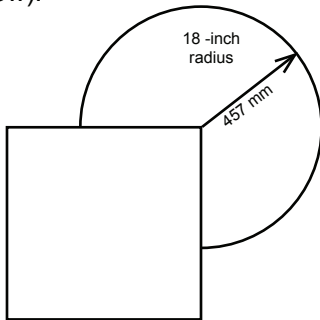

## 2. Electrical Supply Connection

### A. Panel Removal - Right Side

Open the wiring and control panel by removing screws from the right side panel. Slide the panel forward and set it aside.

### B. Supply Voltage

The unit must be operated at the rated name plate voltage. The name plate can be found on the rear of the unit.

### C. Phase Selection

Refer to steamer wiring diagram and element wiring on pages 19 and 20 for wiring information.

## CAUTION

**EACH UNIT MUST HAVE A SEPARATE GROUND WIRE FOR SAFE OPERATION.**

### D. Terminal Block

The terminal block for incoming power is located at the back of the control compartment. The ground terminal is located in the wiring compartment near the terminal block.

### E. Supply Wire

The equipment grounding wire must comply with the National Electrical Code (NEC) requirements. The wiring diagram on the inside of the unit's right side cover gives directions for proper connection of the terminal block jumpers. The wire must be used or the unit will not meet Underwriters Laboratories and NEC requirements. The electric hole is sized for a one-inch conduit fitting.

### F. Branch Circuit Protection

Each SmartSteam100 Boilerless Steamer, including individual units of stacked models, should have its own branch circuit protection and ground wire.



**WARNING**  
**TO AVOID DAMAGE OR PERSONAL INJURY,**  
**FOLLOW THE WIRING DIAGRAM EXACTLY**

Current and power demands for each unit are as shown below.

**ELECTRICAL SUPPLY CONNECTIONS**

SSB Steamer (KW RATING)	RATED CURRENT DEMAND PER CAVITY				
	208 3P	208 1P	240 3P	240 1P	480 3P
SSB-3E (9)	25	44	22	38	11
SSB-5E (12)	34	58	29	50	15
SSB-10E (21)	59	NA	51	NA	26

**3. Water Connection(s)**

Install a check valve to prevent back flow in the incoming cold water line, as required by local plumbing codes. Water pressure in the line should be between 30 - 60 PSI. If pressure is above 60 PSI, a pressure regulator will be needed. These pressures must provide the **1.5 gallons per minute** required for proper steamer function.

A 3/4 inch female NH connector (garden hose type) is used to attach the water supply to the inlet valve. **Minimum inside diameter of the water feed line is 1/2 inch.** Use a washer in the hose connection. Do not allow the connection to leak, no matter how slowly. Do not over-tighten hose connections.

This equipment is to be installed to comply with the basic plumbing code of the Building Officials and Code Administrators International, Inc. (BOCA) and the Food Service Sanitation Manual of the Food and Drug Administration (FDA).

**4. Drain Connection**

Level the steamer front to back, and pitch it slightly to the front (maximum 1/4 inch) by adjusting the optional legs or the bullet feet on the optional stand.

SSB-Steamer	Drain ID Hose Size Required (IN)
SSB-3E	1.5"
(2)SSB-3E	2.5"
SSB-5E	1.5"
(2)SSB-5E	2.5"
SSB-10E	2.0"
(2)SSB-10E	2.5"

**WARNING:**  
**DO NOT CONNECT THE DRAIN DIRECTLY TO A BUILDING DRAIN. BLOCKING THE DRAIN IS HAZARDOUS.**

There must be a free air gap between the end of the hose and the building drain. The free air gap should be as close as possible to the unit drain. There must also be no other elbows or other restrictions between the unit drain and the free air gap.

**CAUTION**  
**DO NOT USE PLASTIC PIPE. DRAIN MUST BE RATED FOR BOILING WATER.**

Install the drain line with a constant downward pitch. **IMPORTANT: Do not allow water traps in the line. A trap can cause pressure build-up in the cavity, which may cause the door gasket to leak.**



**IMPROPER DRAIN LINE CONNECTION**

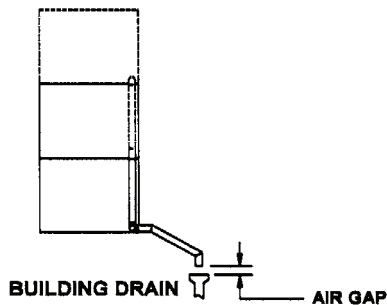

**Proper Drain Line Connection – Drain Line must have a constant downward pitch of at least 1/4" per foot. Observe local code regarding air gap spacing and drain connections.**

**5. Factory-Stacked Units**

This section is applicable only if you are installing factory-stacked units.

Installing stacked steamers is similar to installing a single unit. The steamers are stacked and assembled at the factory and delivered with the water connections and drain hoses required for a single point connection.

**A. Water Connection**

The same water supply connection is used for both units. At the water inlet valve a 3/4 inch female NH connector (garden hose type) is used for the water supply.

**B. Electrical Supply Connection**

Separate electrical connections will be required for each steamer to be stacked. Each steamer unit must have its own branch circuit protection.

**C. Drain Connection**

Steamers must be leveled front to back, and pitched to the rear (maximum 1/4 inch) by adjusting the bullet feet on the cabinet or stand base.

For all factory-stacked SSB steamers, a 2 1/2 inch ID hose is attached to the unit drain. It must be rated for boiling water.

**6. Counter-Mounted Units**

This section is applicable if the steamer will be mounted to a counter. All four edges of the bottom of the steamer must be sealed with RTV to the counter if the 4 inch legs are not used. Counter must be made of a noncombustible material such as metal or tile.

**WARNING:  
DO NOT STACK SSB STEAMERS WHEN LEGS ARE USED.**

## Initial Startup

After the SmartSteam100 Boilerless Steamer has been installed, test it to ensure that the unit is operating correctly.



1. Remove all literature and packing materials from the interior and exterior of the unit.
2. Make sure the water supply line is open.
3. Turn on electrical service to the unit. The steamer will not operate without electrical power. Do not attempt to operate the unit during a power failure.  
**NOTE:** The door **MUST** be closed for the elements to operate.
4. To turn unit on, press the ON switch on the control panel.
5. When the steam generating reservoir has filled with water, the heaters will begin heating automatically. Within 20 minutes or less the READY light will come on, indicating that the water has reached its standby temperature. When the READY light is displayed, you may take any one of the following steps:
  - a. Push TIMED and set the timer knob to the desired steaming time.
  - b. Push MANUAL for continuous steaming.
  - c. Push STOP to let the unit stay at ready condition.
6. To shut down the unit, press the OFF switch. The steam generating reservoir will then fill with cold water and drain.
7. If the steamer operates as described, the unit is functioning correctly and ready for use.

**WARNING**  
**WHEN YOU OPEN THE DOOR, STAY AWAY**  
**FROM STEAM COMING OUT OF THE UNIT.**  
**STEAM CAN CAUSE BURNS.**

# Operation

## A. Controls

Operator controls are on the front right of the unit.

The control panels have the following touch pads and indicator lights:

- The TIME display shows the remaining cooking time. It displays three dashes in MANUAL mode.
- The ON/OFF rocker switch gets the SmartSteam100 ready for use or shuts it off.
- The READY indicator light indicates the unit has achieved the ready temperature.
- Hour meter records cumulative hours of operation.
- The FAULT display shows the current fault.

### The push button operations:

1. In the STOP mode the steam generator stays at a low boil or ready temperature.
2. When the TIMED button is pushed, the TIMED light will illuminate and time can be set by turning the TIMER knob (cook time can be increased or decreased at any time by turning the timer knob). The unit steams until the timer counts down to zero and the temperature drops to ready. At that time the STOP light illuminates and a beeper sounds.
3. When the MANUAL button is pushed, the unit steams continuously. The MANUAL light will stay illuminated.
4. CANCEL button should be pushed to stop beeping.

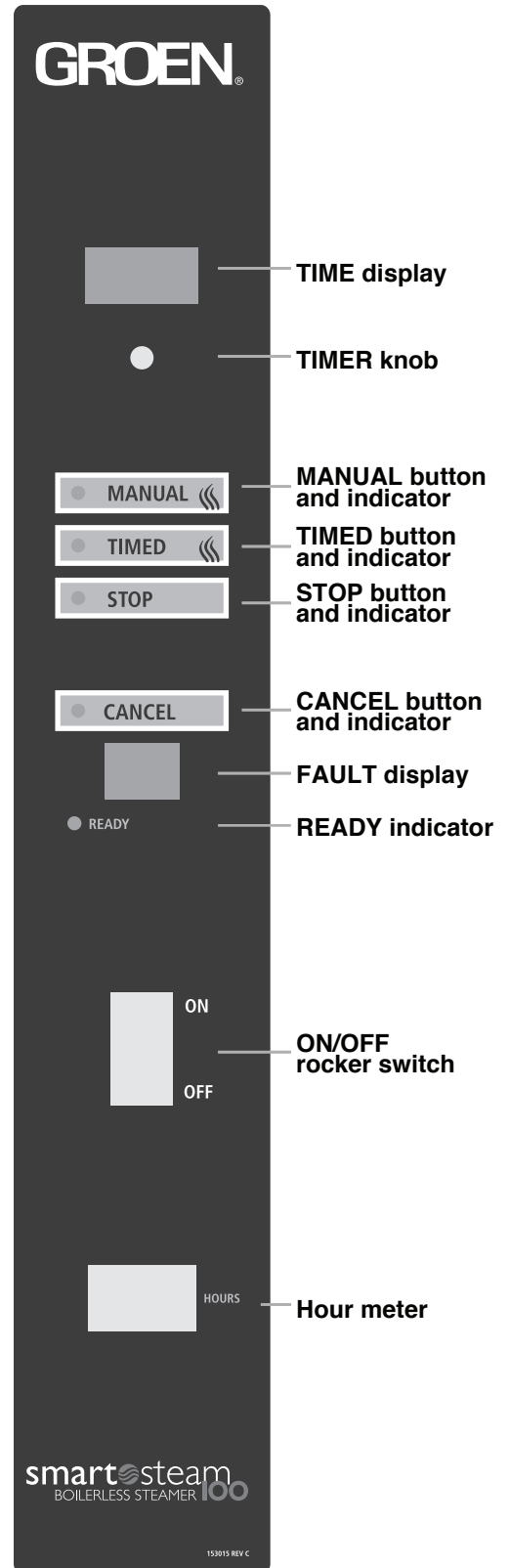

## B. Operating Procedure

1. Press the ON/OFF rocker to the ON position, (Fi\_) is displayed in the TIME display window. The steam generating reservoir will begin filling, displaying (Fi\_) and (Fi\_) as it fills. After initial fill the unit will begin draining displaying (Fi\_), refilling displaying (Fi\_), and then begin heating until the READY light comes on (about 15-20 minutes).

2. Load food into pans in uniform layers. Pans should be filled to about the same levels, and should not be mounded.
3. Open the door and slide the pans into the supports. If you will only be steaming one pan, put it in the middle position. Some foods will cause foam. When cooking foods that foam, such as shrimp, put an empty solid 2½" deep pan in the bottom slot of the pan racks.
4. Close the door. When the READY indicator is lit take one of the following steps:

If you want to steam the food for a certain length of time push the TIMED button and set the desired time with the TIMER knob. The timer will automatically run the steamer for the set time and then STOP. A beeper will sound. Push CANCEL to stop beeping.

If you want to steam continuously push the MANUAL button. The unit will continue steaming until stopped.

Push STOP to stop producing steam.

5. To remove pans from cavity open the door. Remove the pans from the steamer using hot pads or oven mitts to protect your hands from the hot pans.



**WARNING**  
**WHEN YOU OPEN THE DOOR, STAY AWAY FROM THE STEAM COMING OUT OF THE UNIT. THE STEAM CAN CAUSE BURNS.**

6. To shut off the unit press the ON/OFF rocker switch to OFF, (FL\_) will appear in the timer display. The steam generating reservoir will begin draining, displaying (Fi\_) and (Fi\_) as it drains, and refill to the high float twice and finally drain completely and turn off the unit.

NOTE: When filling or draining the steam generating reservoir (≡) will be displayed indicating the water level in the reservoir. ( ) reservoir is empty, ( ) low float is satisfied, (≡) high float is satisfied.

NOTE: If a large amount of shrimp is cooked in the SmartSteam100 foaming will occur because the steam lid actually gets so hot that the shrimp will cook on its surface and the shrimp proteins in the dripping will foam on the surface of the steam lid.

\* To avoid this use a catch pan to catch shrimp drippings and proteins to prevent foaming when cooking a large amount of shrimp.

———— High Float  
———— Low Float  
———— Empty

## Cleaning

To keep your SmartSteam100 Boilerless Steamer in proper working condition, use the following procedure to clean the unit. This regular cleaning will reduce the effort required to clean the steam generator and cavity.

### A. Suggested Supplies

1. Mild detergent
2. Stainless steel exterior cleaner Groen Spray DeGreaser (Part Number 140830WS)
3. Cloth or sponge
4. Brush with soft bristles
5. Spray bottle
6. Measuring cup
7. Nylon pad
8. Towels
9. Plastic disposable gloves
10. Funnel



### B. Procedure

1. Exterior Cleaning
  - a. Prepare a warm solution of the mild detergent as instructed by the supplier. Wet a cloth with this solution and wring it out. Use the moist cloth to clean the outside of the unit. Do not allow freely running liquid to touch the controls, the control panel, any electrical part, or any louver on the rear panels.
  - b. To remove material which may be stuck to the unit, use a fiber brush or a plastic or rubber scraper with a detergent solution.
  - c. Stainless steel surfaces may be polished with a recognized stainless steel cleaner.
2. Interior Cleaning



Daily cleaning must be done in order to enhance the performance and prolong the life of your SmartSteam Boilerless Steamer.

**WARNING**  
**DISCONNECT THE POWER SUPPLY BEFORE CLEANING THE OUTSIDE OF THE STEAMER.**

**KEEP WATER AND CLEANING SOLUTIONS OUT OF CONTROLS AND ELECTRICAL COMPONENTS. NEVER HOSE OR STEAM CLEAN ANY PART OF THE UNIT.**

**AVOID CONTACT WITH ANY CLEANERS, DELIMING AGENT OR DEGREASER AS RECOMMENDED BY THE SUPPLIER. MANY ARE HARMFUL. READ THE WARNINGS AND FOLLOW THE DIRECTIONS!**

**EVEN WHEN THE UNIT HAS BEEN SHUT OFF, DON'T PUT HANDS OR TOOLS INTO THE COOKING CHAMBER UNTIL THE FAN HAS STOPPED TURNING.**

**DON'T OPERATE THE UNIT UNLESS THE REMOVABLE PARTITION HAS BEEN PUT BACK IN ITS PROPER LOCATION.**

**DON'T USE ANY CLEANING AGENT THAT CONTAINS ANY SULFAMIC AGENT OR ANY CHLORIDE, INCLUDING HYDROCHLORIC ACID (HCL). TO CHECK FOR CHLORIDE CONTENT SEE ANY MATERIAL SAFETY DATA SHEETS PROVIDED BY THE CLEANING AGENT MANUFACTURER.**

### IMPORTANT

**DO NOT USE ANY METAL MATERIAL (SUCH AS METAL SPONGES) OR METAL IMPLEMENTS (SUCH AS A SPOON, SCRAPER OR WIRE BRUSH) THAT MIGHT SCRATCH ANY STAINLESS STEEL SURFACE. SCRATCHES MAKE THE SURFACE HARD TO CLEAN AND PROVIDE PLACES FOR BACTERIA TO GROW. DO NOT USE STEEL WOOL, WHICH MAY LEAVE PARTICLES EMBEDDED IN THE SURFACE, WHICH COULD EVENTUALLY CAUSE CORROSION AND PITTING.**

**WARNING! ALLOW THE STEAMER TO COOL COMPLETELY BEFORE CLEANING. HOT SURFACES CAN CAUSE SEVERE BURNS.**

**CLEANING STEPS:**

**STEP 1** - Press OFF switch to turn steamer OFF and open steamer door.

**STEP 2** - CAUTION: allow the steamer to cool completely before cleaning.

**STEP 3** - Remove steam lid by grasping the two tabs located on the lid front and sliding pan forward.

**STEP 4** - Remove left pan rack by lifting rack up and pulling away from cavity wall.

**STEP 5** - Remove right fan shroud and rack assembly by lifting rack up and pulling away from cavity wall.

**STEP 6** - Clean steam lid, left pan rack and rack/shroud assembly to remove food soils. These three parts may be cleaned in a dishwasher.

**STEP 7** - Use a mild detergent to wipe down the entire steamer cavity to remove food and scale particles. Carefully clean float probes if food residue or loose scale is present. A thin layer of tightly bound scale is normal and will not affect steamer performance. If scale is excessive, then refer to deliming instructions below.

**STEP 8** - Remove drain strainer and clean thoroughly to remove any build-up of debris.

**STEP 9** - Replace pan racks and steam lid. Steamer is now cleaned and ready to use.

**FAILURE TO CLEAN THE STEAMER AS SPECIFIED COULD NEGATIVELY IMPACT THE PERFORMANCE OF THE STEAMER.**

FLOAT PROBE ORIENTATION

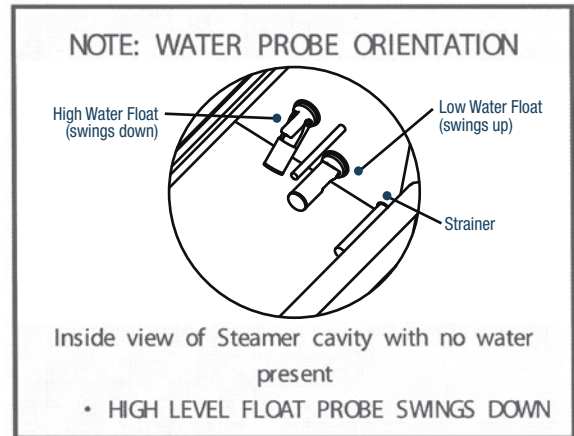

**DELIMING INSTRUCTIONS:**

- When using Groen Boilerless Water Filtration System use vinegar as a deliming agent.
- Groen approved delimer may be used to remove excessive scale build-up.

**STEP 1** - After following all cleaning steps 1 through 7 listed above, turn steamer on and allow water to enter steamer cavity.

**STEP 2** - Pour 1 cup of vinegar or delimer into steamer cavity and shut door.

**STEP 3** - Set steamer timer to 30 minutes and allow steam cleaning to occur.

**STEP 4** - After 30 minutes cleaning cycle is complete, turn steamer OFF and allow to cool completely.

**STEP 5** - Open steamer door and wipe down the entire steamer cavity to remove loosened scale particles. Carefully clean float probes if loose scale is present.

**STEP 6** - Replace pan racks and steam lid. Steamer is now cleaned and ready to use.

## Maintenance

The SmartSteam100 Boilerless Steamer is designed for minimum maintenance and no user adjustments should be necessary. Certain parts may need replacement after prolonged use. If there is a need for service, only Groen Authorized Service Agents should perform the work.

If steam or condensate is seen leaking from around the door, take the following steps:

1. Check the door gasket. Replace it if it is cracked or split.
2. Inspect the cooking chamber drain to be sure it is not blocked.
3. Adjust the door latch pin to allow for changes that might occur as the gasket ages.
  - a. Loosen the lock nut at the base of the latch pin, then turn the latch pin  $\frac{1}{4}$  turn clockwise, and tighten the lock nut.
  - b. After adjustment, run the unit to test for further steam leakage.
  - c. If there is still leakage, repeat the adjustment
  - d. Continue adjusting the pin clockwise until the door fits tightly enough to prevent leakage. The hinge may also be adjusted.

## Troubleshooting

Your Groen SmartSteam100 Boilerless Steamer is designed to operate smoothly and efficiently if properly maintained. However, the following is a list of checks to make in the event of a problem. Wiring diagrams are furnished inside the service panel. If an item on the check list is marked with (\*), it means that the work should be done by a Groen Authorized Service Agent.

SYMPTOM	WHO	WHAT TO CHECK
1. Fault Display 1 or 2	User	a. Clean floats in unit / Check float probe orientation b. Be sure water supply is adequate to run steamer(s) during normal operation.
2. No power.	User	a. Check wall circuit breaker. b. Disconnect power, then check fuses inside steamer. * c. Call service technician.
3. Unit overfills with water at start up.	User	a. Clean floats in unit / Check float probe orientation. b. Clean drain strainer. c. Call service technician.
4. Steamer does not fill with water.	User	a. Is the ON switch depressed? b. Is the water supply connected? c. Is the water turned on? d. Is the water supply hose kinked or obstructed? e. Check for low water pressure (less than 30 PSI) or low water flow (less than 1.5 gpm). f. Is the screen at the water connection clogged?
5. "Door" Shown in Time Display Window	User	a. Is the steamer door securely closed?
6. No steam.	User	a. Is the ON switch depressed? b. Is the water supply connected? c. Is the water turned on? d. Is steamer door completely closed?
7. Fault Display 7	User	a. The component cooling fan may not be operating. The display may come on for several minutes during normal operation. If it stays on for more than 30 minutes, call service technician. Unit may be used for cooking, while waiting for service.

8. Any unusual operation.	User	a. Press OFF switch to turn steamer off. Momentarily turn circuit breaker off and then turn unit back on.
9. Door pops open.	User	a. Ensure drain and vent are not plugged. No more than two units should be attached to a single drain line. b. Check door pin adjustment per above. c. Call service technician.
10. Fault Display 6	User	a. Wait 30 minutes for unit to cool down. b. Call service technician.

PARTS LIST – SSB-3E/5E/10EF

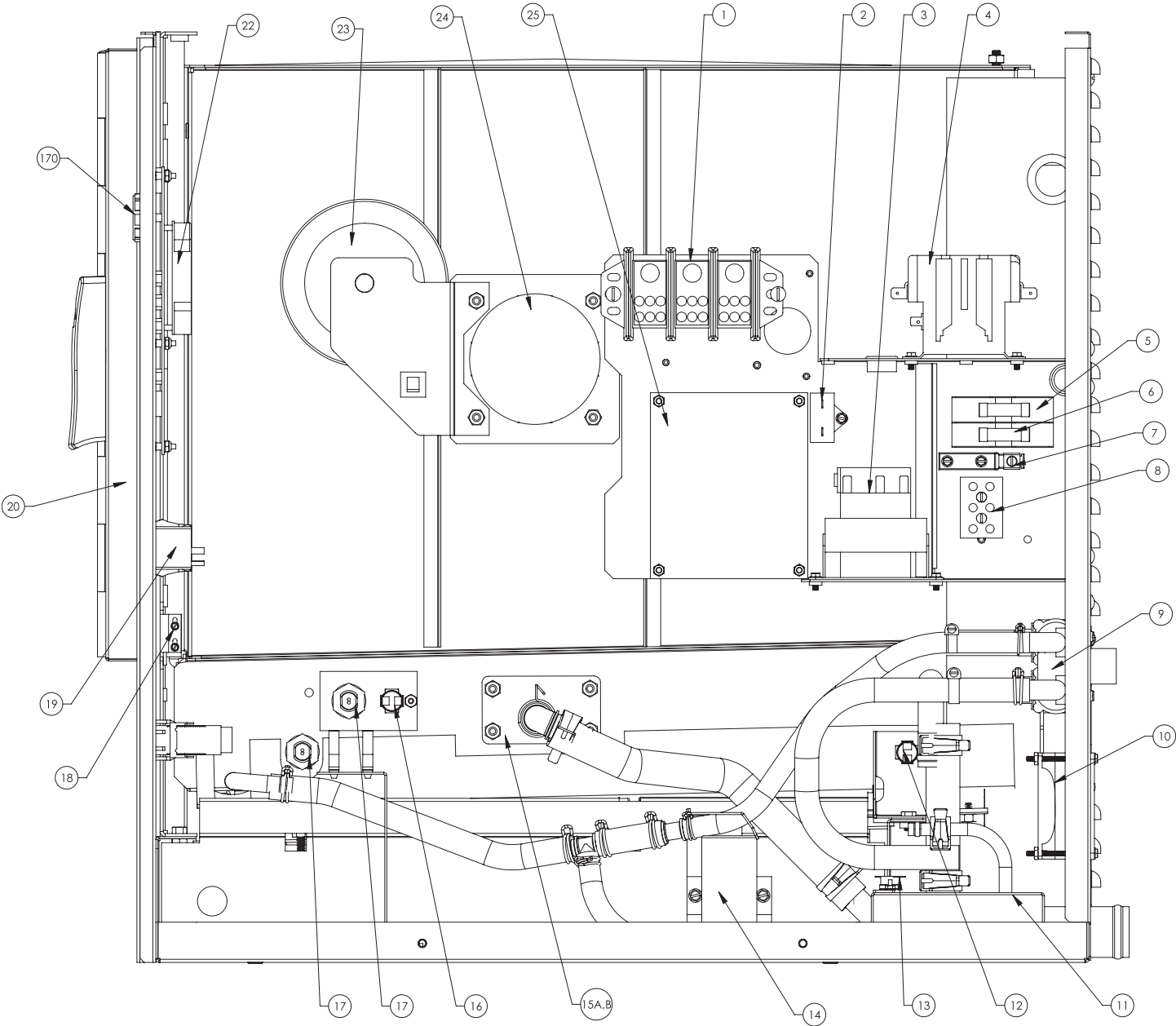

PARTS LIST – SSB-3E/5E/10EF

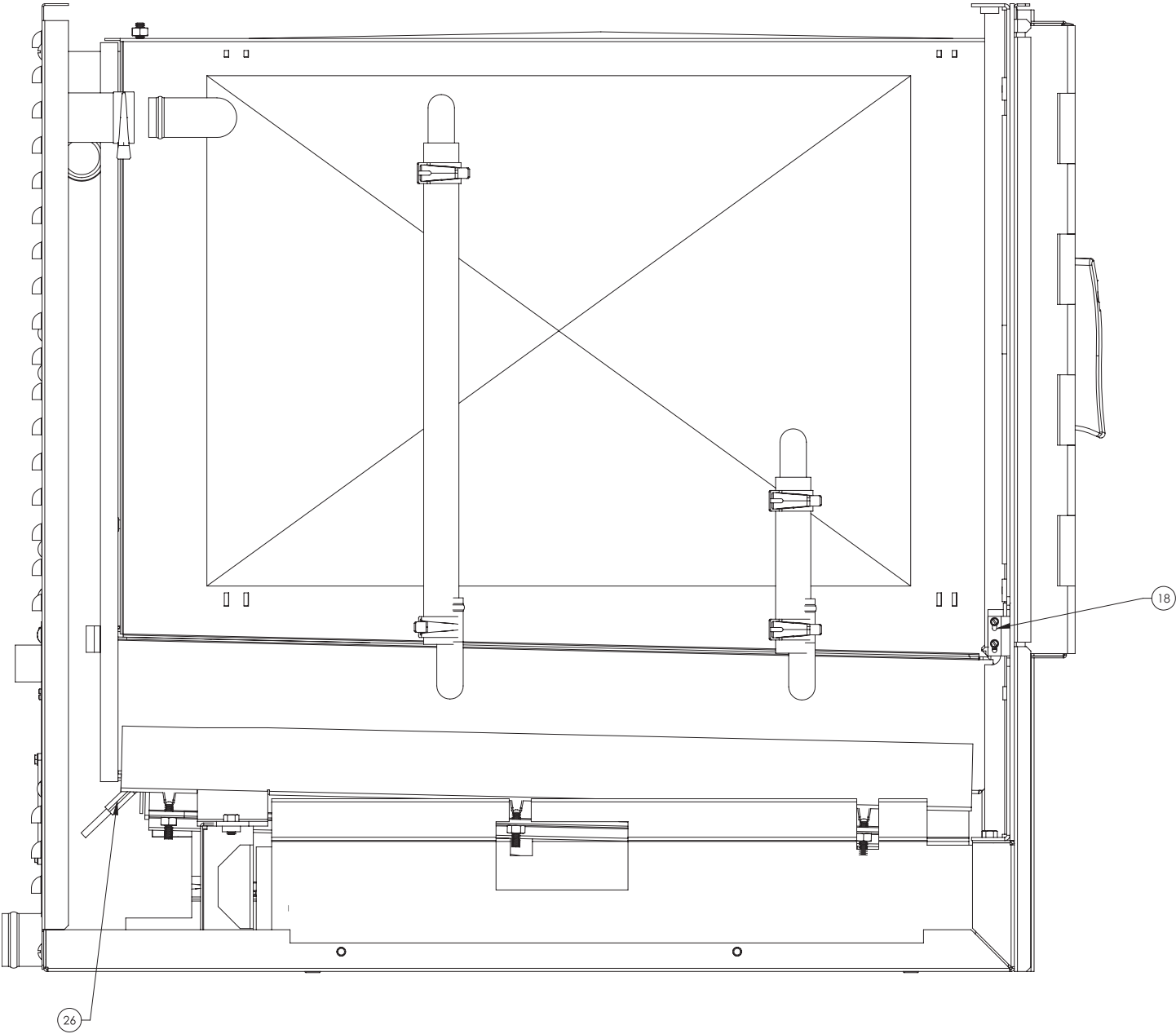

PARTS LIST – SSB-3E/5E/10EF

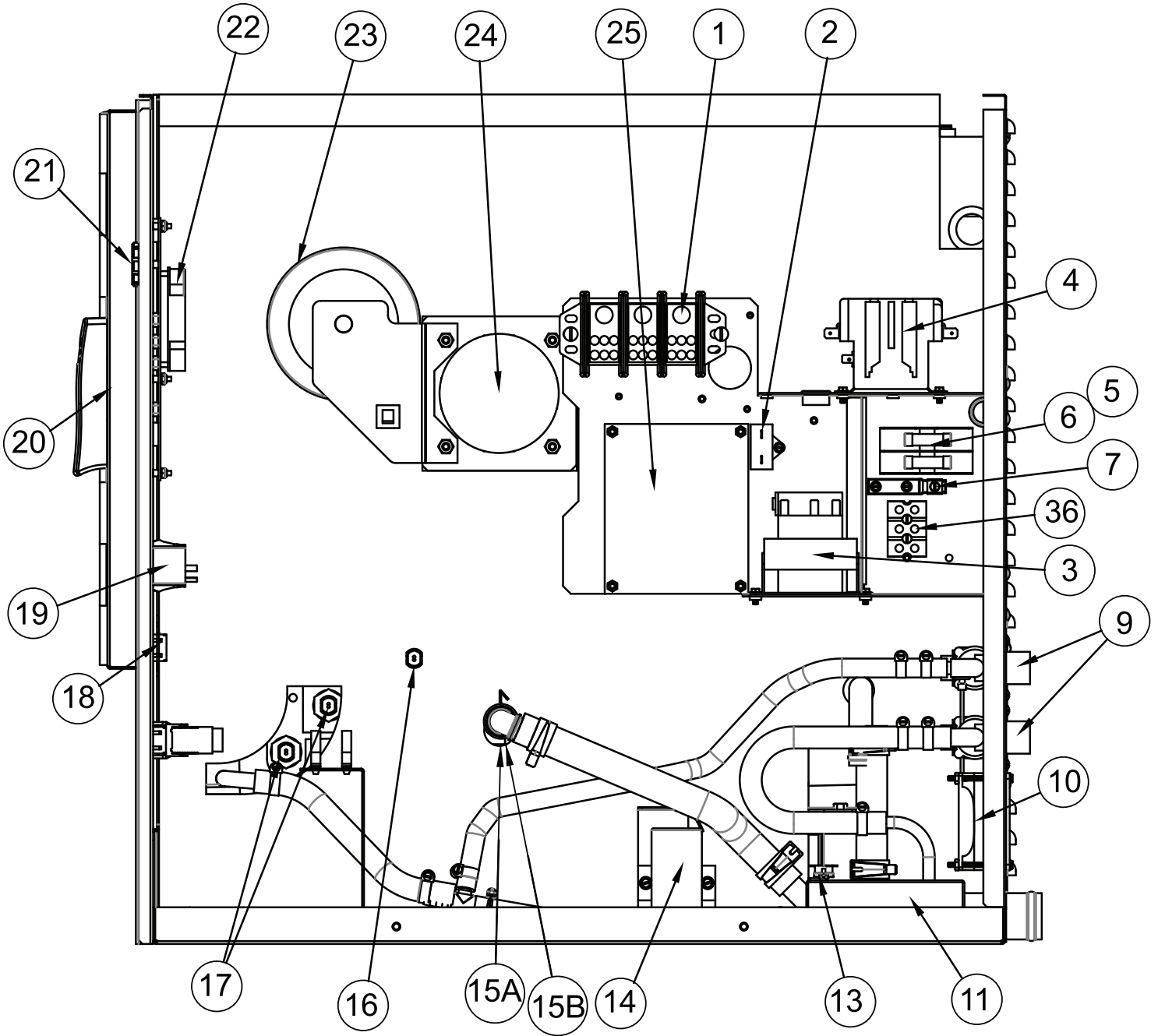

PARTS LIST – SSB-3E/5E/10EF

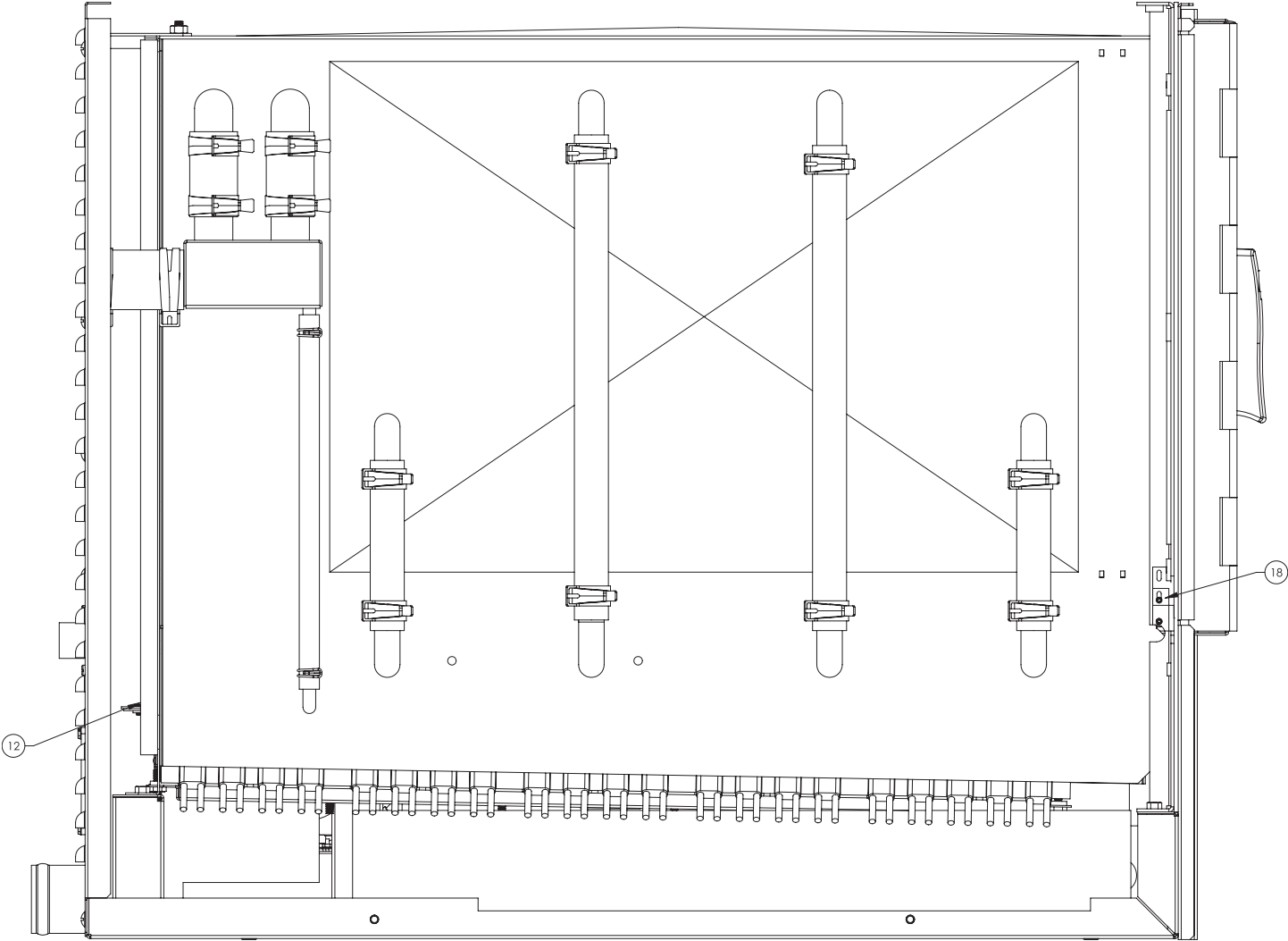

PARTS LIST – SSB-3E/5E/10EF



## PARTS LIST – SSB-3E/5E/10EF

To order parts, contact your Groen Authorized Service Agent. Supply the model designation, serial number, part description, part number, quantity, and when applicable, voltage and phase.

Key	Description	Part No.	Key	Description	Part No.
1	Terminal Block	070185	28	Front Panel Overlay (3E)	153015
2	Capacitor, 3MF	096813		Front Panel Overlay (5E/10E)	153472
3	Transformer 208/240v Primary/ 24v secondary, 75VA	121716	29	Door Latch Pin	078914
4	Contactator	145081	30	Door Pin Lock Nut	003823
5	Fuseholder	096809	31	Steam Lid (3E/5E)	149299
6	Fuse	119823		Steam Lid (10E)	149452
7	Ground Terminal (3E/5E)	106412	32	Cavity Fan	096790
	Ground Terminal (10E)	129714	33	Left Pan Rack (3E)	149883
8	Terminal Block (3E/5E)	003888		Left Pan Rack (5E)	149872
	Terminal Block (10E)	002577		Left Pan Rack (10E)	145642
9	Water Valve -- PRE-2015 --	071235	34	Door Handle	129723
9	Water Valve -- 2016 --	100934	35	Door Gasket (3E)	124849
10	Muffin Fan	153505		Door Gasket (5E)	125907
11	Drain Box (3E/5E)	150659		Door Gasket (10E)	143879
	Drain Box (10E)	150661	36	Terminal Block 480v Only (10E)	003888
12	Hi-Limit	144484	x	Motor Shaft Seal	096868
13	Thermostat (drain box)	145248	x	Blower Cover (3E)	149387
14	Drain Valve	071234		Blower Cover (5E)	149313
15A	Condensate Cup	150628		Blower Cover (10E)	149451
15B	Gasket, condensate cup	142613	x	Right Pan Rack (3E)	141571
16	Ready Thermostat	147285		Right Pan Rack (5E)	140157
17	Water Level Probe (Serial Number MSA and MSB)	142689		Right Pan Rack (10E)	145721
	Float Probe (Serial Number MSC and Following)	149880	x	Drip Tray (3E/5E)	094151
18	Door Switch	096857		Drip Tray (10E)	145520
19	Power Switch	160920	x	Left Side Panel (3E)	149229
20	Door Assembly, Complete (3G)	130858		Left Side Panel (5E)	149233
	Door Assembly, Complete (5G)	125922		Left Side Panel (10E)	149446
	Door Assembly, Complete (10G)	143874	x	Right Side Panel (3E)	149231
21	Knob	160921		Right Side Panel (5E)	149235
22	Control Board	160648		Right Side Panel (10E)	149448
23	Tooroid (480V only)	119833	x	Flow Reducer, Condensate	147371
24	Motor Assembly	146880	x	Flow Reducer, Fill	144481
25	Relay Board	160649	x	Harness, Control To Relay Board SSB	160884
26	Element 208v 1000w (3E/5E)	148553	x	Harness, SSB Rear (3E/5E)	160883
	Element 240v 1000w (3E/5E)	148554	x	Harness, SSB Low Voltage (3E/5E)	160880
	Element 277v 1000w (3E/5E)	148552	x	Harness, SSB Foward (3E/5E)	160882
	Element 208v 1000w (10E)	148444	x	Harness, Steamer High Voltage (3E/5E)	160874
	Element 240v 1000w (10E)	148551	x	Harness, SSB High Voltage	153486
	Element 277v 1000w (10E)	148443	x	Jumper, Voltage Select	123124
27	Top Panel (3E/5E)	150637	x	Harness, SSB-10E Low Voltage	153841
	Top Panel (10E)	149444	x	Harness, SSB-10E Forward	153842
			x	Harness, SSB-10E Rear	153843
			x	Harness, Steamer 480v only	153118

x- Item not depicted/called out in drawing or photograph

# WIRING DIAGRAM – SSB-3E/5E/10EF

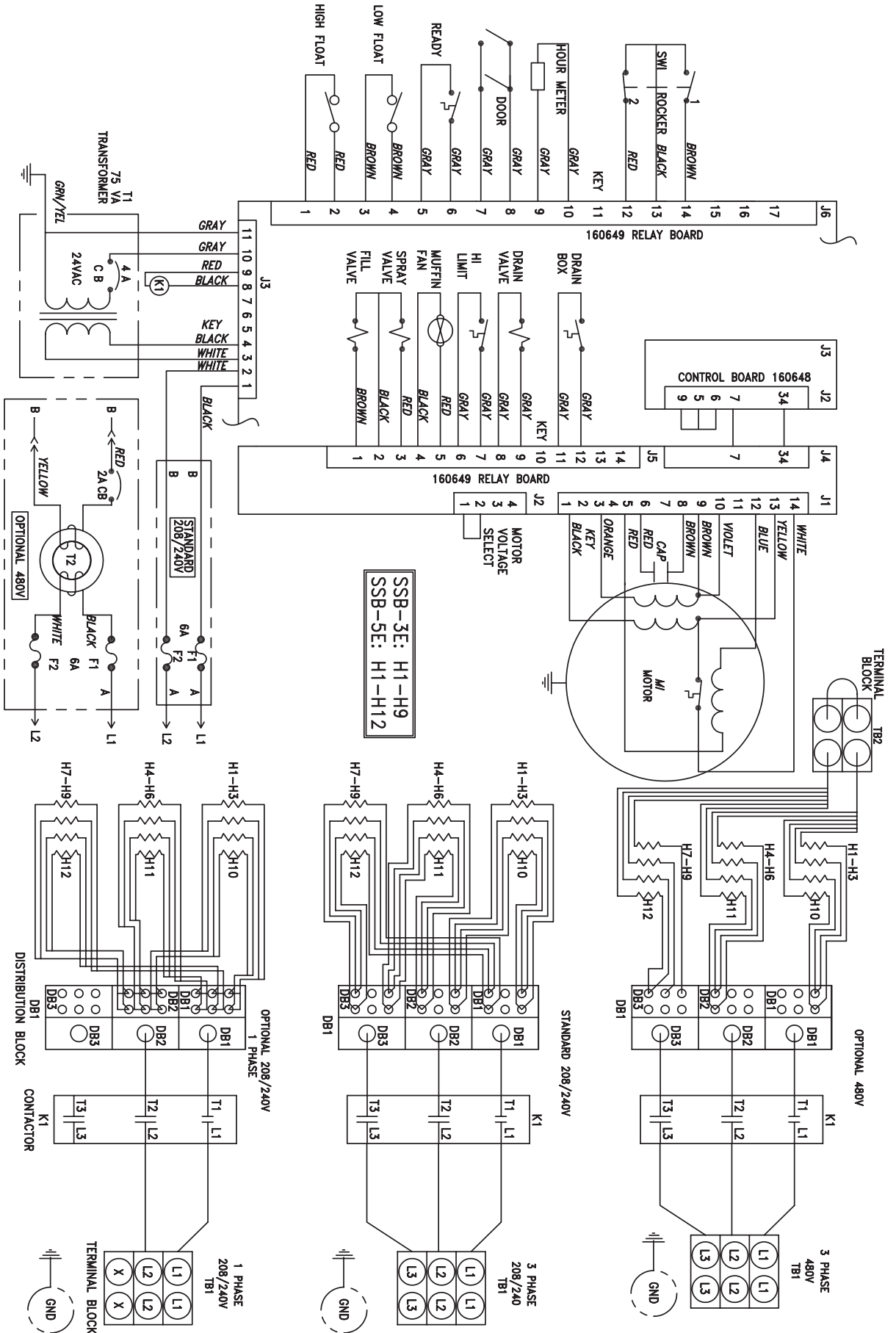

153333 REV. B SSB-3E/5E WIRING DIAGRAM



# WIRING DIAGRAM – SSB-3E/5E/10EF

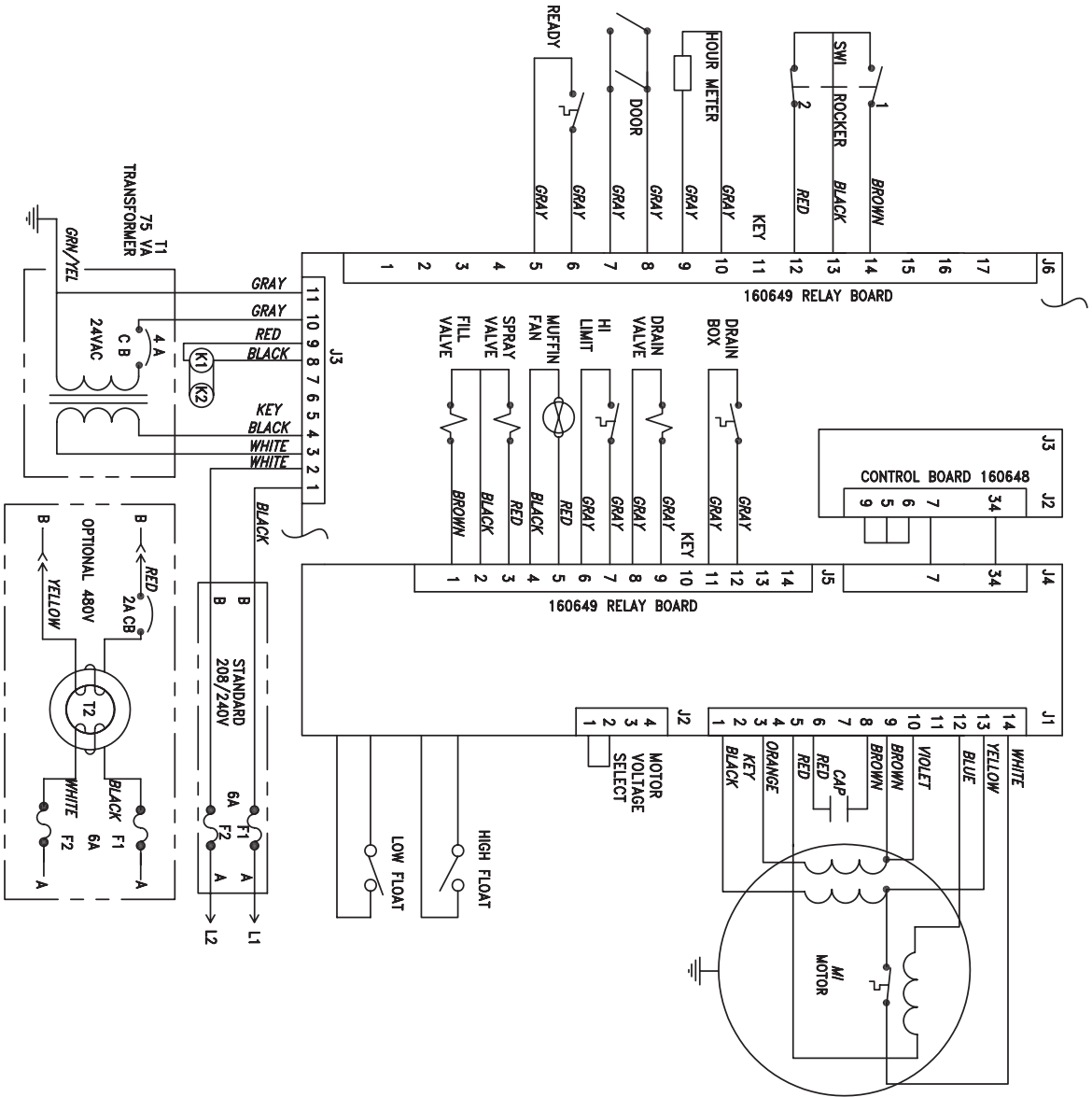

160469 SSB-10E WIRING DIAGRAM

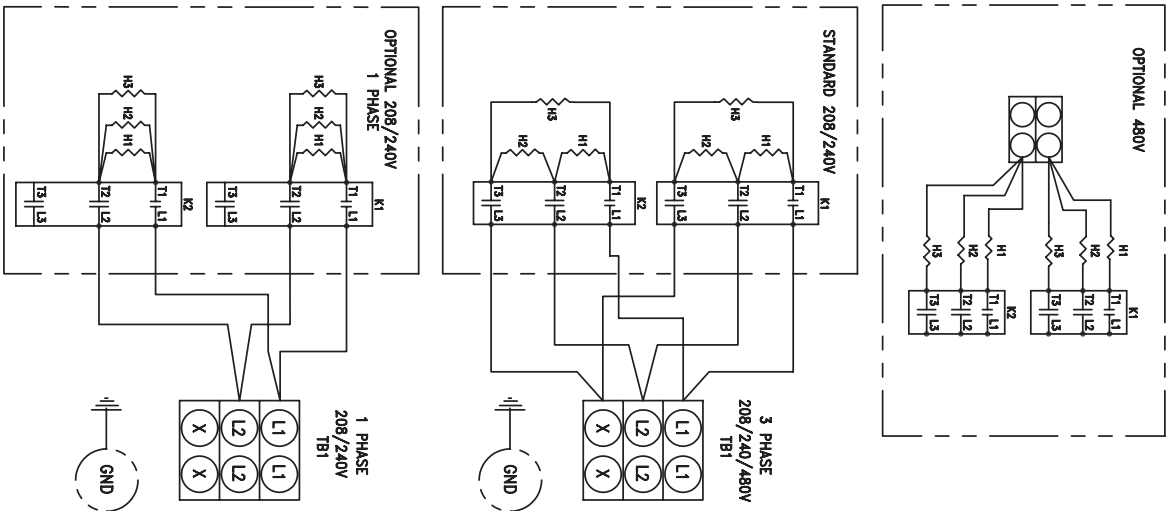



## **GROEN LIMITED WARRANTY TO COMMERCIAL PURCHASE\* (U.S. & Canadian Sales Only)**

Groen warrants to original commercial purchaser/users that foodservice equipment manufactured by Groen ("Groen Equipment") other than CapKold foodservice equipment, shall be free from defects in material and workmanship for (i) 2000 actual operating hours (provided that such equipment has a device that has recorded actual operating hours since the installation of such equipment), (ii) twelve (12) months from the date of installation or (iii) fifteen (15) months from the date of shipment from Groen, whichever first occurs (the "Warranty Period"), in accordance with the following terms and conditions:

**I.** This warranty is limited to replacement parts and related labor for Groen Equipment located at its original place of installation in the United States and Canada.

**II.** Damage to Groen Equipment that occurs during shipment must be reported to the carrier and is not covered under this warranty. The reporting of any damage during shipment is the sole responsibility of the commercial purchaser/user of such Groen Equipment.

**III.** For Groen Convection Combo™ Steamer-Ovens, HyPerSteam™ Convection Steamers and HyPlus™ Pressureless Steamers, Groen further warrants to the original commercial purchaser/users of such Groen Equipment that the atmospheric steam generators or boilers contained in such Groen Equipment shall be free from defects in material and workmanship for (i) 4000 actual operating hours (provided that such equipment has a device that has recorded actual operating hours since the installation of such equipment), (ii) twenty-four (24) months from the date of installation or (iii) twenty-seven (27) months from date of shipment from Groen, whichever first occurs, provided that: (a) the original purchaser/user shall have also purchased and installed a Groen PureSteam™ Water Treatment System for use in connection with such Groen Convection Combo Steamer-Oven, HyPerSteam Convection Steamer or HyPlus Pressureless Steamer on or before the date such Groen Equipment was installed, (b) the original purchaser/user has continuously used such Water Treatment System in connection with such Groen Equipment from the date of installation, and (c) the commercial purchaser/user shall have maintained such Water Treatment System in accordance with the maintenance and filter cartridge replacement recommendations of Groen, and otherwise maintained such Oven or Steamer in accordance with all other operational and maintenance recommendations of Groen.

**IV.** For Groen SmartSteam100™ Boilerless Steamers and Vortex100™ Connectionless Steamers, Groen further warrants to the original commercial purchaser/users of SmartSteam™ Boilerless Steamers and Vortex™ Connectionless Steamers shall be free from defects in material and workmanship for (i) 4000 actual operating hours (provided that such equipment has a device that has recorded actual operating hours since the installation of such equipment), (ii) twenty-four (24) months from the date of installation or (iii) twenty-seven (27) months from the date of shipment from Groen, whichever first occurs. This warrants Groen Vortex100 Connectionless Steamers that were shipped after March 15, 2004, and SmartSteam100 Boilerless Steamers that were shipped after May 1, 2003.

**V.** Groen further warrants to the original commercial purchaser/users of Groen Convection Combo Steamer-Ovens that the electronic relay and control board contained in such Groen Convection Combo Steamer-Oven shall be free from defects in material and workmanship for (i) 4000 actual operating hours (provided that such equipment has a device that has recorded actual operating hours since the installation of such equipment), (ii) twenty-four (24) months from the date of installation or (iii) twenty-seven (27) months from the date of shipment from Groen, whichever first occurs.

**VI.** During the Warranty Period, Groen, directly or through its authorized service representative, will either repair or replace, at Groen's sole election, any Groen Equipment determined by Groen to have a defect in material or workmanship. As to any such warranty service during the Warranty Period, Groen will be responsible for related reasonable labor and portal to portal transportation expenses (time & mileage) incurred within the United States and Canada.

**VII.** This warranty does not cover boiler maintenance, calibration, periodic adjustments as specified in operating instructions or manuals, consumable parts (such as scraper blades, gaskets, packing, etc.), and labor costs incurred for removal of adjacent equipment or objects to gain access to Groen Equipment. This warranty does not cover defects caused by improper installation, abuse, careless operation, or improper maintenance of Groen Equipment. This warranty does not cover damage to Groen Equipment caused by poor water quality or improper boiler maintenance.

**VIII.** THIS WARRANTY IS EXCLUSIVE AND IS IN LIEU OF ALL OTHER WARRANTIES, EXPRESSED OR IMPLIED, INCLUDING ANY IMPLIED WARRANTY OF MERCHANTABILITY OR FITNESS FOR A PARTICULAR PURPOSE, EACH OF WHICH IS HEREBY EXPRESSLY DISCLAIMED. THE REMEDIES DESCRIBED ABOVE ARE EXCLUSIVE AND IN NO EVENT SHALL GROEN BE LIABLE FOR SPECIAL, CONSEQUENTIAL, OR INCIDENTAL DAMAGES FOR THE BREACH OR DELAY IN PERFORMANCE OF THIS WARRANTY.

**IX.** Groen Equipment is for commercial use only. If sold as a component of another (O.E.M.) manufacturer's equipment, or if used as a consumer product, such Equipment is sold AS IS and without any warranty.

**Cost of Extended Coverage.**

Limited Extended Warranty Coverage is available on all standard Groen Equipment (other than CapKold foodservice equipment) covered by the above Groen Limited Warranty. Commercial purchasers/users of Groen Equipment may elect to extend the standard limited warranty to cover parts, labor and portal to portal transportation costs (time and mileage) for an additional (i) 2000 actual operating hours, or (ii) twelve (12) month period, or for an additional (i) 4000 actual operating hours, or (ii) twenty four (24) month period, whichever first occurs, in addition to the time period of the standard limited warranty described above. Limited Extended Warranty Coverage is not available to extend the supplemental limited warranty for: (a) atmospheric steam generators or boilers contained in Groen Convection Combo Steamer-Ovens, HyPerSteam Convection Steamers and HyPlus Pressureless Steamers, or (b) electronic relay and control boards contained in Groen Convection Combo Steamer-Ovens, or (c) Groen SmartSteam100 Boilerless Steamers, or (d) Vortex100 Connectionless Steamers

Five percent (5.0%) of the LIST PRICE of the Groen Equipment to be covered by the Limited Extended Warranty for each additional twelve (12) months of limited extended warranty coverage. The five percent (5.0%) of the LIST PRICE charge will be the net invoice amount for each year of Limited Extended Warranty Coverage purchased.

**Conditions of Coverage**

**(1)** Limited Extended Warranty Coverage must be purchased at the time the Groen Equipment to be covered is purchased.

**(2)** All conditions and limitations on the Standard Limited Warranty Coverage apply to the Limited Extended Warranty Coverage. See above for details of conditions and limitations on the Standard Warranty Coverage.

Covers Groen Equipment (other than CapKold foodservice equipment and Vortex Connectionless Steamers) ordered after September 11, 2001.

## NOTES:

## NOTES:



**1055 Mendell Davis Drive • Jackson MS 39272**  
**888-994-7636 • 601-372-3903 • Fax 888-864-7636**  
**[unifiedbrands.net](http://unifiedbrands.net)**