

# WORKTOP REFRIGERATOR

## Model: SW48N

Natural Refrigerant R-290 Model

### 48" Worktop Refrigerator with Solid Doors



ENERGY STAR® Qualified Commercial Refrigerator

Stainless steel front, top and end panels, aluminum back and interior.



## Options and Accessories

(upcharge and lead times may apply)

Stainless steel interior	Stainless steel shelves
Stainless steel back	Door locks
Drawers in lieu of doors (consult factory)**	Special electrical requirements (consult factory)
Additional epoxy coated steel shelves	Expansion valve system
Overshelves (single or double)	Adjustable Legs

Consult factory for other model configurations, options and accessories.

\*\*Two tier: (1) 12 x 18 x 6 pan per drawer or (1) 1/2 size x 6 & (1) 1/3 x 6 pans per drawer

Project Name:

Model Specified:

Location:

Item No:

Quantity:

AIA #:

SIS #:

## Standard Model Features

### REFRIGERATION SYSTEM

Performance rated refrigeration system

Natural, environmentally safe, high efficiency R-290 refrigerant<sup>1</sup>

Automatic, hot gas condensate evaporator

Non-corrosive, plasticized fin evaporator coil

Easily serviceable, back mounted compressor

### CABINET ARCHITECTURE

2" non-CFC polyurethane foam insulation

Smooth, polished chrome door handles

Spring loaded, self closing doors

Magnetic snap in Santoprene™ door gaskets

Heavy duty, epoxy coated steel shelves

Completely enclosed, vented and removable case back

5" casters

### MODEL FEATURES

Field rehingeable doors

Electronic controller with digital display & hi/low alarm

Off-cycle defrost

<sup>1</sup> R-290 refrigerant meets all federal and state regulatory requirements.

**Continental**  
Refrigerator

Toll-Free: 800-523-7138  
Phone: 215-244-1400  
Fax: 215-244-9579

539 Dunksferry Road  
Bensalem, PA 19020  
www.continentalrefrigerator.com

APPROVAL:

## Model Specifications

### DIMENSIONAL DATA

Net Capacity (cubic feet)	13.4 (379 cu l)
Width, Overall (inches)	48 (1219 mm)
Depth, Overall (inches) (including handles & bumpers)	32 $\frac{3}{16}$ (818 mm)
Height, Overall (inches) (including 5" casters)	35 $\frac{1}{4}$ (895 mm)
Shelf Area (square feet)	6.8 (0.6 sq m)
Number of Shelves	2
Number of Doors	2
Interior Depth (inches)	See Drawing
Interior Height (inches)	26 $\frac{1}{4}$ (667 mm)
Interior Width (inches)	44 (1118 mm)

### REFRIGERANT DATA

Condensing Unit Size (H.P.)	$\frac{1}{5}$
Capacity (BTU per hour)*	1625

\* Rating @ +25°F evaporator, 90°F ambient

### ELECTRICAL DATA

Voltage (International)	115/60/1 (220/50/1)
Total Amps (International)	2.5 (2.2)
10 ft. Cord/Plug [attached] (International)	Yes (No)

### SHIPPING DATA

Weight (pounds)	248 (112 kg)
Height - Crated (inches)	43 $\frac{1}{4}$ (1099 mm)
Width - Crated (inches)	56 (1422 mm)
Depth - Crated (inches)	37 $\frac{1}{4}$ (946 mm)

Figures in parentheses reflect metric equivalents rounded to the nearest whole unit.



Equipped with one NEMA-5-15P Plug  
(varies by country)

## Model Plan Views

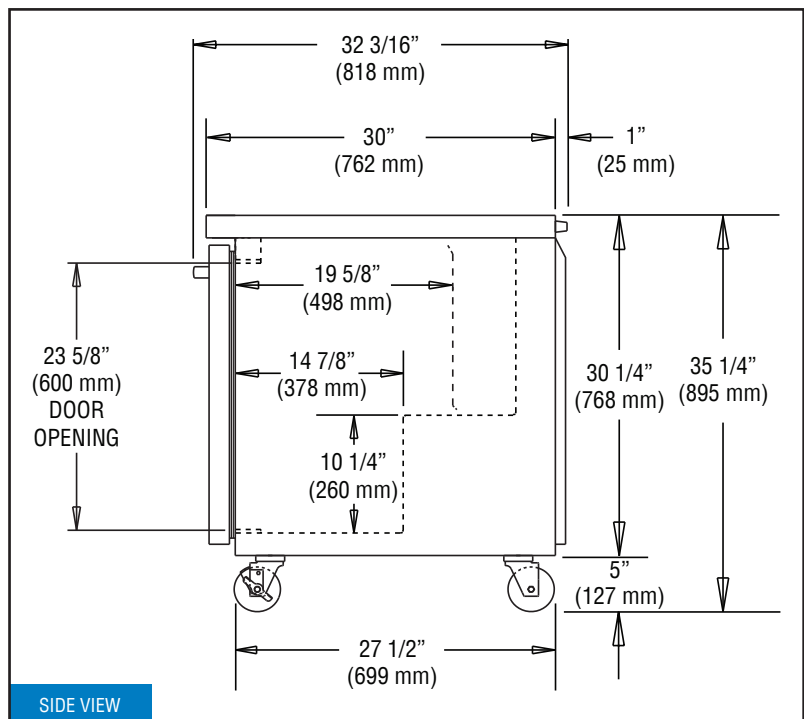
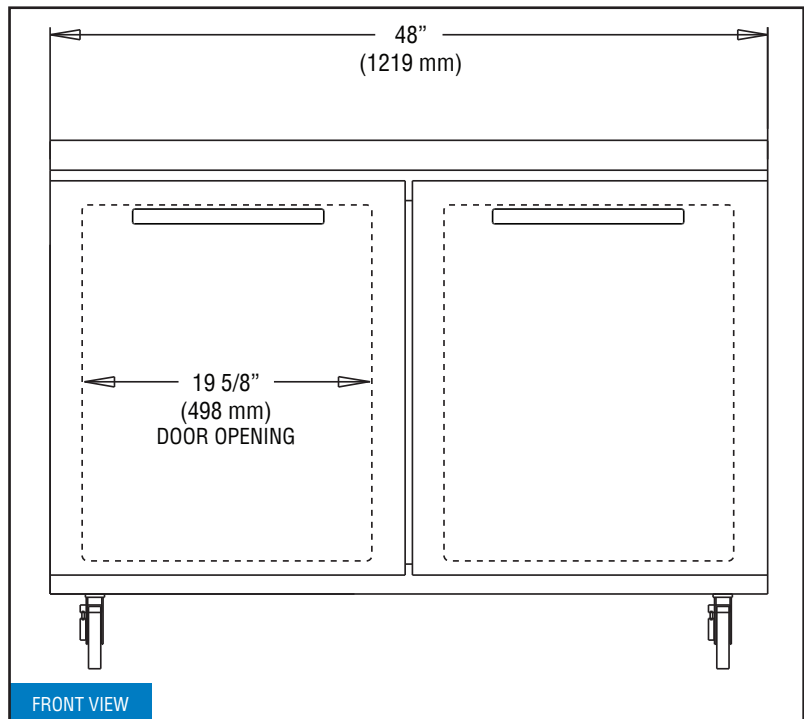

**IMPORTANT NOTE:** If the cabinet is located directly against a wall, a minimum clearance of 3" is required on sides, front and rear.

**Continental**  
Refrigerator

Toll-Free: 800-523-7138  
Phone: 215-244-1400  
Fax: 215-244-9579

539 Dunksferry Road  
Bensalem, PA 19020  
[www.continentalrefrigerator.com](http://www.continentalrefrigerator.com)

Due to our continued efforts in developing innovative products, specifications subject to change without notice.



© Copyright 2021. Continental Refrigerator.  
A Division of National Refrigeration & Air Conditioning Products, Inc.

REVISED: 5/16/2022