



PROJECT: _____

ITEM # _____ QTY: _____

MODEL # _____

AIA # _____ SIS # _____

UNDERCOUNTER PEARL ICE MAKER

UNDERCOUNTER PEARL ICE MAKER

GEMU09090



Features and Benefits

- Fan favorite soft, chewable Pearl nugget-style ice.
- Cools beverages faster and longer while maintaining flavors better.
- Produces 110 lbs of ice per 24 hours in a compact, undercounter platform.
- Premium stainless exterior.
- Saves on power and water.
- Field reversible door with concealed door hinge.
- Sealed top bearing increases reliability and durability.
- Uses R290 for more environmentally friendly and energy efficient refrigerant.



| ICE FORMS | |
|-----------|---------------|
| PEARL ICE | 1/2 x 3/8 in. |
| | 12.7 x 9.5 mm |

Warranty

- Ice Maker: 1 Year Parts and Labor - Residential or Commercial

Options & Accessories

- KPMP - Pump Kit for GEMU09090

Water Filter

- IFI4C or IFI8C Inline Filter System

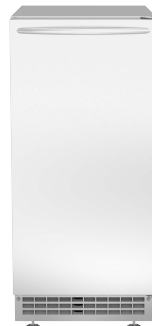

| STORAGE CAPACITY | |
|------------------|-------------------|
| Capacity | 26 lbs (12 kg) |
| Width | 14.96 in (380 mm) |



Ice-O-Matic

UNDERCOUNTER PEARL ICE MAKER

GEMU09090

Line drawing note: Numbers with quote symbol " are in inches. Numbers enclosed in [brackets] are in millimeters.

PLAN / TOP VIEW

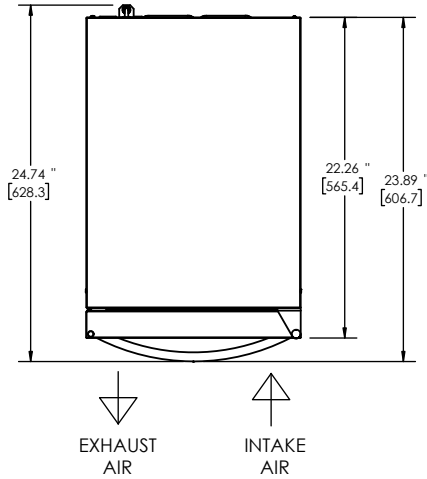

ELEVATION / FRONT VIEW

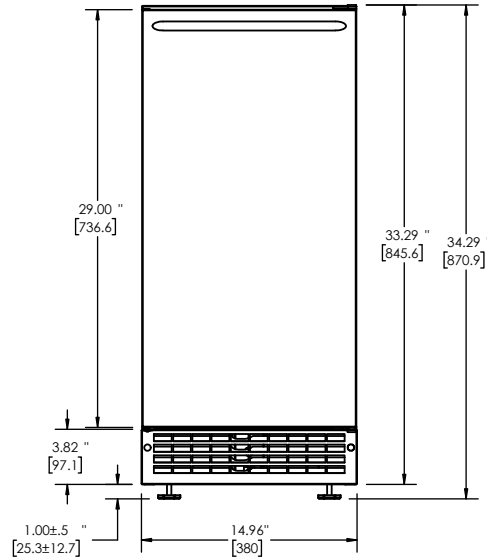

UTILITIES / BACK VIEW

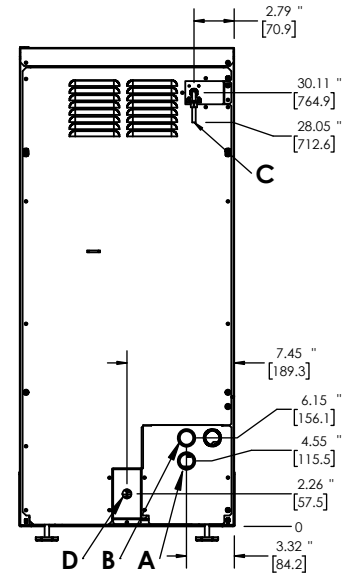

Air Cooled

- A. Ice Maker Drain Access - Gravity, 5/8" ID Flexible Tubing
- B. Ice Maker Drain Access - Pump (Optional), 5/8" ID Flexible Tubing
- C. Ice Maker Potable Water Inlet, 1/4" Copper Tube With Compression Fitting
- D. Electrical Connection, Power Cord

| SPECIFICATIONS | |
|---|------------------------------|
| Model | GEMU09090 |
| Condensing Type | Air |
| Voltage/Hertz/Phase | 115/60/1 |
| Min. Circuit Amp | N/A |
| Max Breaker Size | 15 A |
| KWH per 100 lbs of ice at 70°F air / 50°F water | 4.2 |
| KWH per 100 lbs of ice at 90°F air / 70°F water | 6.4 |
| BTU (approx per hour) | 1500 |
| Number of Wires | Standard Plug included |
| Refrigerant | R290A |
| Refrigeration Charge | 85 g |
| Ice Production per 24 hrs | |
| 70° air / 50° water lbs (kg) | 90° air / 70° water lbs (kg) |
| 110 (50) | 72 (33) |
| Water Usage gallons per 100 lbs of ice 90°F air / 70°F water | |
| Potable | Condenser |
| 12 | N/A |

| OPERATING REQUIREMENTS | | |
|-------------------------|-------------------|-------------------|
| | MINIMUM | MAXIMUM |
| Ambient Temp. Range Air | 50°F (10°C) | 100°F (38°C) |
| Water Temp | 40°F (4°C) | 100°F (38°C) |
| Water Pressure | 20 PSIG (1.4 BAR) | 80 PSIG (5.5 BAR) |

| DIMENSIONS | | |
|---------------------------|-----------------------------------|--------|
| Unit Width | 15 in. | 378 mm |
| Unit Depth | 24 in. | 600 mm |
| Unit Height | 34 in. | 848 mm |
| Shipping Weight | 114 lbs / 52 kg | |
| Shipping Dimensions (in.) | 27(W) x 17(D) x 36 (H) | |
| Shipping Dimensions (mm) | 685.8 (W) x 431.8 (D) x 914.4 (H) | |

