



PROJECT: \_\_\_\_\_  
 ITEM # \_\_\_\_\_ QTY: \_\_\_\_\_  
 MODEL # \_\_\_\_\_  
 AIA # \_\_\_\_\_ SIS # \_\_\_\_\_

PEARL ICE MAKER

# PEARL ICE MAKER

## GEM1306A90



### Features and Benefits

- Uses R290 for a more environmentally friendly and efficient refrigerant.
- Modular design and dual exhaust for flexible application and easy installation on bins or dispensers.
- Easy to clean with front facing evaporator and dishwasher safe (up to 180°F) components.
- Easy and quick cleaning reduces operating costs.
- Simple service with many common parts across all CIM machines.
- Harvest Assist provides consistent ice production for the life of the ice maker while reducing energy consumption and increasing capacity.
- Durable, electroless nickel plating on all evaporator plates ensures reliability.
- Constructed from corrosion-resistant and fingerprint-proof aluminum.



ICE FORMS	
PEARL ICE	1/2 x 3/8 in.
	12.7 x 9.5 mm



BIN CHART									
Model #	B40	B42	B55	B700-30	B110	B1000-48	B1300-48	B1325-60	B1660-60
capacity	344 lbs (156 kg)	351 lbs (160 kg)	510 lbs (232 kg)	680 lbs (308 kg)	854 lbs (388 kg)	1,000 lbs (454 kg)	1,320 lbs (599 kg)	1,325 lbs (601 kg)	1,660 lbs (753 kg)
width	30 in (762 mm)	22 in (559 mm)	30 in (762 mm)	30 in (762 mm)	48 in (1,219 mm)	48 in (1,219 mm)	48 in (1,219 mm)	60 in (1,524 mm)	60 in (1,524 mm)
Kit for combining wider bins with smaller models	KBT19	KBT24	KBT19	Kit Not Required	KBT23	Kit Not Required	Kit Not Required	Kit Not Required	Kit Not Required

See Ice-O-Matic Price List for Adapter Kits to combine ice makers with most available ice/beverage dispensers.



GEM1306A90 shown atop of bin B42 (sold separately)

### Warranty

- Ice Maker: **3 Years Parts and Labor**
- Compressor: **5 Years Parts**

### Options & Accessories

- KGEMDISPB for ice level control for a dispenser - verify adaptor with disp. manufacturer

### Water Filter

- Manifold System IFQ2 gets replacement filter IOMQ (2)

11100 E. 45th Avenue • Denver, CO 80239

Phone: 1.866.PURE.ICE

www.iceomatic.com

Rev. 04/2026 Printed in U.S.A.

APPROVAL: \_\_\_\_\_ DATE: \_\_\_\_\_



Ice-O-Matic

# PEARL ICE MAKER

## GEM1306A90

Line drawing note: Numbers with quote symbol " are in inches. Numbers enclosed in [brackets] are in millimeters.

PLAN / TOP VIEW

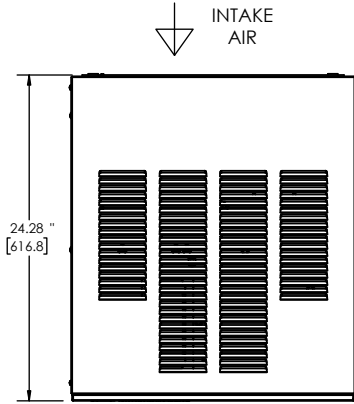

Ice Drop Zone Shown w/o Louvers

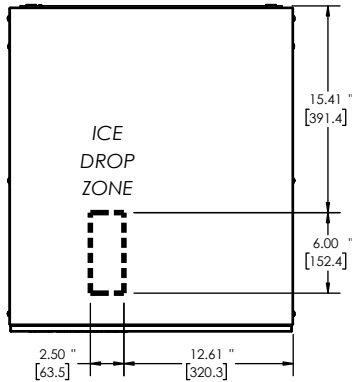

ELEVATION / FRONT VIEW

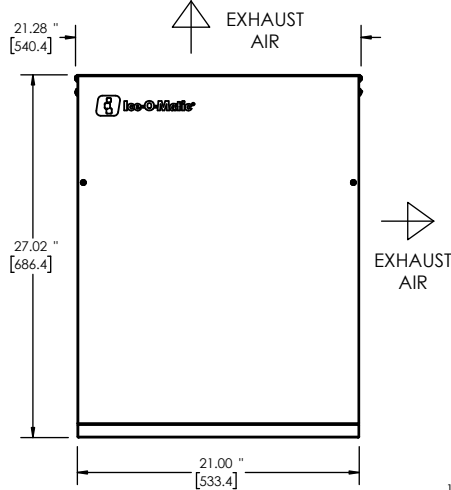

UTILITIES / BACK VIEW

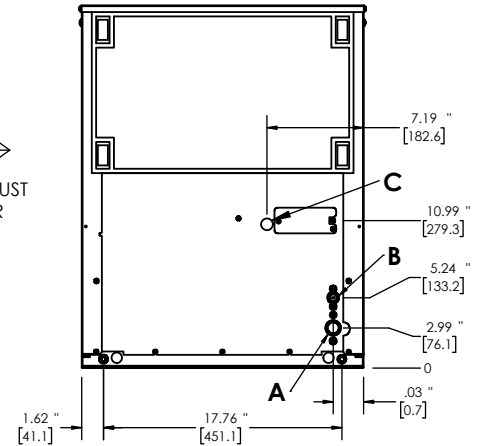

Air Cooled

- A. Ice Maker Drain, 3/4" FPT
- B. Ice Maker Potable Water Inlet, 3/8" FPT
- C. Electrical Connection,  $\Phi$ .875" [22.2]

SPECIFICATIONS	
Model	GEM1306A90
Condensing Type	Air
Voltage/Hertz/Phase	208-230/60/1
Min. Circuit Amp	13.5 A
Max Breaker Size	20 A
kWH per 100 lbs of ice at 70°F air / 50°F water	2.4
kWH per 100 lbs of ice at 90°F air / 70°F water	3.40
BTU (approx per hour)	15840
Number of Wires	3 (including ground)
Refrigerant	R290A
Refrigeration Charge	150 g
<b>Ice Production per 24 hrs</b>	
70° air / 50° water lbs (kg)	90° air / 70° water lbs (kg)
1306 (592)	1004 (455)
<b>Water Usage gallons per 100 lbs of ice 90°F air / 70°F water</b>	
Potable	Condenser
12	N/A

OPERATING REQUIREMENTS		
	MINIMUM	MAXIMUM
Ambient Temp. Range Air	50°F (10°C)	100°F (38°C)
Water Temp	40°F (4°C)	100°F (38°C)
Water Pressure	20 PSIG (1.4 BAR)	80 PSIG (5.5 BAR)

DIMENSIONS		
Unit Width	21 in.	533 mm
Unit Depth	24 in.	610 mm
Unit Height	27 in.	686 mm
Shipping Weight	219 lbs / 99 kg	
Shipping Dimensions (in.)	27 (W) x 24 (D) x 32 (H)	
Shipping Dimensions (mm)	685.8 (W) x 609.6 (D) x 812.8 (H)	

