



PROJECT: _____
 ITEM # _____ QTY: _____
 MODEL # _____
 AIA # _____ SIS # _____

CUBE ICE MAKER

CUBE ICE MAKER

CIM0330HA90



Features and Benefits

- Uses R290 for a more environmentally friendly and efficient refrigerant.
- Modular design and dual exhaust for flexible application and easy installation on bins or dispensers.
- Easy to clean with front facing evaporator and dishwasher safe (up to 180°F) components.
- Easy and quick cleaning reduces operating costs.
- Simple service with many common parts across all CIM machines.
- Harvest Assist provides consistent ice production for the life of the ice maker while reducing energy consumption and increasing capacity.
- Durable, electroless nickel plating on all evaporator plates ensures reliability.
- Constructed from corrosion-resistant and fingerprint-proof aluminum.

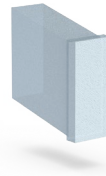

ICE FORMS	
HALF CUBE	3/8 x 7/8 x 7/8 in.
	10 x 22 x 22 mm



BIN CHART									
Model #	B40	B42	B55	B700-30	B110	B1000-48	B1300-48	B1325-60	B1660-60
capacity	344 lbs (156 kg) 30 in (762 mm)	351 lbs (160 kg) 22 in (559 mm)	510 lbs (232 kg) 30 in (762 mm)	680 lbs (308 kg) 30 in (762 mm)	854 lbs (388 kg) 48 in (1,219 mm)	1,000 lbs (454 kg) 48 in (1,219 mm)	1,320 lbs (599 kg) 48 in (1,219 mm)	1,325 lbs (601 kg) 60 in (1,524 mm)	1,660 lbs (753 kg) 60 in (1,524 mm)
Kit for combining wider bins with smaller models	Kit Not Required	Not Compatible	Kit Not Required	Kit Not Required	BPF-1	Kit Not Required	Kit Not Required	Kit Not Required	Kit Not Required

See Ice-O-Matic Price List for Adapter Kits to combine ice makers with most available ice/beverage dispensers.



CIM0330HA90 shown atop of bin B55 (sold separately)

Warranty

- Ice Maker: **3 Years Parts and Labor**
- Evaporator and Compressor: **5 Years Parts**
- Evaporator: **7 Years Parts and Labor**
(if enrolled in the filter program for US & Canada)

Options & Accessories

- KSI-1 - Safe Ice Module
- KCUBEDISPB for mounting to a dispenser
- B55

Water Filter

- Manifold System IFQ1 gets replacement filter IOMQ (1)

11100 E. 45th Avenue • Denver, CO 80239

Phone: 1.866.PURE.ICE

www.iceomatic.com

Rev. 04/2026 Printed in U.S.A.

APPROVAL: _____ DATE: _____



Ice-O-Matic

CUBE ICE MAKER

CIM0330HA90

Line drawing note: Numbers with quote symbol " are in inches. Numbers enclosed in [brackets] are in millimeters.

PLAN / TOP VIEW

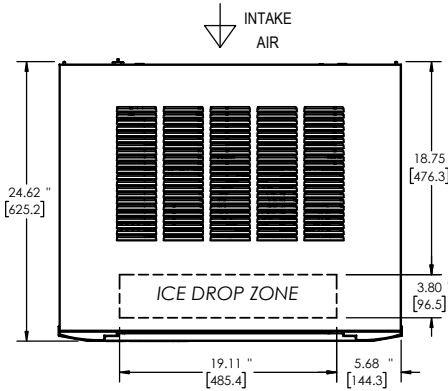

ELEVATION / FRONT VIEW

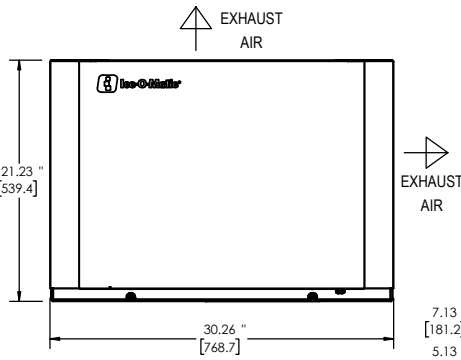

UTILITIES / BACK VIEW

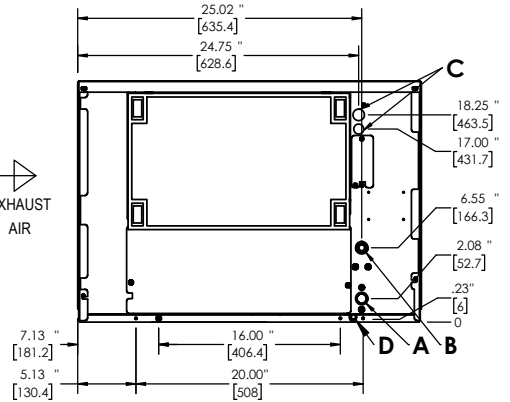

Air Cooled

- A. Ice Maker Drain, 3/4" FPT
- B. Ice Maker Potable Water Inlet, 3/8" FPT
- C. Electrical Connection, Φ .875" [22.2] (2)
- D. Condensate Base Drain, Φ .50" [12.7]

SPECIFICATIONS	
Model	CIM0330HA90
Condensing Type	Air
Voltage/Hertz/Phase	115/60/1
Min. Circuit Amp	11.4 A
Max Breaker Size	15 A
kWH per 100 lbs of ice at 70°F air / 50°F water	3.90
kWH per 100 lbs of ice at 90°F air / 70°F water	6.40
BTU (approx per hour)	5650
Number of Wires	3 (including ground)
Refrigerant	R290A
Refrigeration Charge	140 g
Ice Production per 24 hrs	
70° air / 50° water lbs (kg)	90° air / 70° water lbs (kg)
325 (147)	240 (109)
Water Usage gallons per 100 lbs of ice 90°F air / 70°F water	
Potable	Condenser
19.0	N/A

OPERATING REQUIREMENTS		
	MINIMUM	MAXIMUM
Ambient Temp. Range Air	50°F (10°C)	100°F (38°C)
Water Temp	40°F (4°C)	100°F (38°C)
Water Pressure	20 PSIG (1.4 BAR)	80 PSIG (5.5 BAR)

DIMENSIONS		
Unit Width	30.25 in.	768 mm
Unit Depth	24.25 in.	616 mm
Unit Height	21.25 in.	540 mm
Shipping Weight	142 lbs / 64 kg	
Shipping Dimensions (in.)	33 (W) x 27 (D) x 27 (H)	
Shipping Dimensions (mm)	838.2 (W) x 685.8 (D) x 685.8 (H)	



B55

Features

- Application storage capacity from 242 lbs (110 kg) to 854 lbs (388 kg).
- Multiple bin tops provide an easy solution for mounting ice makers on different sized bins.
- Polyethylene bin liner is insulated with foam for maximum ice preservation – 1.5" to 3" (38 mm to 76 mm).
- 31" deep for use where space is at a premium.
- Built-in ice scoop holders on certain models.
- Sturdy leg design – 6" (152 mm) adjustable NSF approved legs – standard.
- Durable aluminum finish.

Bin Accessories

Ice-O-Matic Part Number	Description
1011517-22	Plastic ice shovel
1011517-23	Hanging bracket for ice shovel
1011517-24	46.5" Plastic paddle
1051517-29	Hanging bracket for ice paddle
9051127-01	82 Ounce ice scoop

Single Ice Machine Configurations

Ice-O-Matic offers a full line of bins for most applications. From low profile slope-front bins to high capacity space-saving uprights, we have a bin to meet any need. The following table will help you create the system you need in a safe and cost effective manner.

Bin Model No.	Style	Application Bin Storage lbs (kgs)	Approximate Shipping Weight lbs (kgs)	CIM Series Cube Makers	ICE Series Cube Makers			Nugget Ice Makers	Flake Ice Machine
				30" (762 mm) wide	22" (559 mm) wide	30" (762 mm) wide	48" (1,219 mm) wide	21" (533 mm) wide	21" (533 mm) wide
B25PP*	Slope Front	242 (110)	74 (34)	△△	KBT19	△△	N/A	KBT19	KBT19
B40PS	Slope Front	344 (156)	103 (47)	△△	KBT19	△△	N/A	KBT19	KBT19
B42PS	Slope Front	351 (160)	99 (45)	N/A	△△	N/A	N/A	KBT24	KBT24
B55PS	Slope Front	510 (232)	125 (57)	△△	KBT19	△△	N/A	KBT19	KBT19
B110PS	Slope Front	854 (388)	163 (74)	BPF-1***	N/A	BPF-1***	△△	KBT23	KBT23

△△ Kit not required. △△** Ice clumping issues may arise. * Rotocast finish N/A Not Applicable

** ICE1506 is compatible with B700-30, B1000-48, B1300-48, B1325-60 & B1600-60. *** BPF-1 used with B110 ONLY. If you have an older model B100 bin use the KBT5.

Side-by-Side Ice Machine Configurations

There are times when it is desirable to install 2 ice machines side by side on a bin. The reasons may range from gaining maximum output to creating redundancy. Ice-O-Matic offers an array of kits and bins with custom order tops for just such applications. The following table will help you create the system you need in a safe and cost effective manner.

Bin Model No.	Style	Application Bin Storage lbs (kgs)	Approximate Shipping Weight lbs (kgs)	CIM Series Cube Makers	ICE Series Cube Makers			Nugget Ice Makers	Flake Ice Machine
				30" (762 mm) wide	Two 22" (559 mm) wide	Two 30" (762 mm) wide	Two 48" (1,219 mm) wide	Two 21" (533 mm) wide	Two 21" (533 mm) wide
B25PP*	Slope Front	242 (110)	74 (34)	N/A	N/A	N/A	N/A	N/A	N/A
B40PS	Slope Front	344 (156)	103 (47)	N/A	N/A	N/A	N/A	N/A	N/A
B42PS	Slope Front	351 (160)	99 (45)	N/A	N/A	N/A	N/A	N/A	N/A
B55PS	Slope Front	510 (232)	125 (57)	N/A	N/A	N/A	N/A	N/A	N/A
B110PS	Slope Front	854 (388)	163 (74)	N/A	N/A	N/A	N/A	KBT22	KBT22

○ Must use remote or water cooled model only. △△ Kit not required. * Rotocast finish N/A Not Applicable

○* Must use remote or water cooled model only; ice clumping issues may arise. △△** Ice clumping issues may arise.



SLOPE FRONT STORAGE BINS

Dimensions

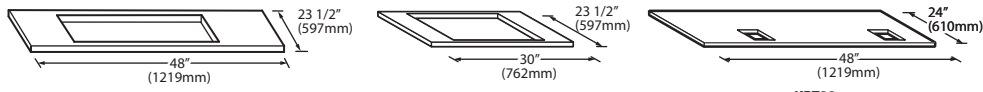
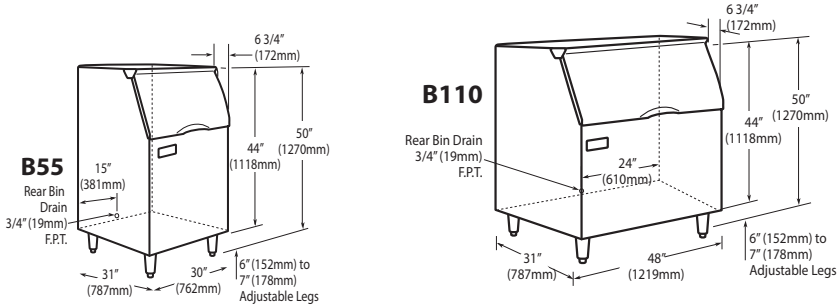
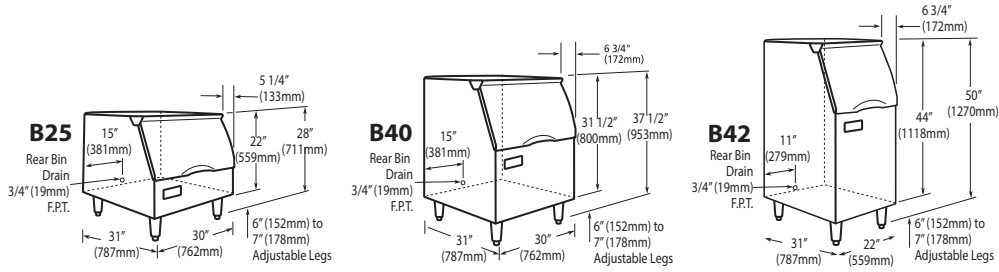

KBT5
Bin Top for 30" (762 mm) ICE series cuber including the ICE1506 family on a B100 bin

KBT19
Bin Top for 30" (762mm) bins with 22" (559mm) ICE Series Cube Ice Makers GEM Series Ice Makers & MFI Series Ice Makers

KBT22
Bin Top for 48" (1219mm) bins with (2) 21" (533mm) wide GEM Series Ice Makers & MFI Series Ice Makers

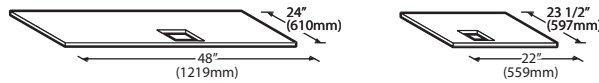

KBT23
Bin Top for 48" (1219mm) bins with (1) 21" (533mm) wide GEM Series Ice Makers & MFI Series Ice Makers

KBT24
Bin Top for 22" (559mm) bins with (1) 21" (533mm) wide GEM Series Ice Maker

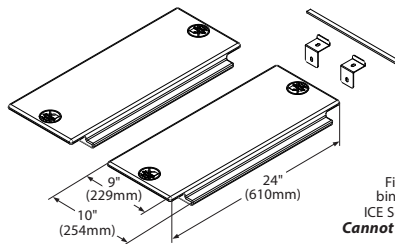

BPF-1
Filler Panel for B110 bins with 30" (762mm) ICE Series Cube Ice Makers
Cannot be used with the B100

NOTES:

Approx. Shipping Weight (lbs): B110 191 (87 kg) • B55 170 (77 kb) • B25 95 (43 kg) • B40 135 (61 kg) • B42 135 (61 kg)