

# OWNER'S MANUAL

## CAMBRO PRO CART ULTRA® FIXED RAIL MODELS

This manual applies to all Fixed Rail Pro Cart Ultra models:  
**PCU800, PCU1000, PCU1600, PCU2000, PCUL1000**

### CAUTION:

Please read all instructions before using this Product. Original instructions verified by Cambro Mfg. Co. are available in other languages.



### Table of Contents

I. Introduction.....	1
II. Safety Instructions and Warnings .....	2
III. Use & Capacity Guide .....	3
IV. Operating Instructions for Electric Use .....	4
V. Operating Instructions for Non-Electric Use.....	5
VI. Removing and Installing Modules.....	5
VII. Care & Maintenance .....	6
VIII. Troubleshooting Guide.....	7
IX. Replacement Parts .....	8
X. Cambro Warranty and Product Liability.....	10

### I. Introduction

Congratulations on the purchase of your new Cambro Fixed Rail - Pro Cart Ultra®! This Owner's Manual provides you with a step-by-step guide to operating and maintaining your new insulated transporter – versatile enough to hold hot or cold food. If you have any further questions, please contact your Cambro Sales Representative, visit [www.cambro.com](http://www.cambro.com) or call our **Customer Service Department at 800.833.3003** (International customers please call 714.848.1555).



Passive and /or  
Hot Models



ISO 7000-0790



ISO 7000-0790

Model # \_\_\_\_\_

Serial # \_\_\_\_\_

Date Installed \_\_\_\_\_

# CAMBRO®

[www.cambro.com](http://www.cambro.com)

## II. Safety Instructions and Warnings

**IMPORTANT:** Read all instructions prior to use and save for future reference.

- Follow all warnings marked on unit.
- Use only type of power supply (voltage, phase, frequency) indicated on the heater unit label.
- Do not use if power cord is frayed or damaged.
- Connect unit to properly grounded power source.
- Use only manufacturer authorized power cord and replacement parts.
- **Warning!** Do not use this equipment in wet or damp conditions.
- **Warning!** Unplug unit prior to cleaning or service.
- **Warning!** Do not submerge heater in water and never spray water on or near it.
- **Warning!** Do not get the thermometer wet in any way.
- **Warning!** Unplug the power cord before removing the hot or cold module.
- **Warning!** Only Cambro Authorized Service Agent or qualified foodservice equipment technician should open the inner cover of the heater for servicing.
- During normal operation, check the heating/cooling module fasteners for tightness at least once a week.
- Any operating problems not identified and corrected by instructions in this manual should be referred to a qualified service personnel (electrician or foodservice equipment technician).
- **Caution:** Maximum load for each rail set is 40 pounds (18,14 kg).
- **Warning!** Do not store explosive substances such as aerosol cans with flammable propellant inside the appliance.
- **Warning!** Do not place hot items directly on compartment bottom surfaces and never store anything on top of these carts.
- **Caution:** Maximum load for the products in this family:  
 PCU800 - 200Lbs (90,7Kg) / Empty weight - 102Lbs (46,3Kg)  
 PCU1000 - 250Lbs (113,4Kg) / Empty weight - 154Lbs (69,9Kg)  
 PCU1600 - 400Lbs (181,43Kg) / Empty weight - 171Lbs (77,57Kg)  
 PCU2000 - 500Lbs (226,8Kg) / Empty weight - 228Lbs (103,4Kg)  
 PCUL1000 - 500Lbs (226,8Kg) / Empty weight - 126.25Lbs (57,27Kg)
- Cleaning and user maintenance shall not be made by children without supervision.
- Children shall not play with the appliance.
- This appliance can be used by children aged from 8 years and above and persons with reduced physical, sensory or mental capabilities or lack of experience and knowledge if they have been given supervision or instruction concerning use of the appliance in a safe way and understand the hazards involved.



**Caution:** Metal heater housings are hot when cart is in use and can remain hot after use.

### IMPORTANT!

The conductor having green/yellow insulation shall only be connected to a terminal marked  or . If it is essential for the safety of the appliance, the tag shall be provided either with a wiring diagram showing the connection of the other conductors or with the following text:

For the connection of the other conductors, see the enclosed instructions for installation.

For all electric PCMHX(2) & PCMCX(2) modules, plug into 100-120 VAC, 60Hz (110v models) or 200-230 VAC, 50Hz (220v models) electrical receptacle. Product label located on the unit clearly indicates power requirements.

Electrical Specifications (Per Compartment)	Hot Module	Cold Module
REQUIRED VOLTAGE	115-230 VAC	115-230 VAC
AMPS	3.9a, 2.17a	3.6a, 1.7a
WATTS	450w @500v	414w @393v
HERTZ	50/60	50/60
PHASE	Single	Single
PLUG BODY TYPES AVAILABLE FOR THESE COUNTRIES	US, Canada, Mexico, China, Europe, UK, Ireland, Australia, South Africa, Japan	
POWER CORD LENGTH	9 ft./ 2,7 m	

\*If country or plug body type is not listed, please call Cambro Customer Service for details.

### III. Use & Capacity Guide

1. Fixed position spacing at 1.5" (38,1mm), molded-in rails are capable of holding up to 40Lbs (18,14Kg) per set but may get damaged if pan temperatures exceed 190F (87,8°C) while loading into the cart.
2. Pre-Heat or Pre-Chill each compartment for 30 minutes before adding your covered food pans to achieve the best temperature holding performance.
3. The fuller each compartment is, the better the holding performance will be.
4. This equipment is not intended to increase hot food temperatures or decrease cold food temperatures, but only to hold the food temperatures in a safe range for extended times.
5. Grip lids should be used on pans with a high liquid content to avoid spillage.
6. Best practice is to load HOT food pans from the top to the bottom in each compartment and on double compartment units, always load the bottom compartment first for best stability. Reverse this process for unloading.
7. Best practice is to load COLD food pans from the bottom to the top in each compartment and on double compartment units, load the bottom compartment first for best stability. Reverse this process for unloading.
8. Please provide at least a 6" (15,24cm) space at the rear of the cart for best performance of the Cold modules. The solid state cooling method requires this clearance and fresh air at 82F (27,8°C) or lower for best performance.
9. The convenient magnet latches provide ease of access when loading or unloading the compartments.
10. After loading all of your food into the compartment, latch the door with the plastic latches to provide the best holding performance and security of your food during transport.
11. The door thermometer is solar powered and can take up to 30 minutes to get accurate readings. The Unit of Measure can be changed between F & C degrees by removing the clear cover and simply moving the switch to your desired Unit of Measure then press the cover back in place.
12. Make sure to unplug the power cord from the power source before moving this product.
13. Casters on the PCU1600 and PCU2000 are all swivel with brake and the two located at the rear of the cart have swivel locks to help track on uneven surfaces.

TYPE of FOOD CONTAINER	PCU800 CAPACITY	PCU1000 CAPACITY	PCU1600 CAPACITY	PCU2000 CAPACITY	PCUL1000 CAPACITY
GN 1/1 Hotel Pans 2 1/2" (6,5 cm) Deep	12	14	24	28	14
GN 1/1 Hotel Pans 4" (10 cm) Deep	8	10	16	20	10
GN 1/1 Hotel Pans 6" (15 cm) Deep	6	6	12	12	6
GN 1/1 Hotel Pans 8" (20 cm) Deep	4	4	8	8	4
GN 1/2 Hotel Pans 2 1/2" (6,5 cm) Deep	24	NA	NA	NA	NA
GN 1/2 Hotel Pans 4" (10 cm) Deep	16	NA	NA	NA	NA
GN 1/2 Hotel Pans 6" (15 cm) Deep	12	NA	NA	NA	NA
GN 1/2 Hotel Pans 8" (20 cm) Deep	8	NA	NA	NA	NA
GN 1/3 Hotel Pans 2 1/2" (6,5 cm) Deep	36	NA	NA	NA	NA
GN 1/3 Hotel Pans 4" (10 cm) Deep	24	NA	NA	NA	NA
GN 1/3 Hotel Pans 6" (15 cm) Deep	18	NA	NA	NA	NA
GN 1/3 Hotel Pans 8" (20 cm) Deep	12	NA	NA	NA	NA

## IV. Operating Instructions for Electric Use (HOT)

**Note:** Units are designed to hold pre-heated hot food and pre-chilled cold food only. **ALWAYS** pre-heat or pre-chill unit. **NEVER** use to heat up or cool down food temperatures. **WARNING!** Not intended for use outdoors. **NEVER** use in wet or damp conditions. Refer to Section II for Safety Instructions and Warnings.

### Hot Electric Model:

- PCU800HH, PCU800HC, PCU800CH, PCU800HP & PCU800PH
- PCU1000HH, PCU1000HC, PCU1000CH, PCU1000HP & PCU1000PH
- PCU1600HH, PCU1600HC, PCU1600CH, PCU1600HP & PCU1600PH
- PCU2000HH, PCU2000HC, PCU2000CH, PCU2000HP & PCU2000PH
- PCUL1000H

### Operation:

Plug the power cord connector end into the Hot Module, then plug the other end into your power source 100vac - 240vac, 50/60 Hz. The display screen will light up showing the home screen; touch the word "Set" and a new screen will appear. This new screen will give you the option to choose F or C degrees Unit of Measure and a horizontal slider to adjust your temperature set-point.

Once you have made your choices, touch the word "OK" and the screen will go back to the home screen. touch the word "Start" on the GREEN field and the unit will start operating. Note; once the unit starts operating, the screen will show the word "Stop" on a RED field. This RED "Stop" button, if touched will end operation of the unit and return the button to a Green field with the word "Start". The letter "i" in the top left corner; once touched, will provide a run time/temperature graph. Touch the graph and the screen will return to the home screen.

**Factory Set at 160°F (71°C)**

**Adjustable from 70°F (21°C) TO 185°F (85°C)**

**Heat up time to 165°F (73,9°C) approx. 15 minutes**

Hot Module



## IV. Operating Instructions for Electric Use

### Cold Electric Model:

- PCU800CC, PCU800HC, PCU800CH, PCU800CP & PCU800PC
- PCU1000CC, PCU1000HC, PCU1000CH, PCU1000CP & PCU1000PC
- PCU1600CC, PCU1600HC, PCU1600CH, PCU1600CP & PCU1600PC
- PCU2000CC, PCU2000HC, PCU2000CH, PCU2000CP & PCU2000PC
- PCUL1000C

### Operation:

Plug the power cord connector end into the Cold Module, then plug the other end into your power source 100vac - 230vac, 50/60 Hz. Use the switch next to the connector to power the unit on and the display will light up showing two numbers; the top number is the actual compartment temperature and the bottom number is the Set point.

### Setting the Temperature:

1. Press the SET button one time, the bottom number will now flash.
2. Press the SET button to increase the desired temperature / Press the C/F button to decrease the desired temperature.
3. Do not press any buttons for three (3) seconds and the temperature will be set.

### How to set F or C units:

1. Press the C/F button to toggle between Celsius and Fahrenheit display.

**Factory Set at 32.5°F (,28°C) / Adjustable from 32.5°F (,28°C) TO 70°F (21°C) / Cool down time to 32.5°F (,28°C) approx. 90 minutes. MAX- Ambient room temperature must be no more than 90°F (32,2°C).**

COLD Module



## V. Operating Instructions for Non-Electric Use

### Non-electric (Passive Units) Models\*\*

#### Hot / Cold Holding Test Results for Passive Non-Electric Units

##### Hot Holding Test Results

**Hot** — temperature loss averaging 3°F/hour (1,5°C/hr).

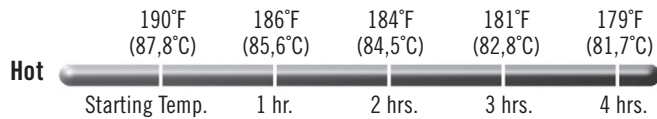

##### Cold Holding Test Results

**Cold** — temperature loss averaging 0.7°F/hour (0,4°C/hr).

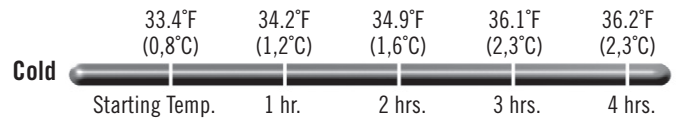

\*\*Based on test with 10 each 4" (10 cm) deep H-Pans™ with GripLids® filled with hot water at starting temperature of 190°F (87,8°C) held in compartment with door shut. Water temperature dropped an average of only 3°F (-1,61°C) /hr.

#### Transport Cart Operation:

- Before transporting or relocating the cart, ensure doors are shut and latched securely. If electric, turn off power, unplug and store the cord in the holding straps locate in the back of the cart.
- Insulated PCU carts will hold food at safe temperatures for 4+ hours unplugged\*\*. (see chart above).

## VI. Removing and Installing Modules

Tools Needed: Philips #3 Screwdriver (manual or electric)

**Caution:** Place cart against a wall or have a helper hold the module from the back so it doesn't fall out when the fasteners are removed.

1. Put the cart's brakes on, if applicable and make sure all supply cords are unplugged from the power source.
2. From the inside of the food storage compartment, carefully remove the 4 screws with washers at the corners of the module.
3. Push module from the inside if needed, (make sure there is someone to receive the unit or it is against a wall). Firmly grasp the module and remove it from the main body.
4. Make sure the module gasket is in place (this may require some tacky glue or wax to hold it in place in the groove on the body) and install the module into an opening on the back. Press the module firmly into the opening and ensure someone is there to hold it while another person installs the screws with washers from inside the food compartment.
5. Tighten the screws firmly but not excessively. DO NOT use tools other than a #3 Phillips screwdriver. During normal operation, periodically check screws for tightness.
6. Store modules when not in use in a cool, dry place away from grease and heat. DO NOT store on top of oven or on the cart. Cambro® Food Storage Box DB18266CW (sold separately) is a suitable storage option.

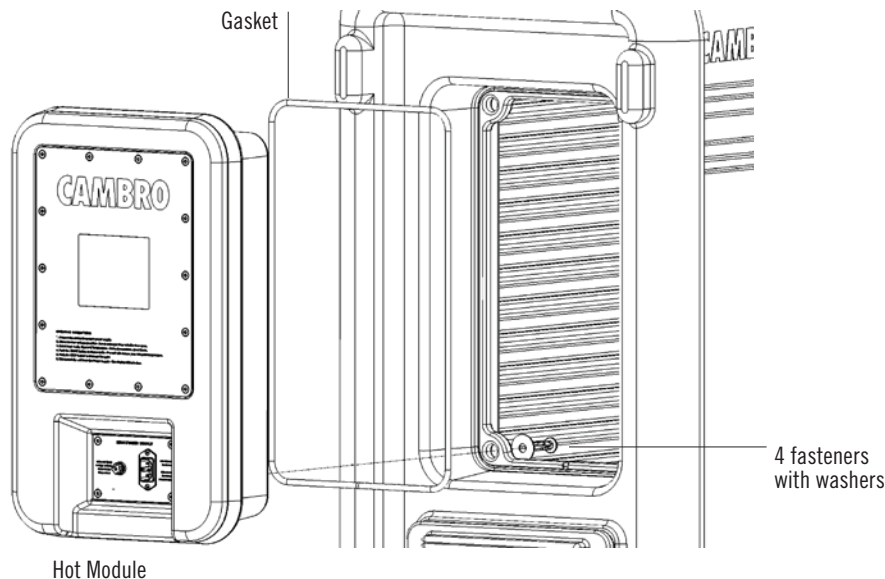

**⚡ WARNING ELECTRIC SHOCK HAZARD**

**MODULES:**

**WARNING!** Completely cool heater unit prior to cleaning or maintenance.

**WARNING!** Do not submerge Hot or Cold module in water or spray water on it.

**CLEANING INSTRUCTIONS**

1. Remove power from the unit prior to cleaning.
2. DO NOT use pressurized cleaners or a water hose to clean this unit.
3. Clean with mild detergent, hot water and a soft cloth. DO NOT use detergents or cleaners containing ammonia or bleach.
4. Hand wash using a soft cloth or brush to clean all interior and exterior surfaces. DO NOT use steel wool or abrasive scrub pads or brushes compartment.
5. Clean the control display panel with a soft cloth without chemicals. Avoid scrubbing and damaging any safety or electrical labeling.
6. Air dry or dry cart outside and inside with clean, dry, soft cloth. DO NOT power the unit unless everything has dried.

**TO REMOVE ANY LINGERING SCENTS AND STAINS:**

Use an odor removing soak or sanitizer to remove scents and stains that can occur from holding products with strong odors.

- A diluted solution of 2-3 tablespoons of baking soda per gallon of hot tap water or 1 part lemon juice or vinegar to 4 parts hot water is also an effective way to remove lingering odors.
- Rinse thoroughly with hot water and dry.

**CASTER MAINTANANCE:**

To be performed every 6 months or after unit has been washed or steam cleaned: Wheel and swivel bearings last longer if lubricated regularly. Some lube applied to friction points on the wheel hub, washer and leg surfaces of straight roller bearing systems reduces drag and improves reliability. Normal conditions may warrant lubrication every six months, but once a month may be necessary in extreme applications, such as corrosive or exceptionally dirty environments. Cart washings may necessitate lubrication after each wash.

1. Grease swivel raceway of caster using a lubricant such as Lubriplate No. 930-AA, Keystone #84EPXLT multi-purpose grease or the equivalent. Moving "O" Ring or seal with finger, apply grease using a grease gun with a needle nose adapter or a tube-type applicator such as "Sta-lube" Moly-graph Assembly Lube. These can be obtained at most auto parts stores.
2. Use a light oil such as WD-40 on the nylon bushing at the hub. Check caster for any damage and test caster spin and swivel rotation before returning to service.

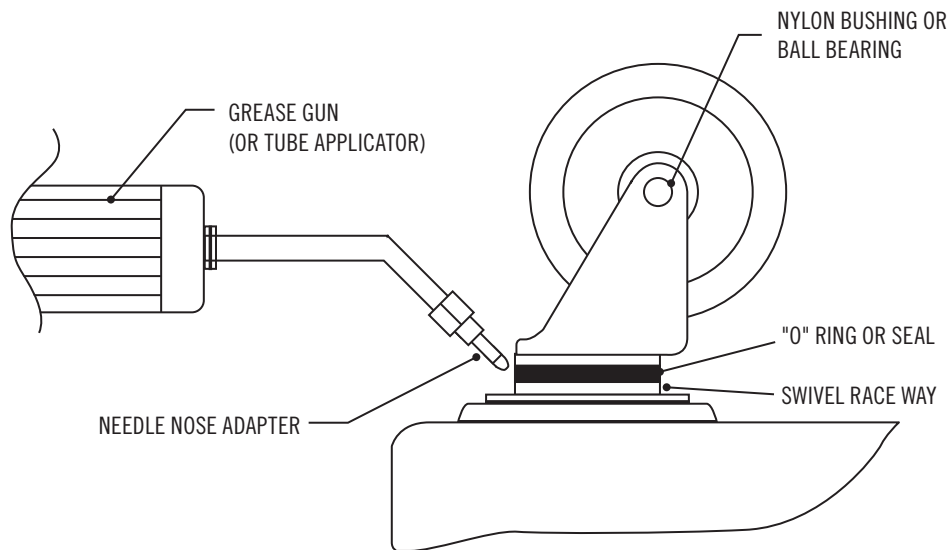

## VIII. Troubleshooting Guide

**Warning!** *Hazard of Electric Shock* — Disconnect power supply before servicing. Any operating problems not identified and corrected by instructions in this manual should be referred to qualified service personnel (electrician or foodservice equipment technician). No user-serviceable items under the inner cover of the electrical units. Only qualified service personnel should open the inner cover of any electrical device.

Problem	Possible Causes	Possible Solutions
Unit is plugged in but does not heat or cool at all.	<ul style="list-style-type: none"> <li>• There is no power or an inadequate amount of power.</li> <li>• Power cord is not fully connected to the power source or to the heater.</li> <li>• Power cord is damaged.</li> <li>• Heating or cooling unit is damaged.</li> </ul>	<ul style="list-style-type: none"> <li>• Check the power supplied to the unit. It should match the requirements on the heater label.</li> <li>• Make sure both ends of the power cord are connected securely.</li> <li>• Always replace damaged power cords with Cambro authorized power cords.</li> <li>• Replace the heater or cooling unit. Contact Cambro Customer Service.</li> </ul>
Unit operates for more than 1 hour but does not achieve the expected temperature.	<ul style="list-style-type: none"> <li>• Door is not fully closed.</li> <li>• Power cord is damaged and is causing intermittent power to the heating unit.</li> <li>• Thermometer is damaged or not working properly.</li> <li>• Heating unit is not working properly.</li> </ul>	<ul style="list-style-type: none"> <li>• Make sure the door is fully closed. Small gaps are ok and will not affect the performance.</li> <li>• Always replace damaged power cords with Cambro authorized power cords.</li> <li>• Check the temperature inside the compartment with a verified thermometer, placed in the center of the compartment.</li> <li>• Check fans for obstructions. If none found, replace unit. Contact Cambro Customer Service.</li> </ul>
Persistent odor inside the cabinet.	<ul style="list-style-type: none"> <li>• Initial start-up of unit.</li> <li>• Food left in the cabinet for overly-long holding periods.</li> </ul>	<ul style="list-style-type: none"> <li>• For first-time use, plug in and run the unit with the door open for 1 hour to air out the cabinet.</li> <li>• Place a pan of water with some baking soda in it and turn on the heater for 1 hour.</li> <li>• If smell is still persistent please contact Cambro Customer Service.</li> </ul>
Unit stopped heating or cooling during normal operation.	<ul style="list-style-type: none"> <li>• The compartment temperature exceeded 190°F (87.8°C), causing the hi-limit thermostat to shut power off to the heater.</li> </ul> <p><b>NOTE:</b> Fan may remain running.</p> <ul style="list-style-type: none"> <li>• Fans are not operating properly.</li> <li>• Control unit is not working properly.</li> </ul>	<ul style="list-style-type: none"> <li>• Unplug heater and let it cool off to Reset the Heater. Plug back in after cooled.</li> <li>• Replace Fans. Fans on the cooling unit are critical. Contact Cambro Customer Service.</li> <li>• Replace control unit. Contact Cambro Customer Service.</li> </ul>

**NOTE:** For service please contact Cambro at 800-854-7631 X4118. Please refer to the heater model number (see page 4) when you call in. Units under warranty should be serviced by Cambro Authorized Service Agent Only.

### Cold Module Display Error codes:

In normal operation, the probe temperature will be displayed. The display blinks when waiting for a parameter to be saved or when there is an error saving a parameter to memory. The following messages can also appear:

**ERP1** Probe Error (check wiring or replace probe)

**Eri** Internal Parameter Error (factory default programming)

**ALH** Low Temperature Alarm

**000** Open Probe Error

--- Short Circuited Probe Error

Please contact service if problem persists.

## IX. Replacement Parts

### REPLACEMENT PARTS

1. 6 inch Casters – PCU800, PCU1000
2. 6 inch HD Casters -PCU1600, PCU2000, PCUL1000
3. Plastic latch.
4. Metal door hinge
5. Clear plastic menu panel
6. Hot Module
7. Cold Module

The model number of the Cambro cart is required to determine the correct replacement part. The cart model number can be found on the left side of the cart. Each electrical item has a label marked with serial and model number. For all electric and non- electric models that begin with the prefix PCU:

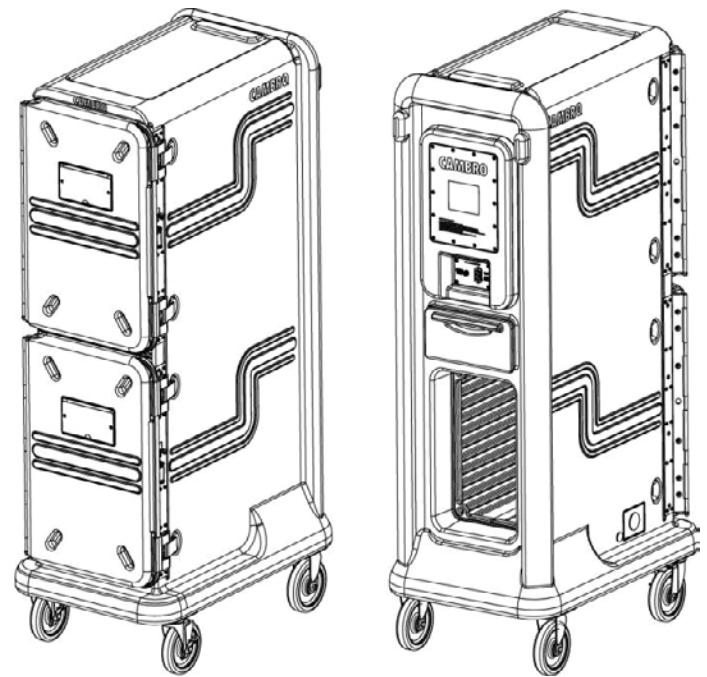

#### TO ORDER REPLACEMENT PARTS:

- Call Cambro Customer Service at 800 833 3003 or
- Call International 714 848 1555
- Fax your order to 714 842 3430 or
- Call your local Cambro Representative or Distributor

## IX. Hitch Installation Instructions

### REPLACEMENT PARTS - PCU2000 & PCU1600 ONLY

1. Place cart on it's side.
2. Line up Chassis Plates with molded-in steel threaded inserts.
3. Use Hex Head Bolt and a washer with each bolt. Tighten snug (Do Not overtighten). Use removable thread-locker.
4. Attach Hitch Ball (if using) and Tow Bar.
5. Insert Locking or Non-Locking Pin to secure.

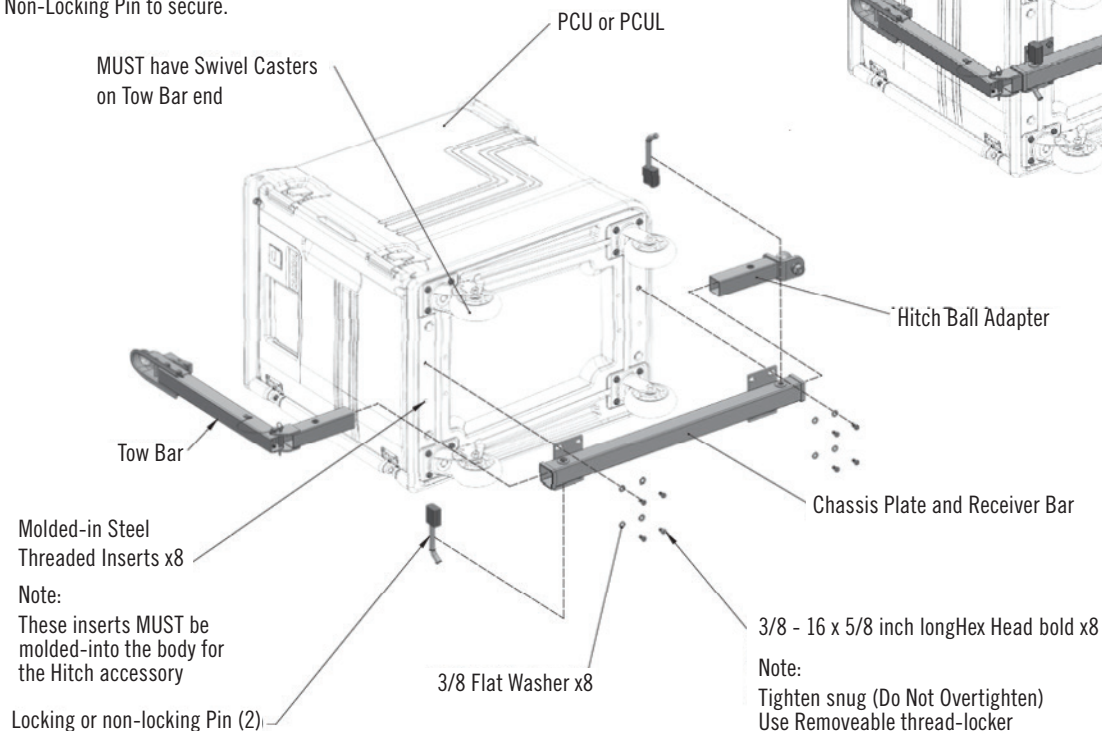

**WARNING!** Components and Cart, with installed Hitch are **NOT** intended for use on the STREET or HIGHWAY. Pulling speed should **NOT** exceed ten (10) miles per hour. When the Tow Bar is not in service, it should be pinned in the vertical position or completely removed from the cart to reduce a trip hazard.

**CAUTION!** Careful attention is required while towing these carts. It is **NOT** recommended to connect more than six (6) carts together. Unplug power before moving and confirm all doors are closed and latched.

## X. Cambro Warranty and Product Liability

### LIMITED ORIGINAL COMMERCIAL ELECTRICAL EQUIPMENT WARRANTY

Cambro Manufacturing warrants its new product(s) to be free from defects in material and workmanship for a period of one (1) year from the date of shipment from authorized CAMBRO distribution locations.

This Warranty is subject to the following conditions and limitations:

1. This warranty is limited to product(s) sold by Cambro Manufacturing to the original user in the continental United States and Canada. For International Warranty Claims contact your local Cambro Representative.
2. The Liability of Cambro Manufacturing is limited to the repair or replacement of any part found to be defective. Parts and labor required for preventative maintenance or cleaning are not covered under this warranty.
3. Cambro Manufacturing will bear normal charges incurred in the repair or replacement of a warranted piece of equipment within 50 miles (80 kilometers) of an authorized service agency. Time and travel charges in excess of 50 miles (80 kilometers) will be the responsibility of the person or firm requesting the service. All labor to repair and/or service the warranted unit(s) shall be performed during regular working hours. Overtime premium will be charged to the buyer and is NOT covered by this warranty.
4. Charges incurred by delays or operating restrictions that hinder the service technician's ability to access or perform service to equipment in question are NOT covered by this warranty. This includes Institutional, Correctional, Military, and marine facilities.
5. Cambro Manufacturing will bear no responsibility or liability for any product(s) which have been mishandled, abused, misapplied, misused, subjected to harsh chemical action, damaged by flood, fire, or other acts of nature, field modified by unauthorized personnel or which have altered or missing serial numbers.
6. Cambro Manufacturing does not recommend or authorize the use of any product(s) in a non-commercial application, including but not limited to residential use. The use or installation of any product(s) in non-commercial applications renders all warranties, express or implied, including the warranties of MERCHANTABILITY and FITNESS FOR A PARTICULAR PURPOSE, null and void, including any responsibility for damage, costs and legal actions resulting from use or installation of product(s) in any noncommercial setting.
7. Adjustments such as calibrations, leveling, tightening of fasteners or utility connections normally associated with the original installation are the responsibility of the dealer or installer and not that of Cambro Manufacturing. Improper installation includes, but is not limited to, use of inadequate electrical wiring and/or insufficient or improper voltage.
8. Replacement part(s) which are replaced in the field by CAMBRO authorized service technicians ONLY will be warranted for the duration of the equipment warranty or 90 days effective from date of installation, whichever is greater. This warranty is for part(s) cost only and does not include freight or labor charges.
9. This states the exclusive remedy against Cambro Manufacturing relating to the product(s), whether in contract or in tort or under any other legal theory, and whether arising out of warranties, representations, instructions, installations or defects from any cause. Cambro Manufacturing shall not be liable, under any legal theory, for loss of use, revenue or profit, or for substitute use of or performance, or for incidental, indirect, or special or consequential damages or for any other loss or cost of a similar type.
10. THIS WARRANTY AND THE REPRESENTATIONS AND TERMS SET FORTH HEREIN ARE EXCLUSIVE AND IN LIEU OF ALL OTHER WARRANTIES AND LIABILITIES, INCLUDING BUT NOT LIMITED TO, OTHER WARRANTIES, EXPRESS OR IMPLIED, OF MERCHANTABILITY AND FITNESS FOR PARTICULAR USE AND CONSTITUTES THE ONLY WARRANTY OF CAMBRO MANUFACTURING WITH RESPECT TO THE PRODUCT(S).

**RETURN POLICY:** Cambro Manufacturing products cannot be returned without prior written factory authorization (**RMA**). The restocking charge is 15% plus any costs required to recondition the equipment. No returns accepted after 90 days from date of invoice. Electrical components returned are subject to inspection prior to credit being issued. Electrical components which have been installed by an operator or non-approved service agent are not returnable for credit.



Customer Service 800 833 3003  
© Cambro Manufacturing Company, Huntington Beach, California 92647  
Printed in USA 06/25