

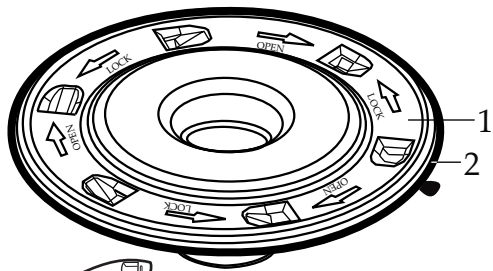

One Gallon Variable Speed Blender CB15V

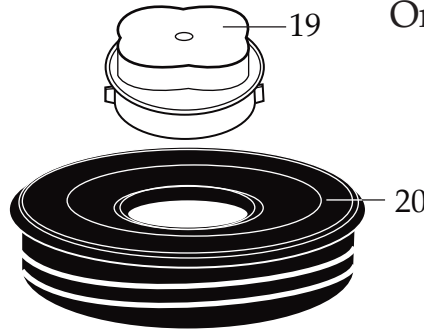

CBL10
Hot Blending Lid
(optional)

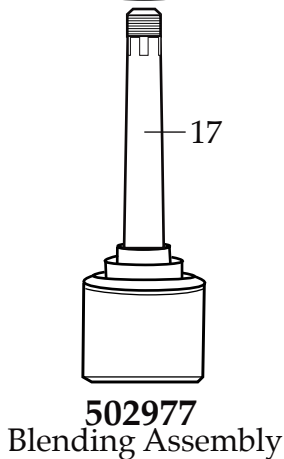
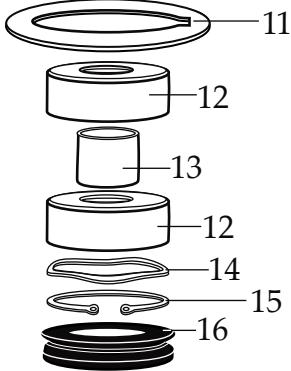
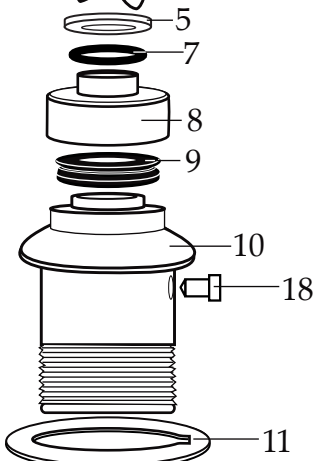
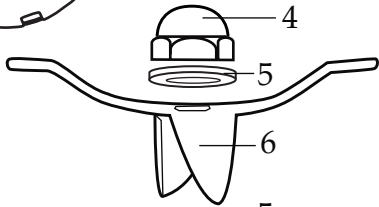
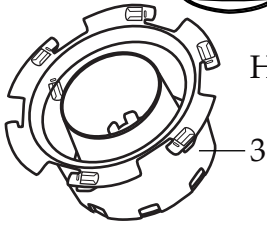

Unit Information
3 Limited Motor Warranty
15.0 Amps.
1,700-18,500 RPM's (no load)

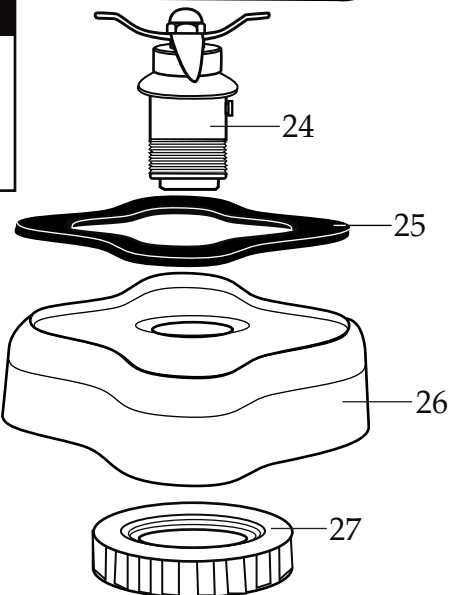
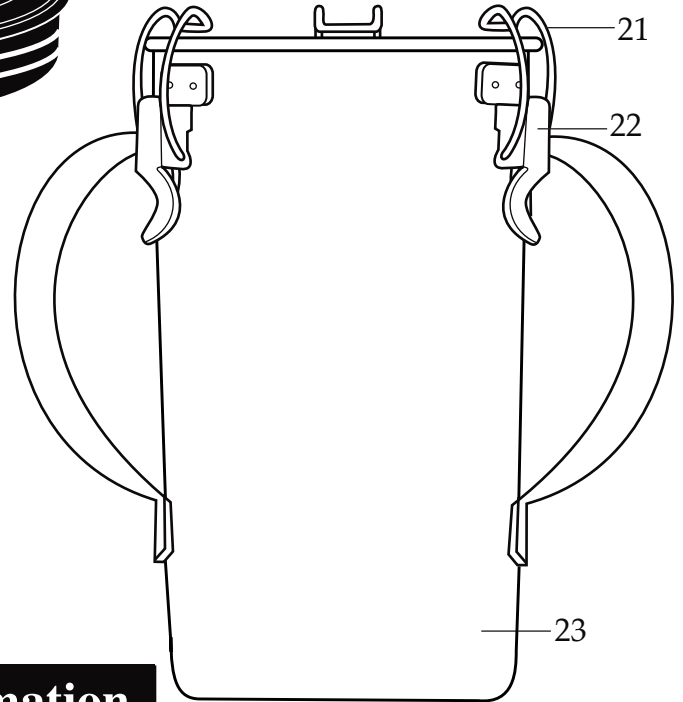

502235
Container with Blending Assembly
704587
Container Complete with Lid

WARING COMMERCIAL®

Blender Unit Components CB15V

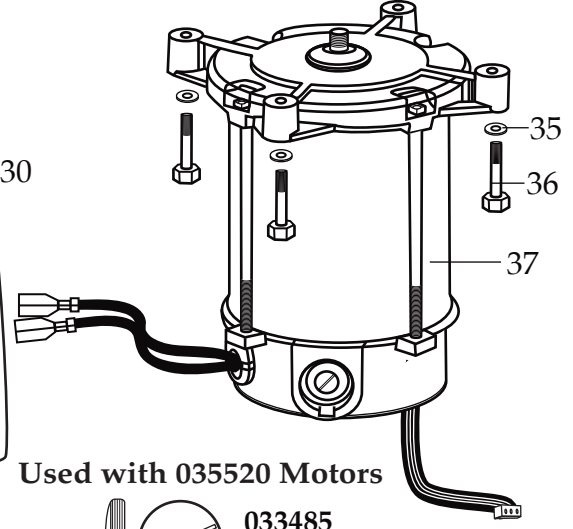
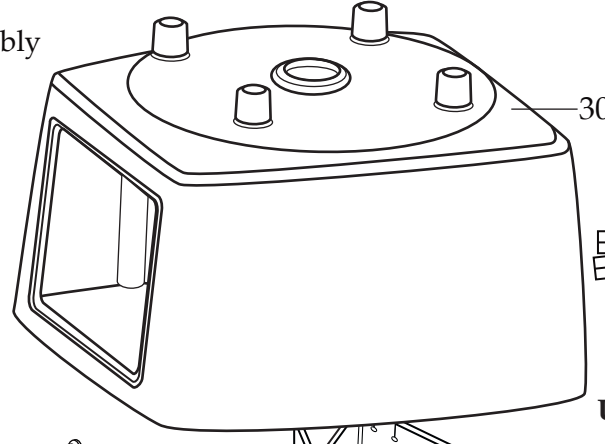
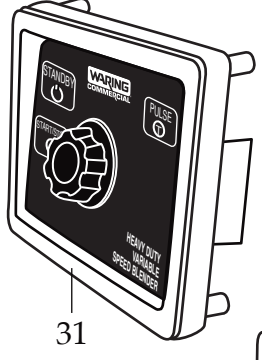
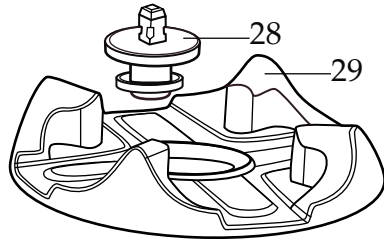
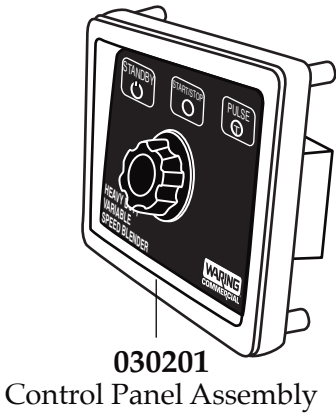

Used with 035520 Motors

- 033485
Brush Cap
(2 required)
- 027381
Brush & Spring Assembly
(2 required)

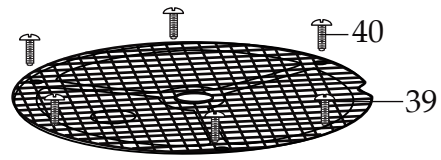
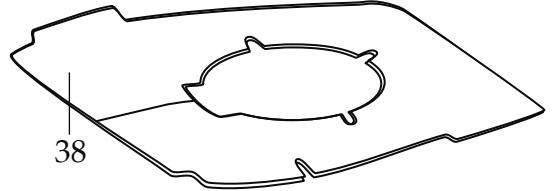

Date Code Location
YY|MM|DD
year year|month month|day day

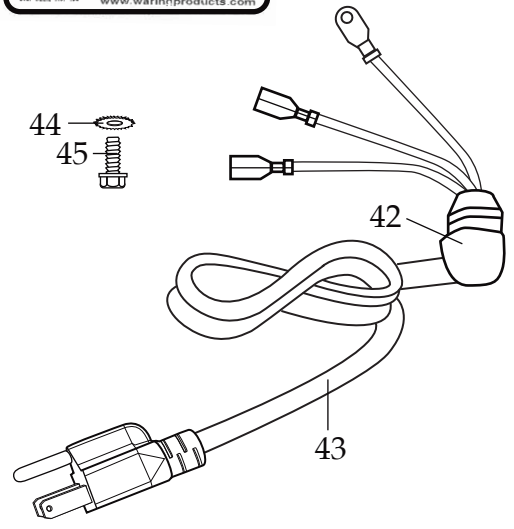
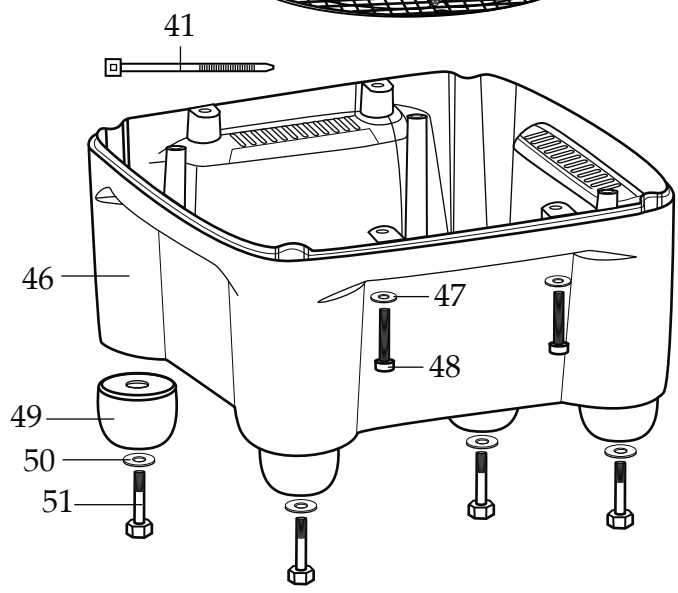

Catalog#

CB15V *(after 9/27/2016)*
 Convert Back
 to CB15V

Model

CB15VG CB15V CB15VS
(after 2/25/2016) *(after 10/7/2010)*



Illustration#	Part#	Description
1	024000	Hot Blending Outer Lid
2	026496	Hot Blending Outer Lid Gasket
3	023998	Hot Blending Baffle Cup
4	002972	Cap Nut
5	027581	Flat Washer (2 required)
6	027683	Blade
7	018389	"O" Ring
8	027582	Bearing Cap
9	018390	Small "V" Ring
10	023934	Bearing Holder
11	004946	Washer
12	018386	Bearing (2 required)
13	023926	Spacer
14	023907	Spring Washer
15	023927	Retaining Ring
16	023906	Large "V" Ring
17	023933	Drive Shaft
18	025817	Key
19	028530	Cover Insert
20	028226	Outer Lid
21	008791	Latch Wire (3 required)
22	502773	Bracket Assembly (spot welded to container 3 required)
23	023909	Double Handle Container
24	502977	Blending Assembly
25	004949	Container Support Gasket
26	025571	Container Support
27	012008	Lock Nut
28	503328	Coupling
29	025871	Jar Pad
30	028025	Top Housing <i>(changed after 9/17/2010)</i>

Catalog#

CB15V

(after 9/27/2016)
Convert Back
to CB15V

CB15VG

*(after 2/25/2016)***Model**

CB15V

CB15VS



Illustration#	Part#	Description
31	503527 030201	Control Panel Assembly Relabeled <i>(on units after 5/25/2018)</i> Control Panel Assembly
32	029888	Control Panel Rear
33	026497	Screw (4 required)
34	030453	Control Panel Baffle <i>(on units after 9/27/2016)</i>
35	002984 003344 002984	Washer (4 required <i>on units after 9/27/2016</i>) Washer (4 required <i>on units after 2/25/2016</i>) Washer (4 required)
36	016691 019098 016691	Bolt (4 required <i>on units after 9/27/2016</i>) Screw (4 required <i>on units after 2/25/2016</i>) Blot (4 required)
37	035520 029875 503472 029875 503323 029875	Leili Motor <i>(changed after 11/8/2017)</i> ECM Motor with MTP & Sensor <i>(on units after 9/27/2016)</i> Groscopp Motor Modified <i>(on units after 2/25/2016 use 036445)</i> ECM Motor with MTP & Sensor <i>(on units after 8/8/2013)</i> Motor with Sensor <i>(on units after 9/12/2012)</i> ECM Motor with MTP & No Sensor
38	026318 035355 026318	Baffle <i>(on units after 9/27/2016)</i> Baffle <i>(on units after 2/25/2016)</i> Baffle
39	018791	Screen
40	026500	Screw (6 required)
41	013731 013731	Cable Tie (2 required <i>on units after 3/14/2013</i>) Cable Tie (5 required)
42	018811	Strain Relief
43	503329	Cord Set
44	002943	Ground Washer
45	027278	Ground Screw
46	026317	Bottom Housing
47	002984	Washer (4 required)
48	026412	Screw (4 required)
49	026296	Foot (4 required)
50	018314	Washer (4 required)
51	026493	Screw (4 required)

Catalog#

CB15V *(after 9/27/2016)*
 Convert Back
 to CB15V

Model

CB15VG *(after 2/25/2016)* CB15V *(after 10/7/2010)* CB15VS

Waring Factory Service Center
 314 Ella T. Grasso Ave.
 Torrington, CT 06790
 Tele. 1-800-269-6640

COMMERCIAL
 Fax 860-496-9017
 www.waringcommercialproducts.com

Groschopp Motor Parts No Longer Used

(on units after 2/25/2016 thru 9/27/2016)

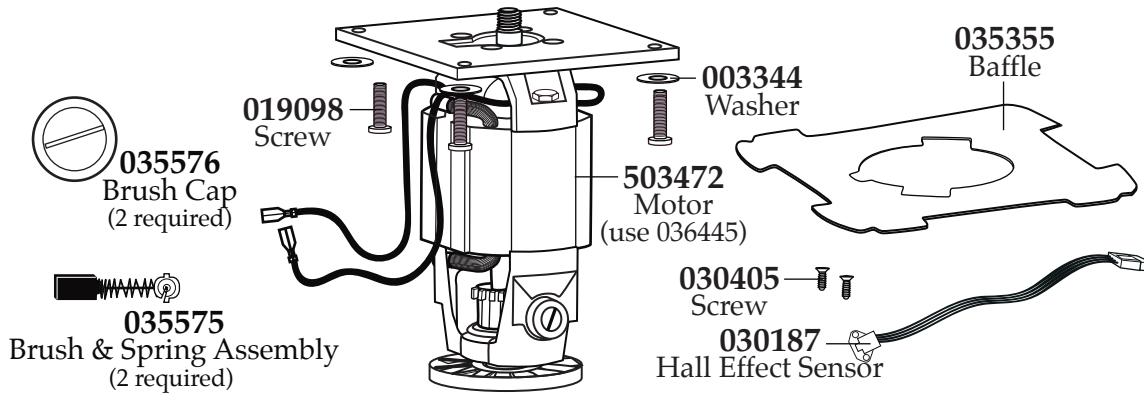

036445
CB15 Groschopp Motor Replacement Kit

