

Combitherm® CTC7-20G

Gas Boiler-free

ALTO-SHAAM

Combining multiple cooking functions into a single appliance, Combitherm® ovens provide endless versatility, reliability and unmatched performance. An all-in-one solution for efficient and consistent food production. Combitherm ovens do the work of a convection oven, kettle, steamer, fryer, smoker and more. Execute every dish, no matter how simple or complex, faster than ever with flawless precision and consistency.

Standard features

- Simple and intuitive push button control that commands all oven functions with easily identifiable icons
- LED display indicating cooking mode, temperature settings, time remaining, and various instructions
- LED illuminated door handle designed for the needs of the busy kitchen, and provides visual notification of the oven status
- CoolTouch3™ triple panel glass door keeps the heat inside, while keeping the glass cool to the touch and providing 15% greater thermal retention to improve performance and efficiency
- Three cooking modes—steam, convection, and combination
- Front-accessible and retractable rinse hose
- Two different fan speeds
- One fully automated cleaning cycle



- 8** Eight, full-size sheet pans or eight GN 2/1 pans; sixteen full-size or GN 1/1 pans, two rows deep
- 2** Two side racks with eight non-tilt support rails; 19-7/8" [505mm] horizontal width between rails, 2-3/4" [70mm] vertical spacing between rails
- 168 lb [76 kg] product maximum
- 105 quarts [133 liters] volume maximum
- Four [4] wire shelves included. Additional wire shelves required for maximum capacity.

Condensable Particulate Matter (CPM) emissions produced through the most aggressive testing methods available were measured at 0.77 mg/m³ for 11,660 beef patties which is below the maximum allowable level of 5.0 mg/m³ established by EPA test method 202.



CTC7-20G

Configurations (select one)

Door swing

- Right hinged
- Recessed door, optional; increases oven width by 5" [127mm]

Electrical

- 120V 1ph
- 208-240V 3ph
- 380-415V 3ph

Gas type

- Natural
- Propane

Accessories (select all that apply)

- CombiLatch™
- Stacking hardware
- Seismic feet package, optional
- Extended one-year warranty

Probe choices

- Removable, single-point, quick-connect core temperature probe, optional
- Removable, single-point, quick-connect sous vide temperature probe, optional

Water treatment

- RO system OPS175CR/5 [5031203]

Security devices for correctional facility use

- Optional base package [not available with recessed door]; includes tamper-proof screw package, excludes temperature probe
- Anti-entrapment device, optional
- Control panel security cover, optional
- Hasp door lock [padlock not included], optional
- Removable, single-point, quick-connect core temperature probe, optional

Installation options (select one)

- Alto-Shaam Combination Factory Authorized Installation Program - available in the U.S. and Canada only
- Installation Start-Up Check - available through an Alto-Shaam authorized service agency



Combitherm® CTC7-20G



Specification

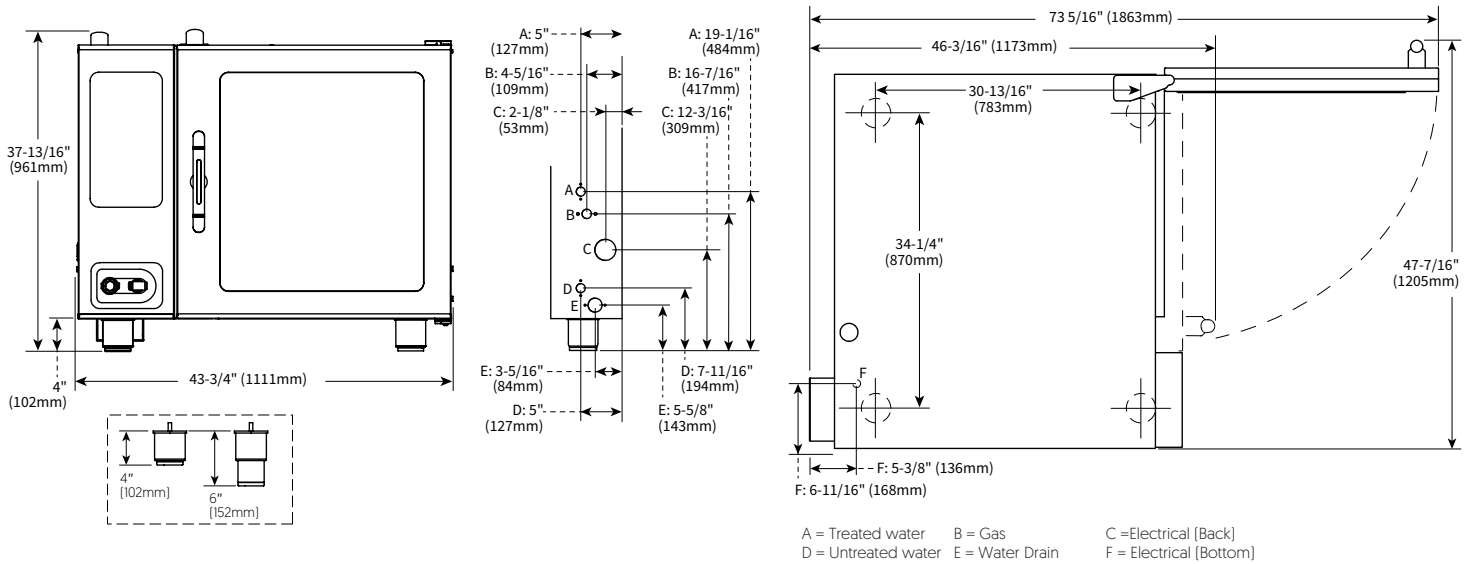

DIMENSIONS

Model

CTC7-20G

Exterior (H x W x D)

37-13/16" x 43-3/4" x 46-3/16" [961mm x 1111mm x 1173mm]

Exterior with recessed door (H x W x D)

37-13/16" x 48-3/4" x 46-3/16" [961mm x 1238mm x 1173mm]

Ship Dimensions (L x W x H)*

CTC7-20G 56" x 49" x 51" [1422mm x 1245mm x 1295mm]

*Domestic ground shipping information. Contact factory for export weight and dimensions.

Interior (H x W x D)

23-1/4" x 24-1/4" x 32-3/4" [590mm x 616mm x 832mm]

Net Weight

680 lb [308 kg]

Ship Weight*

728 lb [330 kg]



CLEARANCE

Top: 20" [508mm]

Left: 0" [0mm]

18" [457mm] recommended service access

Right: 0" [0mm] Non-combustible surfaces

2" [51mm] combustible surfaces

Bottom: 5-1/8" [130mm]

Back: 4" [102mm]

4-5/16" [109mm] optional plumbing kit



CHECK FIRST

- Oven must be installed level.
- Water supply shut-off valve and back-flow preventer when required by local code.
- Hood installation is required.
- Drain must not be located directly underneath the appliance.



Heat of rejection

CTC7-20G	Heat Gain qs, BTU/hr	Heat Gain qs, kW	Heat Gain qs, Mj/hr
	549	0.16	68.6



Noise emissions

A maximum 67 dBA was measured at 3.3 ft [1 m] from unit as tested on CTP10-20E.

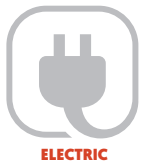

	CTC7-20G	V	Ph	Hz	Awg (mm ²)	A	Breaker	kW	Connection	Certification
†	120V*	120	1	60	12 [3.31]	7.0	20	.84	L1, L2/N, G	
†	208-240V	208	3	50/60	14 [2.08]	4.8	15	1.0	L1, L2, L3, G	
		240	3	50/60	14 [2.08]	4.2	15	1.0	L1, L2, L3, G	
	380-415V	380	3	50/60	14 [2.08]	4.6	15	1.0	L1, L2, L3, N, G	
		415	3	50/60	14 [2.08]	4.2	15	1.0	L1, L2, L3, N, G	

† Per UL requirements, must be permanently connected to electrical supply source.

*Ground fault or residual current protection device must accommodate a leakage current of 20mA.

- Electrical connections must meet all applicable federal, state, and local codes.
- For use on individual branch circuit only.
- Ovens are not supplied with an electrical cord or plug.



Water requirements (per oven)

- Two cold water inlets - drinking quality
- One treated water inlet: 3/4" NPT connection. Line pressure 30 psi minimum dynamic and 90 psi maximum static [200-600 kPa] at a minimum flow rate of 0.26 gpm [1 L/min].
- One untreated water inlet: 3/4" NPT connection. Line pressure 30 psi minimum dynamic and 90 psi maximum static [200-600 kPa] at a minimum flow rate of 2.64 gpm [10 L/min]. Water drain: 1-1/2" [40mm] connection with a vertical vent to extend above the exhaust vent. Materials must withstand temperatures up to 200°F [93°C].

Water Quality Standards

It is the sole responsibility of the owner/operator/purchaser of this equipment to verify that the incoming water supply is comprehensively tested and, if required, a means of "water treatment" provided that would meet compliance requirements with the published water quality standards shown below. Non-compliance with these minimum standards will potentially damage this equipment and/or components and void the original equipment manufacturer's warranty. Alto-Shaam recommends using the Alto-Shaam Reverse Osmosis System to properly treat your water.

Inlet Water Requirements		
Contaminant	Treated Water	Untreated Water
Free Chlorine	Less than 0.1 ppm [mg/L]	Less than 0.1 ppm [mg/L]
Hardness	30-70 ppm	30-70 ppm
Chloride	Less than 30 ppm [mg/L]	Less than 30 ppm [mg/L]
pH	7.0 to 8.5	7.0 to 8.5
Silica	Less than 12 ppm [mg/L]	Less than 12 ppm [mg/L]
Total Dissolved Solids [tds]	50-125 ppm	50-360 ppm



Clearance requirements for water filtration system

Do not install a water filtration system behind unit.



Gas Requirements (gas type must be specified on order)
Hook-up: 3/4" NPT

UL Marked Appliances	Maximum Input BTU/h	Minimum Input BTU/h	Maximum Inlet Pressure Inches WC	Minimum Inlet Pressure Inches WC	Maximum Fuel Consumption*	
					CFH	GPH
Natural Gas	85,000	65,000	14.0	5.5	81.0	N/A
Propane				9.0	34.0	0.9

*Assumes an average heating value for natural gas to be 1,050 BTU/SCF and a specific gravity of 0.60. The assumed value for propane gas is 2,500 BTU/SCF, and a specific gravity of 1.53.

AGA Marked Appliances	Maximum Input MJ/h	Minimum Input MJ/h	Maximum Inlet Pressure kPa	Minimum Inlet Pressure kPa	Maximum Fuel Consumption	
					m ³ /h	L/h
Natural Gas	89.7	68.6	3.48	1.13	2.4	N/A
Propane				2.75	0.9	3.5

CE Marked Appliances	Maximum Input		Minimum Input		Nominal Gas Pressure mbar	Maximum Gas Pressure mbar	Maximum Fuel Consumption m ³
	kWh (Hs)	kWh (Hi)	kWh (Hs)	kWh (Hi)			
2E (G20)	25.0	22.5	20.0	18.0	20	50	2.4
2LL (G25)					20		2.8
3P (G31)	24.5	22.5	19.5	18.0	37		0.9
3B/P (G30)					29		0.9

CONTACT US

W164 N9221 Water Street | Menomonee Falls, Wisconsin 53051 | U.S.A.
 Phone: 262.251.3800 | 800.558.8744 U.S.A./Canada | Fax: 262.251.7067 | alto-shaam.com