

robot coupe®



COMBINATION PROCESSORS: BOWL CUTTER AND VEGETABLE PREP

R502 • R502VV • R702 • R702VV • R752VV



RESTAURANTS - CATERERS

CUTTER function

3 blade assemblies available, sharpened to suit every type of task.



R702 - R702VV – R752VV

All stainless steel detachable adjustable blade assembly.

Smooth blade

Supplied as standard



COARSE CHOPPING



FINE CHOPPING



SAUCES, EMULSIONS

Serrated blade

Optional extra



KNEADING



GRINDING

Fine serrated blade

Optional extra



CHOPPING HERBS



GRINDING SPICES

2 SPEEDS

R502 and R702
3-phase models
900 rpm - 1800 rpm

VARIABLE SPEED

R502VV, R702VV
and R752VV
Single-phase models
300 to 3500 rpm

R-MIX®

R502VV, R702VV
and R752VV
- **60 - 500 rpm** variable speed
with reverse rotation.
- Mixing thin slices of meat
or incorporating chunky
ingredients into terrines, cakes
or brioche.

R502 – R502VV



Food processors : Cutters & vegetable slicers 2 machines in 1!



R702 – R702VV – R752VV

R502 Vegetable Preparation Function

Large hopper:

139 cm² ideal for processing vegetables such as cabbage, celeriac, lettuce or tomatoes.



Cylindrical hopper:

Ø 58 mm for uniform cutting of long vegetables.



Exactitube pusher:

Ø 39 mm for slicing small-size ingredients such as chillis, gerkins, dry sausage, asparagus, spring onions, bananas, strawberries and grapes.



R502 - R752 Cutter Function

Scraper arm:

Designed to easily scrape the lid and edges of the bowl without stopping the machine.



Lid:

Liquids and other ingredients can be added during processing.



Timer:

Less effort, greater precision and more regular results no matter what the recipe.



Ergonomic Soft Touch handle:

Greater user comfort and more comfortable grip.



R 752 Vegetable Preparation Function

Extra large hopper:

Up to 15 tomatoes or 1 whole cabbage.



Cylindrical hopper:

Ø 58 mm uniform cutting of long ingredients.



Exactitube pusher:

Ø 39 mm for slicing small-size ingredients such as chillis, gerkins, dry sausage, asparagus, spring onions, bananas, strawberries and grapes.



5.9 L
stainless-steel
bowl



7.5 L
stainless-steel
bowl



Lever with assisted movement:



- Requires less effort
- Prevents MSD*
- Takes away the tediousness



VERSATILE

Multifunctional food processor

- **Cutter function:** for chopping, emulsifying, kneading, grinding and making sauces.
- **Vegetable preparation function:** for slicing, grating, ripple cutting, julienne, dicing, fries and mashing.



PERFORMANCE

- **Bowl-base twin-blade assembly:** to process both large and small quantities.
- **Perfect glazed cut:** Complete collection of more than 50 discs with high-precision blade sharpening.



SAVE TIME

Save several hours of manual labour per day:

- Cutter function: up to **7 kg of minced meat in 2 minutes.**
- Vegetable preparation function: up to **12 kg of grated carrots in 3 minutes.**



HEAVY-DUTY

Longer life:

- **Stainless steel** cutter bowl.
- **Metal** motor housing and vegetable cutting accessory.
- **Heavy-duty** powerful induction motor.

*Musculoskeletal disorders

VEGETABLE PREPARATION function

The widest available variety of cuts: 50 stainless-steel, precision-sharpened discs for flawless cutting quality.



EXPERT disc range

Slicers : 1 mm to 14 mm

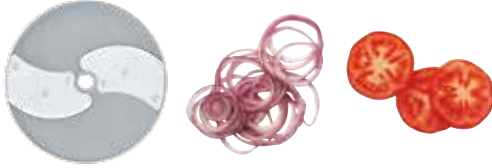

	Ref.		Ref.
0,6 mm	28166W	6 mm (1/4")	28196W
0,8 mm	28069W	8 mm (5/16")	28066W
1 mm (3/64")	28062W	10 mm (3/8")	28067W
2 mm (5/64")	28063W	14 mm (9/16")	28068W
3 mm (1/8")	28064W	Cooked potatoes 4 mm (5/32")	27244W
4 mm (5/32")	28004W	Cooked potatoes 6 mm (1/4")	27245W
5 mm (3/16")	28065W		

Graters : 1,5 mm to 9 mm

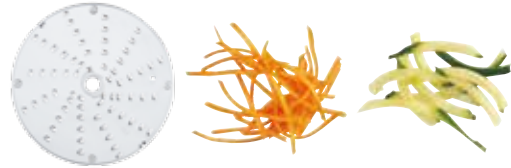

	Ref.		Ref.
1,5 mm (1/16")	28056W	9 mm (1/32")	28060W
2 mm (5/64")	28057W	Parmesan cheese	28061W
3 mm (1/8")	28058W	Röstis potatoes	27164W
4 mm (5/32")	28073W	Raw potatoes	27219W
5 mm (3/16")	28059W	1 mm Horseradish paste	28055W
7 mm (9/32")	28016W		

Ripple-cut : 2 mm to 5 mm



	Ref.		Ref.
2 mm (5/64")	27068W	5 mm (3/16")	27070W
3 mm (1/8")	27069W		

French fries : 8x8 mm to 10x16 mm



	Ref.		Ref.
8 x 8 mm (5/16"x5/16")	28134W	10 x 10 mm (3/8"x 3/8")	28135W
8 x 16 mm (5/16"x5/8")	28159W	10 x 16 mm (3/8"x 5/8")	28158W

Julienne : 1x8 mm to 8x8 mm



	Ref.		Ref.
1 x 8 mm tagliatelle (3/64"x5/16")	28172W	2 x 2 mm (5/64")	28051W
1 x 26 mm onion/cabbage (3/64"x1")	28153W	2,5 x 2,5 mm (1/10")	28195W
2 x 4 mm (5/64"x5/32")	27072W	3 x 3 mm (1/8")	28101W
2 x 6 mm (5/64"x1/4)	27066W	4 x 4 mm (5/32")	28052W
2 x 8 mm (5/64"x5/16")	27067W	6 x 6 mm (1/4")	28053W
2 x 10 mm tagliatelle (5/64"x3/8")	28173W	8 x 8 mm (5/16")	28054W

Dicers : 5x5x5 mm to 50x70x25 mm

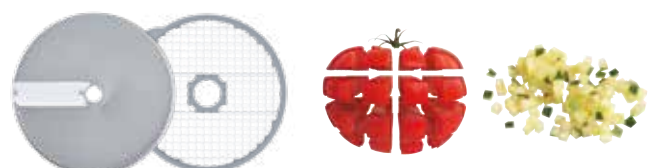

	Ref.		Ref.
5 x 5 x 5 mm (3/16")	28110W	14 x 14 x 10 mm (9/16"x3/8")	28179W
8 x 8 x 8 mm (5/16")	28111W	14 x 14 x 14 mm (9/16")	28113W
10 x 10 x 10 mm (3/8")	28112W	20 x 20 x 20 mm (25/32")	28114W
12 x 12 x 12 mm (15/32")	28197W	25 x 25 x 25 mm (1")	28115W
14 x 14 x 5 mm (9/16"xx3/16")	28181W	50 x 70 x 25 mm (1")	28180W

PUREE function

Can produce up to 10 kg of fresh mashed potato in just 2 minutes.



POTATO RICER ATTACHMENT



Option :
R502 / R502VV /
R702 / R702VV

paddle
+
3-mm puréeing grid
+
Ejector disc Specially
intended for mash and
purées.

POTATO RICER EQUIPMENT



Option :
R752VV

paddle
+
3-mm puréeing grid
+
Ejector disc Specially
intended for mash and
purées

Combination Processors: bowl cutter and vegetable prep

The Product Advantages:

2 Machines in 1 !

- A cutter bowl and a vegetable preparation attachment on the same motor base.

High performance:

- The pulse function keeps you in command and allows you to maintain the precision cut that you require. Patented blade knife, an exclusive Robot-Coupe feature, gives perfect result for small or large quantities when using the cutter attachment.

Robustness:

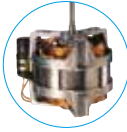

- Heavy duty industrial induction motor to stand up to intensive use.
- Motor mounted on ball bearings for silent operation, completely vibration-free.
- Motor directly engaged with accessory:
 - higher output
 - no complex drive system.
- Maintenance-free: no wearing parts (no carbon).
- Stainless steel motor shaft.

Timer:

- Less effort, greater precision and more regular results no matter what the recipe.

Wide range of cut:

- Complete collection of 50 discs for all your requirements such as slicing, julienne, ripple cutting, grating, macedoine or French fries.



Number of covers:

30 to 400.



Users:

Restaurants - Caterers



In brief:

High performance and robust, these machines will be a proud investment, saving you time and money.



CE mark	Characteristics						
	Motor base	Cutter attachment	Vegetable preparation attachment	R-Mix Function	Power (HP)	Voltage* (Amp.)	Intensity (Amp.)
R502	3 phase 900 - 1800 rpm	5,9 litres Stainless Steel	Metallic Selection of 50 discs	NO	1.2	208-240V/ 60/3 Hz	3.8 & 3.6
R502VV	Single-phase 300 to 3500 rpm	5,9 litres Stainless Steel	Metallic Selection of 50 discs	60 to 500 rpm	2	120V/ 60/1 Hz	5.8
R702	3 phase 900 - 1800 rpm	7,5 litres Stainless Steel	Metallic Selection of 50 discs	NO	2.4	208-240V/ 60/3 Hz	3.8 & 3.6
R702VV	Three-phase 300 to 3500 rpm	7,5 litres Stainless Steel	Metallic Selection of 50 discs	60 to 500 rpm	2	120V/ 60/1 Hz	5.8
R752VV	Single-phase 300 to 3500 rpm	7,5 litres Stainless Steel	Metallic Selection of 50 discs	60 to 500 rpm	2	120V/ 60/1 Hz	5.8

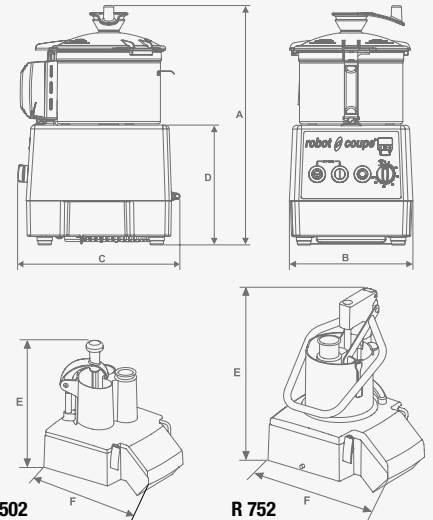

	Dimensions (in inches)						Weight (Lbs)	
	A	B	C	D	E	F	Net	Gross
R502 / R502VV	21 1/4	10 15/16	14 3/8	10 5/8	15 13/16	14 7/8	64 / 66	73 / 77
R702 / R702VV	22 7/16	10 15/16	14 3/8	10 5/8	15 13/16	14 7/8	70.5 / 73	79.5 / 81.5
R752VV	22 7/16	10 15/16	14 3/8	10 5/8	17 7/16	14 7/8	73	84

robot coupe®

Robot Coupe U.S.A., Inc.

264 South Perkins Street,
Ridgeland, MS 39157
Phone: 1-800-824-1646

email: info@robotcoupeusa.com

www.robot-coupe.com

DISTRIBUTOR



We reserve the right to alter at any time without notice the technical specifications of this appliance. None of the information contained in this document is of a contractual nature. Modifications may be made at any time.

© All rights reserved for all countries by: ROBOT COUPE S.N.C.