

robot coupe®

NEW
Register
your product
on line



- R 301 Dice
- R 301 Dice Ultra

Robot Coupe U.S.A., Inc.

264 South Perkins, Ridgeland, MS 39157 - Phone : 800/824-1646 - 601/898-8411
email: info@robotcoupeusa.com - website: www.robot-coupe.com

IMPORTANT WARNING



WARNING

KEEP THESE INSTRUCTIONS IN A SAFE PLACE

WARNING: In order to limit accidents such as electric shocks or personal injury, and in order to limit material damage due to misuse of the appliance, please read these instructions carefully and follow them strictly. Reading the operating instructions will help you get to know your appliance and enable you to use the equipment correctly. Please read these instructions in their entirety and make sure that anyone else who may use the appliance also reads them beforehand. Our equipment is designed for professional use and must not be used by children under any circumstances.

UNPACKING

- Carefully remove the equipment from the packaging and take out all the boxes or packets containing attachments or specific items.
- **WARNING:** some of the tools are very sharp e.g. blades, discs... etc..
- Store manuals, tools and spare parts in a safe place available to the users of the machine

INSTALLATION

This machine must be operated on a clean sturdy counter or table. Keep the area around and under the machine clear to allow air circulation. Otherwise the motor can overheat. All four feet must be in place.

CONNECTION

- Always check that your power supply corresponds to that indicated on the identification plate on the motor unit and that it can withstand the amperage.
- The unit must always be connected to a grounded outlet with Ground Fault Circuit Interrupter (GFCI) protection device.
- Always check that the motor shaft rotates in counter clockwise direction before the blades are installed.

HANDLING

- Always take care when handling the blades, as they are extremely sharp.
- Wear cut-proof gloves when handling the blades.

USE

- The machine must not be modified in any way from its original configuration.
- **Never tamper with, or defeat the purpose of the locking and safety systems.**
- Do not put nonfood objects in the bowl.
- Do not leave the machine running unattended.
- The machine must be operated and stored in a location not subject to water drips or spray or explosive vapors.
- Should the machine malfunction or should any part be damaged, it must not be operated until it is repaired by a qualified technician using only genuine Robot Coupe repair parts.

Failure to follow these operating instructions or attempts to operate the machine outside its design limits may create a hazardous condition that could damage the machine and/or injure users. Special attention should be given to the use of the operation controls and safety features.

- The unit is equipped with a thermal overload circuit-breaker. If the unit overheats due to an overload condition, it will automatically shut off. After cooling a few minutes the thermal overload circuit-breaker may be reset. Press the reset button located on the bottom left front of the unit.
- Operating times of 5 minutes or longer can cause processed food to increase to temperatures above 125° F (52° C).
- Maximum fill level is $\frac{2}{3}$ full, less if the product is very dense or sticky.

CLEANING

- As a precaution, always unplug your appliance before cleaning it.
- Always clean the appliance and its attachments at the end of each cycle.
- Never immerse the motor base in water.
- For parts made from aluminum, use metal safe detergents intended for aluminum.
- Caustic detergents used in automatic dishwashers quickly degrade plastic parts. Hand wash plastic parts if possible.
- Robot Coupe can in no way be held responsible for the user's failure to follow the basic rules of cleaning and hygiene.

MAINTENANCE

- Do not open the motor housing. There are no user serviceable components inside the electrical housing. Refer control component repairs to qualified technicians.
- Replace seals every 3 to 6 months. Lubricate with food safe grease.
- It is particularly important to maintain and check the attachments since certain ingredients contain corrosive agents, e.g. citric acid.
- Never operate the appliance if the power cord or plug has been damaged or if the appliance fails to work properly or has been damaged in any way.
- If the machine malfunctions in any way discard any food being processed and refer service to qualified maintenance technicians.

@ www.robotcoupeusa.com

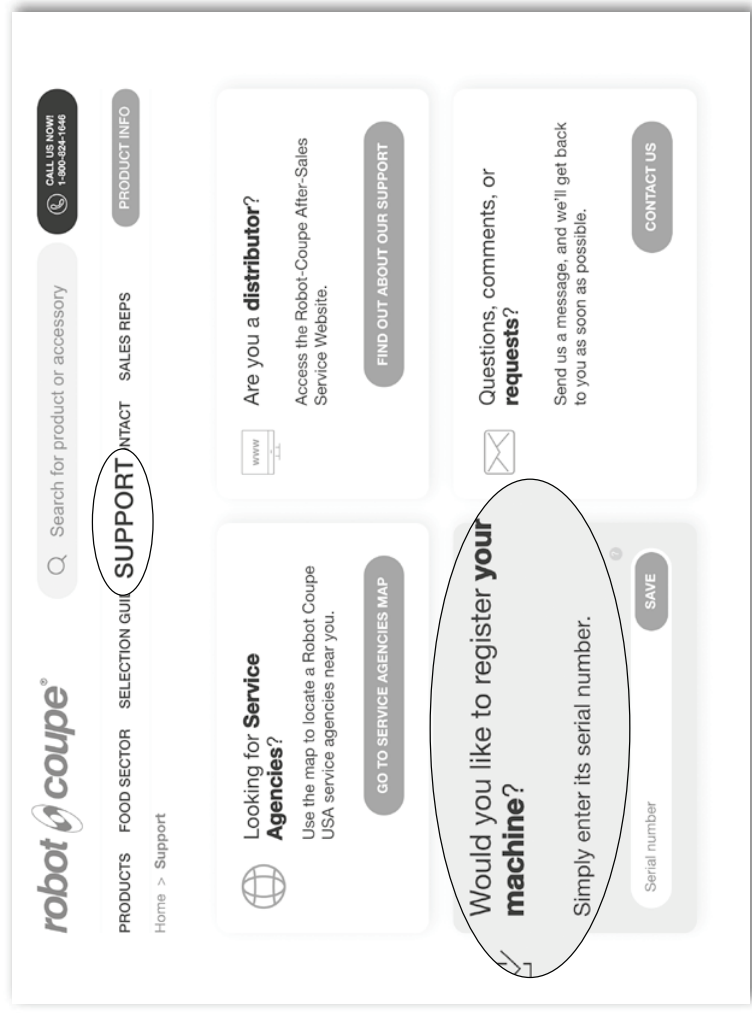

Register your product online

We reserve the right to alter at any time without notice the technical specifications of this appliance.
None of the information contained in this document is of a contractual nature. Modifications may be made at any time.
© All rights reserved for all countries by: ROBOT-COUPÉ S.N.C.

SUMMARY

WARRANTY

IMPORTANT WARNING

INTRODUCTION TO YOUR NEW R 301 Dice • R 301 Dice Ultra CUTTER BOWL / VEGETABLE PREPARATION ATTACHMENT

SWITCHING ON THE MACHINE

- Advice on electrical connections
- Control panel

ASSEMBLY

- Cutter bowl attachment
- Vegetable preparation attachment

OPERATING INSTRUCTIONS

- Cutter bowl attachment
- Vegetable preparation attachment

ACCESSORIES

- Coarse serrated blade
- Fine serrated blade

CLEANING

- Motor base
- Attachments
- Blade and cutting plates

MAINTENANCE

- Motor seal
- Blade
- Bowl locking washer

TECHNICAL SPECIFICATIONS

- Weight
- Dimensions
- Working height
- Noise level

SAFETY

SERVICE

ELECTRICAL AND WIRING DIAGRAM

ROBOT COUPE U.S.A., INC. ONE YEAR LIMITED COMMERCIAL WARRANTY

YOUR NEW ROBOT-COUCHE COMMERCIAL PRODUCT IS WARRANTED TO THE ORIGINAL PURCHASER FOR A PERIOD OF ONE YEAR FROM THE DATE OF PURCHASE.

This LIMITED COMMERCIAL WARRANTY is against defects in the material and / or workmanship, and includes labor for replacement of defective parts, provided repairs are performed by an authorized service agency (see attached list). The CUSTOMER must inform the Service Agency of the possibility of warranty coverage and provide a copy of the dated sales or delivery receipt BEFORE WARRANTY REPAIRS ARE BEGUN. All parts or accessories replaced under warranty must be returned to the Service Agency. The warranty for work done or parts replaced under warranty expires at the end of the original warranty period.

Replacement parts and accessories are warranted for ninety (90) days from the date of purchase when purchased separately and will be verified by dated sales receipt OR packing slip which list that item.

All Robot-Coupe Products are considered commercial use only.

THE FOLLOWING ARE NOT COVERED UNDER WARRANTY:

- 1 - Damage caused by abuse, misuse, dropping, or other similar incidental damage caused by or as result of failure to follow installation, assembly, operating, cleaning, user maintenance or storage instructions, including failure to verify and correct rotation of three phase motors.
- 2 - Labor to sharpen and/or parts to replace knife assemblies or blades which have become dull, chipped, or worn due to normal use.
- 3 - Material or labor to renew or repair scratched, stained, chipped, dented, or discolored surfaces, blades, knives, attachments, or accessories.
- 4 - Transportation charges to or from an authorized service agency for repairs of a machine designated as "CARRY IN SERVICE" (Table Top Models).
- 5 - Labor charges to install or test attachments or accessories (i.e. bowls, cutting plates, blades, attachments) which are replaced for any reason.
- 6 - Charges to change Direction-of-Rotation of Three Phase electric motors (INSTALLER IS RESPONSIBLE). All Robot Coupe products must operate counter-clock-wise.
- 7 - SHIPPING DAMAGE IS NOT COVERED BY WARRANTY. Visible and hidden damages are the responsibility of the freight carrier. The consignee must file a damage claim promptly against the carrier, or upon discovery in the case of hidden damage.
- 8 - Any ROBOT-COUCHE COMMERCIAL PRODUCT used in an Industrial application.

Commercial equipment use is defined as but not limited to the preparation of food substance within the confines of a restaurant/facility, that is sold and consumed within said restaurant/facility.

Industrial equipment use is defined as but not limited to the manufacturing of food substance in large batch quantities. The processed food is then packaged and sold off site and or to a distributor for resale off site.

KEEP ALL ORIGINAL CONTAINERS AND PACKING MATERIALS FOR CARRIER INSPECTION

All Robot-Coupe equipment should be operated in an ambient room temperature of 60 degrees (F) or higher.

Robot-Coupe U.S.A., Inc., Robot-Coupe S.A., or any of their affiliates, distributors, officers, directors, agents, employees or insurers will not be obligated for consequential or other damages, losses, or expenses in connection with or by reason of the use of or the inability to use the machine for any purpose.

THIS WARRANTY IS GIVEN EXPRESSLY AND IN LIEU OF ALL OTHER WARRANTIES EXPRESSED OR IMPLIED, FOR MERCHANTABILITY AND FOR FITNESS TOWARD A PARTICULAR PURPOSE AND CONSTITUTES THE ONLY WARRANTY MADE BY ROBOT-COUCHE, U.S.A., Inc.

IMPORTANT WARNING



WARNING: In order to limit accidents such as electric shocks or personal injury, and in order to limit material damage due to misuse of the appliance, please read these instructions carefully and follow them strictly. Reading the operating instructions will help you get to know your appliance and enable you to use the equipment correctly. Please read these instructions in their entirety and make sure that anyone else who may use the appliance also reads them beforehand. Our equipment is designed for professional use and must not be used by children under any circumstances.

UNPACKING

- Carefully remove the equipment from the packaging and take out all the boxes or packets containing attachments or specific items.
- **WARNING** - some of the tools are very sharp e.g. blade, discs... etc.

INSTALLATION

- We recommend that you install your machine on a stable solid base at a comfortable working height.

CONNECTION

- Always check that your mains supply corresponds to that indicated on the identification plate on the motor unit and that it can withstand the amperage.
- The machine must be earthed.

HANDLING

- Always take care when handling the blades or discs - they are very sharp.

ASSEMBLY PROCEDURES

- Follow the various assembly procedures carefully (see page 6) and make sure that all the attachments are correctly positioned.

USE

- Do not open the feed lead / attachment until the motor has come to a complete stop.
- Never tamper with, or defeat the purpose of the locking and safety systems.
- Do not put nonfood objects in the bowl or vegetable prep openings.
- Always use the food pushers to push the product into the vegetable preparation attachment openings.
- Do not leave the machine running unattended.

CLEANING

- As a precaution, always unplug your appliance before cleaning it.
- Always clean the appliance and its attachments at the end of each cycle.
- Never place the motor unit in water.
- For parts made of aluminum alloys, use cleaning fluids suitable for aluminum.

- For plastic parts , do not use detergents that are too alkaline (i.e., containing too much caustic soda or ammonia...)
- Robot-Coupe can in no way be held responsible for the user's failure to follow the basic rules of cleaning and hygiene.

MAINTENANCE

- Before opening the motor housing, it is absolutely vital to unplugging the appliance.
- Check the seals and washers regularly and ensure that the safety devices are in good working order.
- It is particularly important to maintain and check the attachments since certain ingredients contain corrosive agents e.g. citric acid.
- **NOTICE:** Never operate the appliance if the power cord or plug has been damaged.
- If the machine fails to operate as described in this manual, or if the machine malfunctions in any way, remove the machine from use and have it serviced. Additionally, discard all food processed at the time of the malfunction.
- Contact your local Authorized Service Agency if something appears to be wrong.

INTRODUCTION TO YOUR NEW R 301 Dice • R 301 Dice Ultra CUTTER BOWL / VEGETABLE PREPARATION ATTACHMENT

The **R 301 Dice / R 301 Dice Ultra** is a versatile machine designed to meet your professional needs. It can perform a number of tasks, as well as save much in time and labor.

This food processor consists of a bowl assembly and vegetable preparation attachment. The 3.7 quart bowl is used for chopping, grinding, pureeing, blending, mixing, and kneading of ingredients required in most every recipe. A wide range of cutting plates are available for use with the vegetable preparation attachment. Cutting plates are available for slicing, waved slicing, grating, pulping, and julienne.

Its numerous functions will open the door to a whole new culinary world.

Thanks to its simple design, all components requiring frequent handling for maintenance or cleaning can be easily assembled or removed.

All users should read this operation manual before operating the machine.

SWITCHING ON THE MACHINE

• ADVICE ON ELECTRICAL CONNECTIONS

All users should read the manual before operating the machine.

Before connecting, check that your power supply corresponds to that indicated on the machine's identification plate.

WARNING

This appliance must be plugged into an earthed socket (risk of electrocution).

• CONTROL PANEL

R 301 Dice - R 301 Dice Ultra

Red knob	=	Off switch
Green knob	=	On switch
Black knob	=	Pulse control
1 speed		1 725 rpm.

ASSEMBLY

• CUTTER BOWL ATTACHMENT

1. With the motor base facing you, place the bowl onto the motor base with the magnetic bar/handle toward the front. Turn the bowl just off-center and to the left as you lower it onto the base.



2. Then, turn it back to the right. The magnet bar/handle should come to a stop at the front of the motor base. The bowl, when properly assembled should be just off and level with the top surface of the motor base.



3. Place the blade onto the motor shaft. Rotate the blade until it drops into place. The bottom blade should be level with and just off the bottom of the bowl.



4. Note the plastic tab on the bowl lid. Place the lid on the bowl with the tab turned to the front and slightly to the left of the bowl handle; then, turn the lid back to the right until it comes to a stop with the tab over the bowl handle.



The device is now ready for use.

• VEGETABLE PREPARATION ATTACHMENT

The vegetable preparation attachment consists of two detachable parts : the continuous feed attachment and the continuous feed lead.

1. With the motor base facing you, fit the continuous feed attachment onto the motor base; the exit chute should be on your right.



2. Turn the attachment back to the right until it comes to a stop, and is aligned with the top of the motor base.



3. Place the 4-wave green plastic ejection disc on the motor shaft and check that it is correctly positioned in the bowl-base.

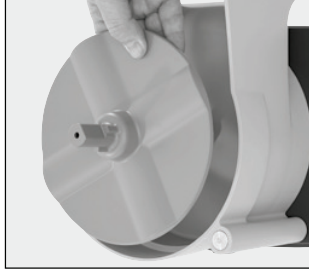

4. Place the cutting plate of your choice onto the discharge chute. It may be necessary to rotate the plate until it drops fully onto the discharge plate.

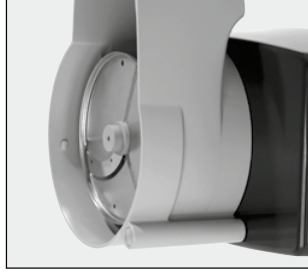

4. If you have chosen the dicing combination: i.e. a grid and a specific slicing disc.

Only the specific 8 mm, 10 mm and 12 mm slicing plates can be fitted with a dicing grid.

4.a Position the dicing grid in the vegetable preparation bowl.



4.b Next fit the appropriate slicing disc and screw the slicer on the motor shaft with the butterfly nut.

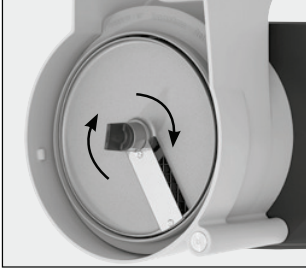

• INSTALLING THE FRENCH FRY GRID:

Specially designed slicing plates and matching grids have been developed for making French fries.

Two sizes are available: 8 x 8 mm and 10 x 10 mm.



WARNING: DICING GRID



SLICING DISC



DICING GRID



**4-WAVE EJECTION DISC
REF.: 104964S**

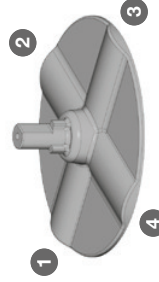

The full dicing grid is only compatible with ejection disc **104964S**.
If your machine is not equipped with this ejection disc, **don't forget to order one.**

With the discharge plate in place on the motor shaft, place the French fry grid into the continuous feed attachment with the vertical blades aligned toward the discharge chute. **If the grid is not in the correct position, jamming and motor damage may occur.**

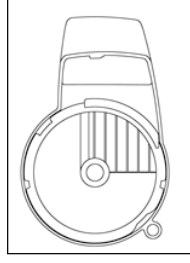

Place the matching slicing plate onto the discharge plate. You may need to rotate the plate a bit until it drops into place on the discharge plate. Tighten the plate-securing knob by turning it clockwise.



5. Place the continuous feed lead onto the continuous feed attachment, and rotate it back to the right until it is aligned with the continuous feed attachment.

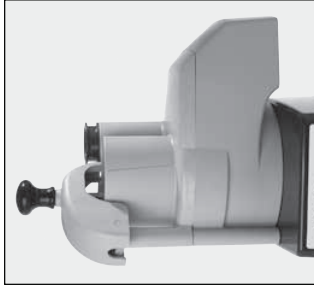
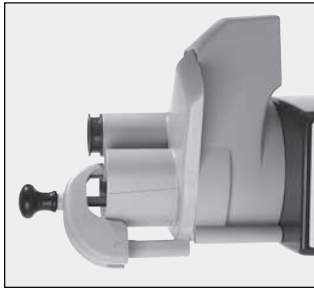

OPERATING INSTRUCTIONS

THE UNIT SHOULD BE OFF EXCEPT WHEN PROCESSING IS UNDERWAY

It is recommended that the machine be operated on a 50% duty cycle. This is easily accomplished since the preparation time (cleaning, coring, peeling, and loading) takes longer than the processing time. This will yield the longest life for your machine.

• CUTTER BOWL ATTACHMENT

The cutter bowl is used for grinding, kneading, pureeing, blending, mixing, and emulsifying. Before placing the product in the bowl some products such as meats and cheeses should be pre-cut into 1-2 inch portions. When filling the bowl, allow space above the product for circulation.

There are two ways to run your machine: chopping, using a quick start/stop action with the pulse button or running continuously for a fine chop or puree. To obtain a uniform chop of products such as meats and cheeses, begin with a uniformly portioned product. Pulse the machine until the desired result is reached. Then, if a puree or fine chop is desired, press the on button, and allow the machine to run until the product is the right consistency.

USES	Max processing quantity (in pounds)	Processing time (in min)
CHOP		
• MEAT		
Hamburgers / steak tartare	1 ¾	3
Sausage meat / tomatoes	2 ¼	3
Terrine / pâté	2 ¼	4
• FISH		
Brandade	2 ¼	5
Terrines	2 ¼	5
• VEGETABLES		
Garlic / parsley / onion / shallots	½ - 1	3
Soup / purées	2 ¼	4
• FRUIT		
Compotes / purées	2 ¼	4
EMULSIFY		
Mayonnaise / aïoli / remoulade sauce	2 ¼	3
Béarnaise / Hollandaise	2 ¼	5
Snail or salmon butter	2 ¼	4
KNEAD		
Shortcrust pastry / shortbread	4 ½	4
Flaky pastry	4 ½	4
Pizza dough	4 ½	4
GRIND		
Dried fruit	1	4
Ice	1	4
Breadcrumbs	1	4

• VEGETABLE PREPARATION ATTACHMENT

The vegetable preparation attachment is used for slicing, grating, waved slicing, julienne, and pulping.

The vegetable preparation attachment consists of two feed openings :

- **one large feed opening** for cutting vegetables such as cabbage, celeriac, etc.
- **a cylindrical feed opening** for long vegetables and high-precision cutting.

For optimum cutting, use this section as a guide.

Do not attempt to run frozen products through the cutting plates.

Do not put anything other than food products into the feed openings.

Do not remove attachments while the motor is running.







Do not apply excess pressure to the food pushers: This can cause damage to the motor and other parts.

HOW TO USE THE LARGE FEED OPENING

Raise the pusher handle, and fill the opening with the product. If the opening is overfilled the machine will not operate. Lower the pusher, and press the on button. The pusher must be in the feed opening for the machine to operate. Apply steady but moderate pressure to the pusher until the pusher has come to a stop. **If the discharge plate is not in the machine, the product will not come out from the exit chute.**

HOW TO USE THE CYLINDRICAL SMALL OPENING

Remove the small pusher from the feed opening. Fill the opening with product. Hold the pusher in one hand, and press the on button with the other. Apply steady but moderate pressure with the pusher until the pusher stops. **If the discharge plate is not in the machine, the product will not come out from the exit chute.**

SLICERS	
$\frac{3}{16}$	carrot / cabbage / cucumber / onion / potato / leek
$\frac{5}{16}$ - $\frac{1}{8}$	lemon / carrot / mushroom / cabbage / potato / cucumber / zucchini / onion / leek / bell pepper
$\frac{5}{32}$ - $\frac{3}{16}$	eggplant / beet root / carrot / mushroom / cucumber / bell pepper / radish / lettuce / potato / leek / tomato
$\frac{1}{4}$	eggplant / beet root / carrot / mushroom / cucumber / bell pepper / radish / lettuce / potato / leek / tomato
RIPPLE CUT SLICERS	
$\frac{5}{16}$	beet root / potato
GRATERS	
$\frac{3}{16}$	celeriac / cheese $\frac{3}{8}$ cabbage / cheese
$\frac{5}{16}$	carrot / celeriac / cheese Parmesan cheese
$\frac{3}{8}$	carrot $\frac{5}{32}$ Radish 0.7 mm
$\frac{1}{4}$	cabbage / cheese $\frac{3}{16}$ Radish 1 mm
JULIENNE	
$\frac{5}{16}$ x $\frac{5}{16}$	carrot / celeriac / potato
$\frac{5}{16}$ x $\frac{5}{32}$	carrot / beet root / zucchini / potato
$\frac{5}{16}$ x $\frac{1}{4}$	carrot / beet root / zucchini / potato
$\frac{5}{32}$ x $\frac{5}{32}$	eggplant / beet root / zucchini / potato
$\frac{1}{4}$ x $\frac{1}{4}$	eggplant / beet root / celeriac / zucchini / potato
$\frac{5}{16}$ x $\frac{5}{16}$	celeriac / potato
DICE	
$\frac{5}{16}$ x $\frac{5}{16}$	potato / carrot / zucchini / beet root / turnip
$\frac{3}{8}$ x $\frac{3}{8}$	potato / carrot / zucchini / beet root / turnip
$\frac{15}{32}$ x $\frac{15}{32}$	potato / carrot / zucchini / beet root / turnip
FRENCH FRIES	
$\frac{5}{16}$ x $\frac{5}{16}$	potato
$\frac{3}{8}$ x $\frac{3}{8}$	potato

ACCESSORIES



• A **coarse serrated blade** is available as an option and is mainly intended for kneading and grinding.



• A **fine serrated blade** is available mainly for use in chopping parsley. The blade edge is longer lasting than the smooth blade but cannot be sharpened.

We advise you to use this blade mainly to chop parsley.

CLEANING



WARNING

As a precaution, always unplug your appliance before cleaning it (risk of electric shock).

• MOTOR BASE

Never immerse the motor base in water. Clean using a damp cloth or sponge.

• ATTACHMENTS:

Remove all attachments before cleaning. The bowl and continuous feed attachments should be cleaned per the following instructions or as required by local health department regulations.

The bowl, blade, lid, continuous feed attachment, continuous feed lead, pushers, and plates are dishwasher safe. All of the attachments listed above can be washed in a dish machine or three-tank system pot sink. Pre-rinse the attachments before

washing to remove any bulk food on the parts. A stiff bristle brush or power sprayer faucet attachment is effective in knocking the food out of the crevices as a pre-rinse procedure. The washer should have an industry standard wash, rinse, and sanitization cycle. Allow the parts to air dry after sanitizing and before reassembly.

NOTE : The high temperatures of dish machines will tend to shorten the life of the plastic and rubber parts. Hand washing using a three-pot sink will provide for the longest life of these parts.

Wear cut-resistant gloves when cleaning the blade and plates.

Inspect the area on the outside of the bowl and feed attachment around the handle and magnetic rod to ensure they are clean. Use a brush on these areas if necessary.

MOTOR BASE : Cleaning of the motor base assembly must be done with care.

First unplug the unit. A sponging with a cloth lightly dampened (not dripping) in a mild detergent is acceptable, making sure the water is not permitted to penetrate the shaft seal or around the switches.

Clean around the shaft seal with a small brush, taking care to remove all food. Do not forget to clean the motor shaft. Rinse the motor base first using a cloth lightly dampened (not dripping) with water, then with a sanitizing solution. Dry the machine with a soft cloth removing all liquids from seal areas.

• BLADE AND CUTTING PLATES

Blades should be kept sharp. It is not necessary to have a razor edge. However, they will need sharpening periodically. Replacement of the dull blades or plates is recommended.



IMPORTANT

Check that your detergent is suitable for cleaning plastic parts. Some washing agents are too alkaline (e.g. high levels of caustic soda or ammonia) and totally incompatible with certain types of plastic, causing them to deteriorate rapidly.

MAINTENANCE

• MOTOR SEAL

An examination should be made periodically to assure that a seal against liquids is being maintained around the motor shaft. The seal can and should be replaced whenever wear or erosion is noted or minimally once every three to six months. It is recommended that the seal be replaced by an authorized repair agency.

• BLADE

Blades should be kept sharp. It is not necessary to have a razor edge. However, they will need sharpening periodically. Replacement of the dull blades or plates is recommended.

• BOWL LOCKING WASHER

The bowl locking washer is located below the bowl and holds the bowl in place. If it becomes worn, it needs to be replaced.

TECHNICAL SPECIFICATIONS

	Net	Gross
R 301 Dice (without disc)	28.6	35.2
R 301 Dice Ultra (without disc)	31	37.5

• DIMENSIONS (in inches)

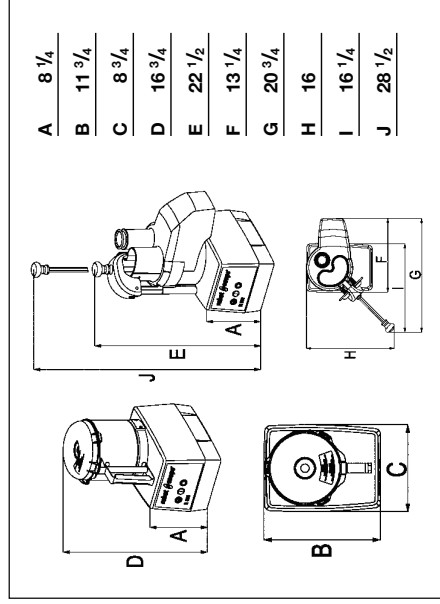

• WORKING HEIGHT

We recommend that you position the food processor on a stable worktop so that the upper edge of the large feed hopper is at a height of between 47 and 51 inches.

• NOISE LEVEL

The equivalent continuous sound level when the food processor is operating on no-load is less than 70 dB (A).

a complete stop and the preparation has stopped moving.

This will ensure the lid's seal remains watertight, thus eliminating any risk of liquid preparations spattering. Risk of burns from hot preparations.

To resume operating your machine, simply re-lock the lid into place and press the "Start" (green) or "Pulse" (black) button.

These models are equipped with a **thermal failsafe** that automatically stops the motor if it is overloaded.

In this case, wait for the machine to cool down before turning it on again.



REMEMBER

Never try to override or defeat the purpose of, the locking and safety systems.

Never put nonfood objects into the machine openings.

Only use the food pushers to force the food into the machine.

Do not overload the appliance.

Never leave the machine running unattended.

Never switch the appliance on when it is empty.

SERVICE

See warranty first then;

Should your unit require service, check with your distributor to see where local service is available.

If not or if you wish your unit to be serviced at the factory, call for return instructions and ship the unit prepaid to our factory address.

PH : 1-800-824-1646

Robot-Coupe USA, Inc

Service Department Repair

264 South Perkins Street

Ridgeland, MS 39157

For service in Canada contact the Robot-Coupe USA factory for repair instructions.



WARNING

The blades and cutting plates are extremely sharp. Handle with care.

The machine is equipped with a safety system and motor brake. It cannot be turned on if the bowl and lid are not locked into place on the motor base.

To stop the motor, always use the red "Stop" button. In addition, due to the food's potential inertia depending on its nature, quantity and viscosity, combined with the associated risk of spattering, never open the lid before the motor has come to

robot  **coupe**[®]

**ELECTRICAL AND
WIRING DIAGRAMS**

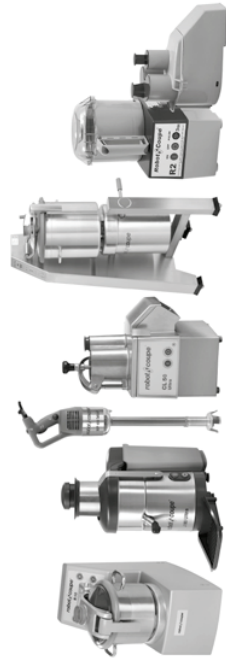

robot coupe®

Robot Coupe U.S.A., Inc.,

Phone: 800/824-1646 - 601/898-8411

264 South Perkins St., Ridgeland, MS 39157

e-mail: info@robotcoupeusa.com

website: www.robot-coupe.com

