

robot coupe[®]

 **VERTICAL CUTTER MIXERS**
R23T - R30T - R45T - R60T



**INSTITUTIONS - DELICATESSENS - CATERERS -
RESTAURANTS - CONFECTIONERS - LABORATORIES**

▶ R23T - R30T - R45T - R60T

For
MAXIMUM OUTPUT
in a
MINIMUM
amount of
TIME

HIGH PERFORMANCE



PRECISION



COMFORT



ERGONOMICS



RUGGED AND POWERFUL

Extremely powerful **induction motor** designed to withstand intensive use, thus ensuring a high level of reliability and a longer lifespan.

100% stainless-steel construction and three sturdy legs for total stability.



▶ HOW TO MAKE A PIZZA WITH A VERTICAL CUTTER MIXER?



Bowl-base blade assembly with three detachable and height-adjustable blades to ensure a perfectly uniform consistency, even when processing small amounts.

Control panel designed for straightforward and reliable use. Includes a **timer** to keep track of the processing.

Pulse control for optimum cutting accuracy.

Removable, tiltable bowl with a locking lever for effortless emptying and cleaning.

Three retractable wheels, making it easier to move the machine around.

Watertight lid.

The lid and lid wiper are easily detached.



Pizza Sauce
18 Seconds



Cheese
30 Seconds



Dough Ball
45 Seconds



Minced Meat
18 Seconds

RICH AND VARIED PREPARATIONS

Our vertical cutter-mixers can meet the needs of even the most demanding professionals. They can be used in many different settings and have numerous applications via their key functions:

MINCING

Pâtés, stuffings, sausages, fish or vegetable terrines, steak or fish tartare, curry paste, moussaka, cheese for pizzas, fine herbs, onions, shallots, vegetable purées, etc.

EMULSIFYING

Sauces, fine-textured stuffings, mousses, mayonnaise, guacamole, taramasalata, tapenade, pesto, hummus, foie gras, quenelles, etc.

MIXING

Flavored butters, creamed butter, baking mixes, sweet fillings, layered terrines, cheesecake, etc.

GRINDING

Macaroon base, ground raisins, almond paste, praline, shellfish bisque, breadcrumb mixes, peanut butter, finely ground ingredients, etc.

KNEADING

Sweet or savory pastry, raised dough, biscuits, etc.



Meatballs



Hummus

ANALYTICAL LABORATORIES AND R&D:

Food and non-food.

Powder and pigment mixtures, homogenization, dispersion, dissolution, dilution, emulsification, grinding, etc.

▶ The blade assemblies

STANDARD SUPPLY

SMOOTH BLADE



Coarse chopping



Fine chopping



Sauces, emulsions

OPTIONAL EXTRA

COARSE-SERRATED BLADE



Grinding



Kneading

FINE-SERRATED BLADE

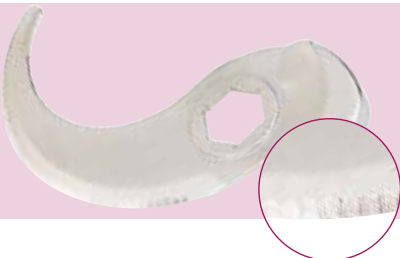

Chopping herbs



Grinding spices

We reserve the right to alter at any time without notice the technical specifications of this appliance. None of the information contained in this document is of a contractual nature. Modifications may be made at any time.
© All rights reserved for all countries by : ROBOT-COUCPE s.n.c.

▶ Which vertical cutter-mixer best meets your needs?

How many covers do you serve per day?	600 to 1200	600 to 1200	1200 +	1200 +
What maximum bowl load per batch do you require?	up to 30 lbs	up to 34 lbs	up to 50 lbs	up to 72 lbs
Coarse chopping (up to)	20 lbs	24 lbs	36 lbs	50 lbs
Emulsions (up to)	30 lbs	34 lbs	50 lbs	72 lbs
Pastry/dough* (up to)	23 lbs	28 lbs	45 lbs	60 lbs
Grinding (up to)	14 lbs	17 lbs	27 lbs	36 lbs

Here is your Cutter



R23T



R30T



R45T



R60T

* Amount of raised dough at 60% hydration



Electrical data

	Speed (rpm)	Power	Rated current (Amp)	Size of circuit breaker (Amp)	Voltage*	Stainless-steel bowl capacity
R23T	1800 - 3600	6 HP	16.0	30	208-240V/60/3	51 lbs
R30T	1800 - 3600	7 HP	18.6	40	208-240V/60/3	62 lbs
R45T	1800 - 3600	13.5 HP	27.0	60	208-240V/60/3	99 lbs
R60T	1800 - 3600	16 HP	32.5	60	208-240V/60/3	132 lbs

* Other voltages available

Dimensions (in inches)

	Dimensions (in inches)							Weight (lbs)	
	A	B	C	D	E	F	G	Net	Gross
R23T	49 ¼	12 ¾	23 ¾	23 ¼	64	31 ¼	27 ¾	223	289
R30T	49 ¼	14 ¼	23 ¾	23 ¼	64	31 ½	28 ½	223	289
R45T	55 ¼	15 ¾	23 ¾	25 ¼	71	34 ¼	30	305	364
R60T	55 ¼	17 ¾	23 ¾	25 ¼	71 ¾	34 ¼	32	331	390

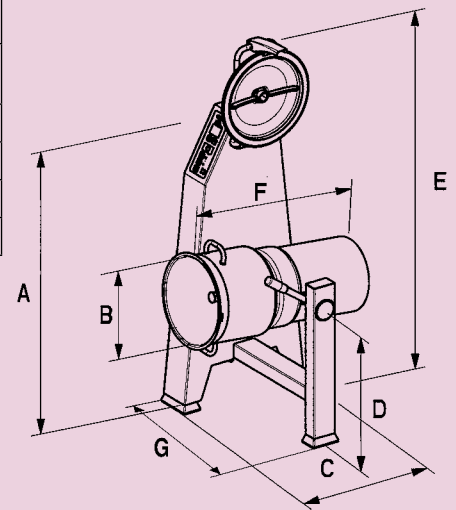

Robot Coupe U.S.A., Inc.

264 South Perkins Street,
Ridgeland, MS 39157
Phone: 1-800-824-1646

email: info@robotcoupeusa.com

www.robot-coupe.com

DISTRIBUTOR



We reserve the right to alter at any time without notice the technical specifications of this appliance. None of the information contained in this document is of a contractual nature. Modifications may be made at any time.

© All rights reserved for all countries by:
ROBOT COUCPE s.n.c.