

# IMMERSION BLENDERS



## OPTIMUM RESULTS, NO MATTER THE QUANTITY...

...no matter the receptacle, no matter the intended use, Robot-Coupe Immersion Blenders will meet all your needs!

They can mix, blend, emulsify, whip or knead your preparations in no time!

Their performance in terms of hygiene, ease of use, versatility and durability makes them the best on the market.



# IMMERSION BLENDERS

## ERGONOMICS

Ergonomic handle for greater user comfort.

## PERFORMANCE

High-power motor and increased performance to **optimise blending time**.

## LONG SERVICE LIFE

Stainless steel motor base for intensive use.

## INNOVATION



## CLEANING

**Removable stainless steel bell and blade** for easy cleaning and maintenance.

Patented Robot-Coupe system.



The MP V.V. and MP Combi models feature an **ergonomic variable speed button** for greater user comfort.

## INNOVATION



## ERGONOMICS

**New cord winding system** to make it easier to store and prevent wear and tear.

## TUBE

All stainless steel.

## NEW



## New EasyGrip removable handle.

The machine's weight is distributed better making it even easier to use!

## AFTER SALES SERVICE: DETACHABLE POWER CORD

- 1 **The patented "EasyPlug" system** means that the power cord can be easily replaced by the customer or the end-user.
- 2 **Run Indicator light** : Indicates the machine is in use.





**SOUPS**



**SAUCES**



**COULIS**



**EMULSIONS**



The emulsifying disc is available on the Mini and Micromix product lines.

# IMMERSION BLENDERS

MINI			COMPACT		LARGE				
<b>Mini MP</b> See page 126			<b>CMP</b> See page 128		<b>MP</b> See page 130				
7"	8"	10"	10"	16"	14"	18"	21"	24"	29"
240 W Mini MP 160 V.V.	270 W Mini MP 190 V.V.	290 W Mini MP 240 V.V.	310 W CMP 250 V.V.	420 W CMP 400 V.V.	660 W MP 350	720 W MP 450	840 W MP 550	920 W MP 600	1000 W MP 800
15 litres			73 litres		50 litres	100 litres	200 litres	300 litres	400 litres
Commercial foodservice			Commercial foodservice		Institutions, caterers, intensive use				
Small portions			Regular use		Large receptacles				

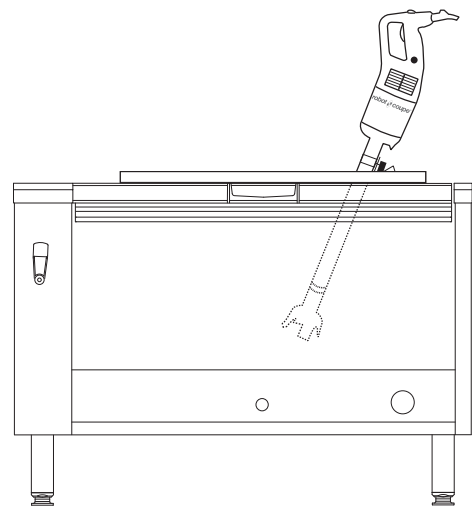
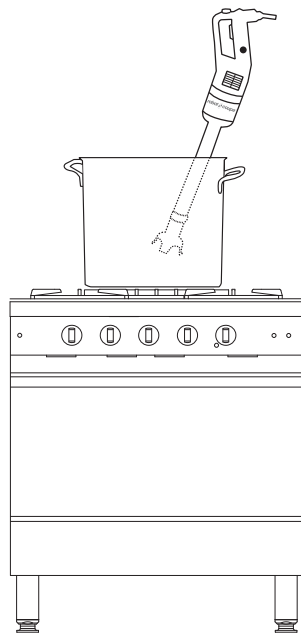
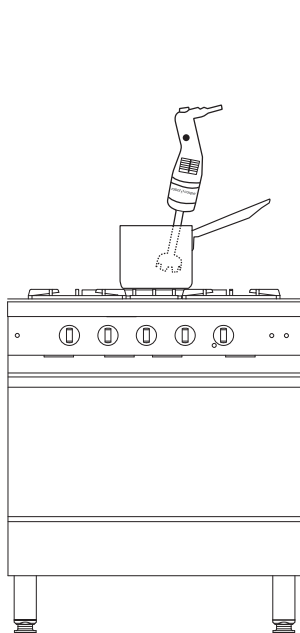

## SPECIAL FOR TILTING PAN

**MP**  
See page 134



660 W  
MP 350  
TP

1000 W  
MP 800  
TP

50 litres

100+ litres



Commercial foodservice, institutions

Special for Tilting Pan

## COMBI

**MINI MP - CMP - MP - MP FW**  
See page 136



270 W  
Mini MP  
190 Combi

290 W  
Mini MP  
240 Combi

310 W  
CMP 250  
Combi

660 W  
MP 350  
Combi

720 W  
MP 450  
Combi

720 W  
MP 450  
FW

720 W  
MP 450 XL  
FW

15 litres

50 litres

100 litres

100 litres

100 litres

Commercial foodservice

Regular use

Institutions, caterers

Intensive use

## CLEANING



Quick and easy to clean:

- 1 The stainless steel blade and bell are easy to remove.
- 2 Each machine comes with a disassembling tool.

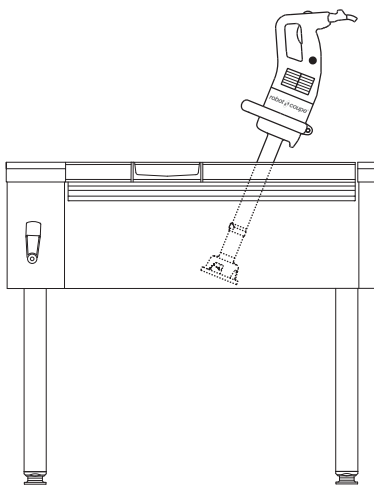

BACK TO SUMMARY



# MINI PRODUCT RANGE

**Minimum size, maximum performance!**

For sauces, emulsions and small preparations.



**VARIABLE SPEED BUTTON**

Easy to see and adjust.

**HANDLE DESIGN**

for easy grip and **effortless use.**



**Detachable stainless steel blade and shaft** for perfect sanitation.



**Blade designed for optimum blending.**



**STAINLESS STEEL MOTOR HOUSING**

To make the immersion blender last longer.



**AEROMIX**

Patented emulsifying tool designed to make instant light fluffy **emulsions** that always keep their shape on the plate.



## BLADE



## AEROMIX

For emulsions





### Mini MP 160 V.V.

### Mini MP 190 V.V.

### Mini MP 240 V.V.

Power	240 W	270 W	290 W
Voltage	Single Phase - 120 V	Single Phase - 120 V	Single Phase - 120 V
Speed	2000 to 12500 rpm	2000 to 12500 rpm	2000 to 12500 rpm
Blade, bell and shaft	7" length	8" length	10" length
Detachable stainless steel blade	✓	✓	✓
Detachable bell	No	✓	✓
Detachable tube	✓	✓	✓
Dimensions	18 1/3" x 3"	20 1/5" x 3"	22 1/3" x 3"
Weight	5 lbs	5 lbs	5 lbs
<b>Accessories</b>	Aeromix stainless steel <b>Included</b> Wall support - <b>Included</b>	Aeromix stainless steel <b>Included</b> Wall support - <b>Included</b>	Aeromix stainless steel <b>Included</b> Wall support - <b>Included</b>

Choose your model:



Mini MP 160 V.V.	Ref.	\$	Mini MP 190 V.V.	Ref.	\$	Mini MP 240 V.V.	Ref.	\$
120V/60/1	MMP160V	444	120V/60/1	MMP190V	492	120V/60/1	MMP240V	572

Choose your options:

Options	Mini MP 160 V.V.		Mini MP 190 V.V.		Mini MP 240 V.V.	
	Ref.	\$	Ref.	\$	Ref.	\$
Bell Cover assembly with removable stainless steel blade	89101	306	89053	278	89053	278
Blade assembly tool	89058	57	89058	57	89058	57
Wall rack for Immersion Blenders	89614	60	89614	60	89614	60



**Whisk function**  
**Mini MP 190 Combi**  
See page 137



**Whisk function**  
**Mini MP 240 Combi**  
See page 137



# CMP COMPACT PRODUCT RANGE

**Compact, easy-to-handle, high-performance.**  
For restaurants & cafés



### PERFORMANCE

Optimum blending for a fine textured end product in a minimum amount of time.



### LONG SERVICE LIFE

Stainless steel motor base for intensive use.

### DURABILITY

Equipped with a 3-level watertightness system.



### INNOVATION



### CLEANING

**Removable stainless steel bell and blade** for easy cleaning and maintenance.



### POWERFUL

**High-strength motor:**  
+15 % for greater efficiency.

### COMFORT

**Variable speed** for greater flexibility when making sophisticated preparations.

### INNOVATION



### ERGONOMICS

Light, compact, easy-to-handle appliance.

**The lug on the motor base** can be used to rest the mixer on the rim of a pan to make it easier to handle and remove some of the strain.

**New cord winder** to make it easier to store and prevent wear and tear.

## AFTER SALES SERVICE: DETACHABLE POWER CORD

- 1 The patented "EasyPlug" system** means that the power cord can be easily replaced by the customer or the end-user.
- 2 Run Indicator light** : Indicates the machine is in use.





## CMP 250 V.V.

Power	310 W
Voltage	Single Phase - 120 V
Speed	5000 to 10000 rpm with automatic speed regulating system
Blade, bell and shaft	10" length
Detachable stainless steel blade	✓
Detachable bell	✓
Detachable tube	No
EasyPlug	✓
Dimensions	26" x 3 9/16"
Weight	11 lbs
<b>Accessories</b>	Wall support - <b>Included</b>

Choose your model:



CMP 250 V.V.	Ref.	\$
120V/60/1	CMP250VV	<b>730</b>



## CMP 400 V.V.

Power	420 W
Voltage	Single Phase - 120 V
Speed	5000 to 10000 rpm with automatic speed regulating system
Blade, bell and shaft	16" length
Detachable stainless steel blade	✓
Detachable bell	✓
Detachable tube	No
EasyPlug	✓
Dimensions	30" x 3 9/16"
Weight	13 lbs
<b>Accessories</b>	Wall support - <b>Included</b>

CMP 400 V.V.	Ref.	\$
120V/60/1	CMP400VV	<b>961</b>

Choose your options:

Options	CMP All models	
	Ref.	\$
Bell Cover assembly with removable stainless steel blade	89678	<b>362</b>
Blade assembly tool	89662	<b>47</b>
Wall rack for Immersion Blenders	89629	<b>60</b>



**Whisk function**  
**CMP 250 Combi**  
 See page 137

# MP LARGE PRODUCT RANGE

Even better performance and ergonomics!



### ERGONOMICS

Ergonomic handle for greater convenience.



For the MP V.V. and MP Combi models, **more ergonomic variable speed button** for greater convenience.

### PERFORMANCE

High-power motor and increased performance to **optimise blending time**.



### LONG SERVICE LIFE

Stainless steel motor base for intensive use.



### ERGONOMICS

**New cord winding system** to make it easier to store and prevent wear and tear.



### TUBE

All stainless steel.



### CLEANING

**Removable stainless steel bell and blade** for easy cleaning and maintenance. Patented Robot-Coupe system.



**New EasyGrip removable handle.** The machine's weight is distributed better making it even easier to use!

## AFTER SALES SERVICE: DETACHABLE POWER CORD\*

- 1 The patented "EasyPlug" system means that the power cord can be easily replaced by the customer or the end-user.
- 2 Run Indicator light : Indicates the machine is in use.





## MP 350

## MP 450

## MP 550

Power	1 HP / 660 W	1.1 HP / 720 W	1.2 HP / 840 W
Voltage	Single Phase - 120 V	Single Phase - 120 V	Single Phase - 120 V
Speed	12000 rpm	12000 rpm	12000 rpm
Blade, bell and shaft	14" length	18" length	21" length
Detachable stainless steel blade	✓	✓	✓
Detachable bell	✓	✓	✓
Detachable tube	No	No	No
Second handle	No	No	Removable <b>EasyGrip</b> handle
Electronic Booster System (EBS)	✓	✓	✓
Dimensions	30 7/8" x 5"	34 3/4" x 5"	36 7/16" x 5"
Weight	15 lbs	15 lbs	16 lbs
<b>Accessories</b>	Wall support - <b>Included</b>	Wall support - <b>Included</b>	Wall support - <b>Included</b>

Choose your model:



MP 350	Ref.	\$
120V/60/1	MP350	<b>948</b>

MP 450	Ref.	\$
120V/60/1	MP450	<b>1 130</b>

MP 550	Ref.	\$
120V/60/1	MP550	<b>1 703</b>

Choose your options:

Options	MP 350		MP 450		MP 550	
	Ref.	\$	Ref.	\$	Ref.	\$
Bell Cover assembly with removable stainless steel blade	39335	<b>328</b>	39335	<b>328</b>	39455	<b>329</b>
Blade assembly tool	89662	<b>47</b>	89662	<b>47</b>	89662	<b>47</b>
Wall rack for Immersion Blenders	89629	<b>60</b>	89629	<b>60</b>	89629	<b>60</b>
EasyGrip removable handle	27359	<b>198</b>	27359	<b>198</b>	-	-

[BACK TO SUMMARY](#)

## IMMERSION BLENDERS



### MP 600

Power	1.5 HP / 920 W
Voltage	Single Phase - 120 V
Speed	12000 rpm
Blade, bell and shaft	24" length
Detachable stainless steel blade	✓
Detachable bell	✓
Detachable tube	No
Second handle	Removable <b>EasyGrip</b> handle
Electronic Booster System (EBS)	✓
Dimensions	38" x 5"
Weight	17 lbs
<b>Accessories</b>	Wall support - <b>Included</b>

Choose your model:



Choose your options:

MP 600	Ref.	\$
120V/60/1	MP600	<b>2 170</b>



### MP 800

Power	1.6 HP / 1000 W
Voltage	Single Phase - 120 V
Speed	12000 rpm
Blade, bell and shaft	29" length
Detachable stainless steel blade	✓
Detachable bell	✓
Detachable tube	No
Second handle	Integrated stainless steel handle
Electronic Booster System (EBS)	✓
Dimensions	44.5" x 5"
Weight	21 lbs
<b>Accessories</b>	Wall support - <b>Included</b>

MP 800	Ref.	\$
120V/60/1	MP800	<b>2 639</b>

Options	MP 600		MP 800	
	Ref.	\$	Ref.	\$
Bell cover assembly with removable stainless steel cutting blade	89241	<b>368</b>	89241	<b>368</b>
Blade assembly tool	89662	<b>47</b>	89662	<b>47</b>
Wall rack for Immersion Blenders for Non Combi Models	89629	<b>60</b>	-	-
Wall rack for Immersion Blenders	-	-	89007	<b>60</b>



## MP 350 V.V.

Power	1 H / 660 W
Voltage	Single Phase - 120 V
Speed	3000 to 10000 rpm
Blade, bell and shaft	14" length
Detachable stainless steel blade	✓
Detachable bell	✓
Detachable tube	No
Electronic Booster System (EBS)	✓
Dimensions	30 7/8" x 5"
Weight	15 lbs
<b>Accessories</b>	Wall support - <b>Included</b>

Choose your model:



Choose your options:

MP 350 V.V.	Ref.	\$
120V/60/1	MP350VW	<b>1 072</b>



## MP 450 V.V.

Power	1.1 HP / 720 W
Voltage	Single Phase - 120 V
Speed	3000 to 10000 rpm
Blade, bell and shaft	18" length
Detachable stainless steel blade	✓
Detachable bell	✓
Detachable tube	No
Electronic Booster System (EBS)	✓
Dimensions	34 3/4" x 5"
Weight	15 lbs
<b>Accessories</b>	Wall support - <b>Included</b>

MP 450 V.V.	Ref.	\$
120V/60/1	MP450VW	<b>1 228</b>

Options	MP 350 V.V.		MP 450 V.V.	
	Ref.	\$	Ref.	\$
Bell Cover assembly with removable stainless steel blade	39335	<b>328</b>	39335	<b>328</b>
Blade assembly tool	89662	<b>47</b>	89662	<b>47</b>
Wall rack for Immersion Blenders	89629	<b>60</b>	89629	<b>60</b>
EasyGrip removable handle	27359	<b>198</b>	27359	<b>198</b>

[BACK TO SUMMARY](#)

## IMMERSION BLENDERS

# SPECIAL RANGE FOR TILTING PANS

Your culinary equipment evolves, so do our Immersion Blenders. New Special MP range for Tilting Pans is perfectly suited for use with tilting pans, from the smallest to the largest.

These new shorter and easier-to-handle Robot-Coupe Immersion Blenders are #THEsolution for even more convenient and comfortable use.

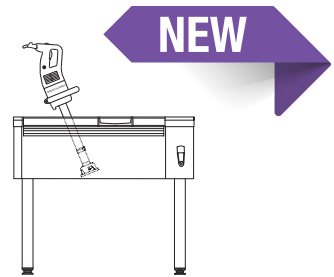

### PERFORMANCE

High-power motor to **optimise blending time.**

### LONG SERVICE LIFE

Stainless steel motor base for intensive use. Stainless steel shaft, bell and blade. Reinforced bell.

### Easy Guide

### DURABILITY

Equipped with a 6-level watertightness system.

### ERGONOMICS

**Double handle - Maximum comfort!**

Ergonomic handles for optimum user comfort, easy to use thanks to better distribution of the machine's weight!

### SHORT TUBE 14" length

Machine perfectly adapted for use in a tilting pan.

### INNOVATION

#### CLEANING

**Removable stainless steel bell and blade** for easy cleaning and maintenance. Patented Robot-Coupe system.



### EASY TO USE

Reinforced bell with a stainless steel ring that makes the appliance easy to glide in a tilting pan, with excellent manoeuvrability.

## AFTER SALES SERVICE: DETACHABLE POWER CORD

- 1 **The new patented "EasyPlug" system** means that the power cord can be easily replaced by the customer or the end-user.
- 2 **Run Indicator light** : Indicates the machine is in use.





**NEW**



Wall support

## MP 350 TP

Wattage	1 HP / 660 W
Voltage	Single Phase - 120 V
Speed	12000 rpm
Blade, bell and shaft	14" length
Detachable blade	✓
Reinforced bell.	✓
Detachable bell	✓
Detachable foot	No
Second handle	Removable <b>EasyGrip</b> handle
Electronic Booster System (EBS)	No
Dimensions	30 7/8" x 5"
Weight	18 lbs
<b>Accessories</b>	Wall support - <b>Included</b>

Choose your model:



MP 350 TP - Coming soon	Ref.	\$
120V/60/1	MP350TP	<b>1 005</b>

**NEW**



Wall support

## MP 800 TP

Wattage	1.6 HP / 1000 W
Voltage	Single Phase - 120 V
Speed	12000 rpm
Blade, bell and shaft	14" length
Detachable blade	✓
Reinforced bell.	✓
Detachable bell	✓
Detachable foot	✓
Second handle	Integrated stainless steel handle
Electronic Booster System (EBS)	✓
Dimensions	30 7/8" x 5"
Weight	18 lbs
<b>Accessories</b>	Wall support - <b>Included</b>

MP 800 TP - Coming soon	Ref.	\$
120V/60/1	MP800TP	<b>2 376</b>

## WHICH MACHINE FOR YOUR TILTING PAN?

Tilting pan height 25-30+ cm

Volume (L)	50-100	100+
Motor base	MP 350 TP	MP 800 TP

[BACK TO SUMMARY](#)

## IMMERSION BLENDERS

# COMBI PRODUCT RANGE

The Robot Coupe whisk attachment available for Mini MP Combi, CMP Combi, MP Combi and MP FW mixers is designed to emulsify, mix, shell, beat and knead.

### POWERFUL

**High-strength motor:**  
+15 % for greater efficiency.

### EASY TO OPERATE

Variable speed button easy to use with one hand.

### ERGONOMIC

Ergonomic handle for easier grasping.

### CONVENIENT

Self regulating speed system for sophisticated preparations.



Salad dressing, mayonnaise, sauces, etc.

## EMULSIFY



## MIX



Pancake batter, tomato pulp, seasoning, etc.

## SEPARATING



Semolina, rice, wheat, quinoa, etc.

## BEAT



Egg whites, chocolate mousse, whipped cream, etc.

## KNEAD/MASH



Mashed potatoes, doughnut dough, batter, etc.

## INNOVATION



## METAL WHISK BOX

### HEAVY DUTY

**Metal** gears inside 2 metal housings to stand up to heavy duty use.

### CLEANING

**Overmolded whisks** to ensure perfect sanitation.

### ERGONOMIC

**Fast coupling** of whisks to the gearbox and the gearbox to the motor housing for easy assembly and disassembly.

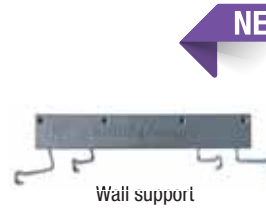

## MMP 190 V.V. Combi

## MMP 240 V.V. Combi

## CMP 250 Combi

Power	270 W
Voltage	Single Phase - 120 V
Speed	2000 to 12500 rpm (mixer attachment) 350 to 1560 rpm (whisk attachment)
Blade, bell and shaft	8" length
Wisk	7" length
Detachable stainless steel blade	✓
Detachable bell	✓
Detachable tube	✓
Metal wisk box	✓
Detachable whisk	✓
EasyPlug	No
Dimensions	20 1/5" x 3"
Weight	7 lbs
<b>Accessories</b>	Aeromix stainless steel - <b>Included</b> Wall support - <b>Included</b>

Power	290 W
Voltage	Single Phase - 120 V
Speed	2000 to 12500 rpm (mixer attachment) 350 to 1560 rpm (whisk attachment)
Blade, bell and shaft	10" length
Wisk	7" length
Detachable stainless steel blade	✓
Detachable bell	✓
Detachable tube	✓
Metal wisk box	✓
Detachable whisk	✓
EasyPlug	No
Dimensions	20 1/5" x 3"
Weight	7 lbs
<b>Accessories</b>	Aeromix stainless steel - <b>Included</b> Wall support - <b>Included</b>

Power	310 W
Voltage	Single Phase - 120 V
Speed	2300 to 10000 rpm (mixer attachment) from 500 to 1800 rpm (whisk attachment)
Blade, bell and shaft	10" length
Wisk	9" length
Detachable stainless steel blade	✓
Detachable bell	✓
Detachable tube	✓
Metal wisk box	✓
Detachable whisk	✓
EasyPlug	✓
Dimensions	29 15/16" - 3 9/16"
Weight	13 lbs
<b>Accessories</b>	Wall support - <b>Included</b>

Choose your model:



MMP 190 V.V. Combi	Ref.	\$
120V/60/1	MMP-190COMBI	766

MMP 240 V.V. Combi	Ref.	\$
120V/60/1	MMP-240COMBI	856

CMP 250 Combi	Ref.	\$
120V/60/1	CMP-250COMBI	1 344

Choose your options:

Options	MMP 190 V.V. Combi		MMP 240 V.V. Combi		CMP 250 Combi	
	Ref.	\$	Ref.	\$	Ref.	\$
Whisk Attachment	27334	299	27334	299	-	-
Whisk Assembly	-	-	-	-	89649	211
Wall rack	-	-	-	-	89630	59

# IMMERSION BLENDERS



## MP 350 Combi

## MP 450 Combi

Power	1 HP / 660 watts
Voltage	Single Phase - 120 V
Speed	3000 to 10000 rpm (Mixer assembly) 500 to 1500 rpm (Whisk assembly)

Power	1.1 HP / 720 watts
Voltage	Single Phase - 120 V
Speed	3000 to 10000 rpm (Mixer assembly) 500 to 1500 rpm (Whisk assembly)

Blade, bell and shaft	14" length
Wisk	10" length

Blade, bell and shaft	18" length
Wisk	10" length

- Detachable stainless steel blade ✓
- Detachable bell ✓
- Detachable tube ✓
- Detachable whisk ✓
- Metal wisk box ✓
- Electronic Booster System (EBS) ✓

- ✓
- ✓
- ✓
- ✓
- ✓
- ✓

Dimensions	30 7/8" - 5" (Mixer assembly) 31 3/4" - 4 3/4" (Whisk assembly)
------------	--

Dimensions	34 3/4" - 5" (Mixer assembly) 31 3/4" - 4 3/4" (Whisk assembly)
------------	--

Weight	18 lbs
--------	--------

Weight	19 lbs
--------	--------

**Accessories** Wall support - **Included**

**Accessories** Wall support - **Included**

Choose your model:



Choose your options:

MP 350 Combi	Ref.	\$
120V/60/1	MP350COMBI	<b>1 639</b>

MP 450 Combi	Ref.	\$
120V/60/1	MP450COMBI	<b>1 857</b>

Options	MP 350 Combi		MP 450 Combi	
	Ref.	\$	Ref.	\$
Whisk Asembly	89553	<b>258</b>	89553	<b>258</b>
Wall rack	89630	<b>59</b>	89630	<b>59</b>
Mixing Tool	27355	<b>1 269</b>	27355	<b>1 269</b>
EasyGrip removable handle	27359	<b>198</b>	27359	<b>198</b>



Wall support



Wall support



## MP 450 FW

Power	1.1 HP / 720 watts
Voltage	Single Phase - 120 V
Speed	250 to 1500 rpm
Whisk	10" length
Metal whisk box	✓
EasyPlug	✓
Electronic Booster System (EBS)	✓
Dimensions	31 3/4" - 5"
Weight	15 lbs

**Accessories** Wall support - **Included**

Choose your model:



Choose your options:

MP 450 FW	Ref.	\$
120V/60/1	MP450FW	1 431

## MP 450 XL FW

Power	1.1 HP / 720 watts
Voltage	Single Phase - 120 V
Speed	150 to 510 rpm
Whisk	27" length
Metal whisk box	✓
EasyPlug	✓
Electronic Booster System (EBS)	✓
Dimensions	47 1/2", diameter 6 15/16"
Weight	20 lbs

**Accessories** Wall support - **Included**

MP 450 XL FW	Ref.	\$
120V/60/1	MP450XLFW	1 912

	MP 450 FW		MP 450 XL FW	
Options	Ref.	\$	Ref.	\$
Whisk Assembly/Mixing Tool	89553	258	27355	1 269

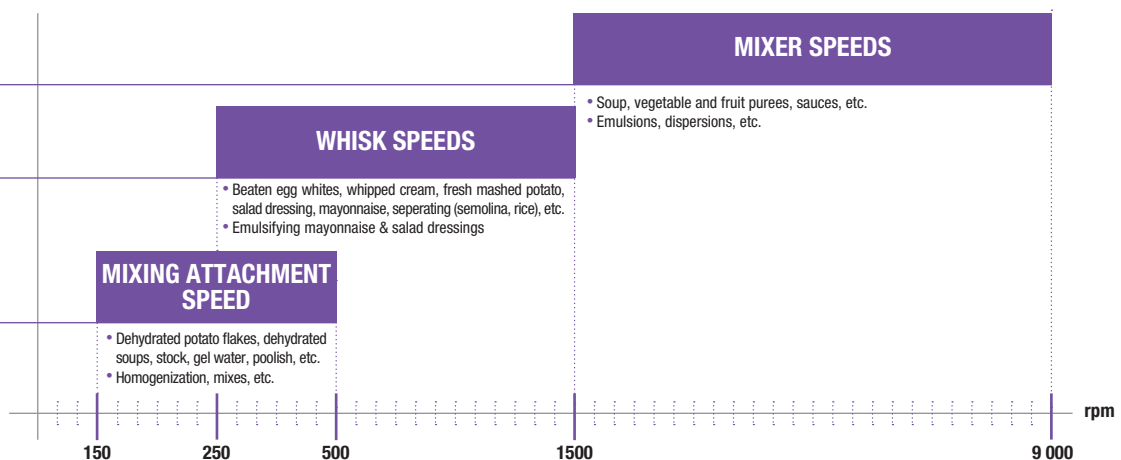

[BACK TO SUMMARY](#)

# IMMERSION BLENDERS

## Dimensions (mm)

Reference	Power	1 Phase	3 Phase 	NEMA #	MACHINE		BOX 1 - BOX 2			Cube	Shipping Weight (Lbs) BOX 1 - BOX 2
					L	W	W	D	H		
MMP190VV - 120V/60/1	270 W	•		5-15P	20 1/5"	3"	18"	7.5"	4.25"	0.33	5
MMP190COMBI - 120V/60/1	270 W	•		5-15P	20 1/5"	3"	18.25"	11.5"	4.25"	0.52	7
MMP240VV - 120V/60/1	290 W	•		5-15P	22 1/3"	3"	18"	7.5"	4.25"	0.33	5
MMP240COMBI - 120V/60/1	290 W	•		5-15P	20 1/5"	3"	18.25"	11.5"	4.25"	0.52	7
CMP250VV - 120V/60/1	310 W	•		5-15P	26"	39/16"	27.25"	9"	4.5"	0.64	10
CMP250COMBI - 120V/60/1	310 W	•		5-15P	29 15/16"	39/16"	22"	13.5"	5"	0.86	13
CMP400VV - 120V/60/1	420 W	•		5-15P	30"	39/16"	36.75"	11"	6"	1.40	11
MP350 - 120V/60/1	660 W	•		5-15P	30 7/8"	5"	36.75"	10.75"	6.25"	1.43	15
MP350VV - 120V/60/1	660 W	•		5-15P	30 7/8"	5"	36.75"	10.75"	6.25"	1.43	15
MP350COMBI - 120V/60/1	660 W	•		5-15P	30 7/8"	5"	27.5"	15.5"	6"	1.48	18
MP450 - 120V/60/1	720 W	•		5-15P	34 3/4"	5"	36.75"	10.75"	6.25"	1.43	15
MP450VV - 120V/60/1	720 W	•		5-15P	34 3/4"	5"	36.75"	10.75"	6.25"	1.43	15
MP450COMBI - 120V/60/1	720 W	•		5-15P	34 3/4"	5"	27.5"	15.5"	6"	1.48	19
MP550 - 120V/60/1	840 W	•		5-15P	36 7/16"	5"	36.75"	10.75"	6.25"	1.43	16
MP600 - 120V/60/1	920 W	•		5-15P	38"	5"	36.75"	10.75"	6.25"	1.43	17
MP800 - 120V/60/1	1000 W	•		5-15P	44.5"	5"	27.25"	15.25"	9.25"	2.22	21
MP 350 TP - 120V/60/1	660 W	•		5-15P	30 7/8"	5"	36.75"	10.75"	6.25"	1.43	18
MP 800 TP - 120V/60/1	1000 W	•		5-15P	30 7/8"	5"	36.75"	10.75"	6.25"	1.43	18
MP450FW - 120V/60/1	720 W	•		5-15P	31 3/4"	5"	27.5"	15.5"	6"	1.48	15
MP450XLFW - 120V/60/1	720 W	•		5-15P	47 1/2"	6 15/16"	28" - 32"	6" - 9"	6" - 7"	1.46 - 1.19	19 - 8