

MP 350 Combi

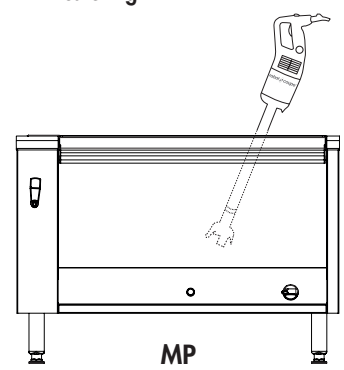

**D** Pan capacity up to 50 L

**▶** Specially designed for intensive use in commercial/institutional catering



**A SALES DESCRIPTION**

Ideal for blending soups and pureeing fruit and vegetables. Special institutional catering model intended for intensive use. In its Combi version, the whisk function can be used for mashed potato and pancake batter.

**B TECHNICAL DESCRIPTION**

MP 350 Combi Immersion Blenders. 120V/60/1. Power: 1 HP/660W. Variable speed: 3,000-10,000 rpm (blender function) and 500-1,500 rpm (whisk function). 100% stainless-steel blades, bell and shaft (total length: 14"). "EasyPlug" system with detachable power cord.

**C TECHNICAL CHARACTERISTICS**

Effective output	1 HP/660W
Electrical data	120V/60/1 5.5 amps – plug supplied
Variable speed	3,000 to 10,000 rpm (blender function) 500 to 1,500 rpm (whisk function)
Recyclability	95%
Net weight	13 lb
Reference	MP350COMBI

**E CHARACTERISTICS AND BENEFITS**

**MOTOR UNIT**

- Power 1 HP/660W
- Stainless-steel motor unit with air vents in the top section to ensure watertightness
- Variable speed 3,000 -10,000 rpm (blender function) and 500-1,500 rpm (whisk function).
- Self-regulating speed system
- New patented "EasyPlug" system making it easier to replace the power cord during after-sales servicing.
- Cord winding system for tidy storage and optimum lifespan
- The indicator lights up when machine starts functioning and the cable is not damaged and correctly plugged in on both sides (wall socket and EasyPlug).

**SHAFT AND BELL**

- 100% stainless-steel blades, bell and shaft (total length: 14").
- Foot with detachable bell and blades (patented system exclusive to Robot Coupe) for optimum sanitation.
- Watertight bell design for optimum lifespan.
- Sturdy all-metal housing for whisk attachment to handle very thick mixtures.

**STANDARD ATTACHMENTS**

- Wall-mounted Immersion Blenders holder.
- Tool for attaching and detaching the blades.

**STANDARDS**

ETL electrical and sanitation Listed/ cETL (Canada)



MP 350 Combi

MP 350 Combi

MP 350 Combi

G

DRAWINGS & DIMENSIONS

120V/60/1 – power cord and plug supplied

