



BEVERAGE-AIR

Project: _____	AIA#
Item: _____	
Location: _____	SIS#
Approved: _____	

WTR60AHC WORKTOP REFRIGERATOR

WORKTOP REFRIGERATOR

WTR60AHC Solid Door With Flat Top Hydrocarbon Series

MODEL:
WTR60AHC-FLT



7 Year Parts/Labor Warranty
7 Year Compressor Warranty

CABINET CONSTRUCTION

- Stainless steel front, sides, doors and grille (galvanized back & bottom)
- Interior liner is made of corrosion resistant aluminum
- Stainless steel top for added durability
- Flat top
- Full electronic control
- Interior thermometer is standard
- Self-closing doors with 120° stay-open feature, on cartridge style hinges
- Magnetic gasket attached to each door for positive seal
- 6" Casters, two (2) with brakes standard
- Four (4) epoxy-coated steel wire shelves
- Field-reversible doors (hinge kit not included)

OPTIONS & ACCESSORIES

- Stainless steel back
- Stainless steel interior
- 16 Gauge stainless steel top
- Additional shelves
- Shelf clips
- Glass door option
- Right or left hinged door
- Locks (solid doors only)
- Wire shelf divider
- Cutting board
- 3" Casters
- 6" Legs (stainless steel, black or seismic/flange)
- Low profile casters
- Roller kit
- Remote option* (see note on back on page)

REFRIGERATION SYSTEM

- Uses environmentally friendly, energy efficient R290 refrigerant, and meets all regulatory requirements for CARB, SNAP, DOE & more
- Adaptive defrost
- Epoxy coated evaporator coil
- Refrigerators capable of maintaining product temperature between 36°F and 38°F



Please verify qualifying units by visiting:
www.energystar.gov/cfs

3779 Champion Blvd., Winston-Salem, NC 27105
1-888-845-9800 Fax: 1-336-245-6453
Beverage-Air.com Sales@bevair.com



BEVERAGE-AIR

MODEL	WTR60AHC-FLT
EXTERNAL DIMENSIONAL DATA	
Width Overall	60"
Depth Overall with Handle & Bumper	32"
Height Overall with 6" Casters	35 5/8"
Number of Doors	2
Depth with Door Open 90°	55 1/4"
Door Openings	22 5/8" x 21 5/8"
INTERNAL DIMENSIONAL DATA	
NET Capacity (cubic ft.)	14.75
Internal Width Overall (in)	56"
Internal Depth Overall (in)	15 3/8"
Internal Height Overall (in)	23"
Number of Shelves	4
ELECTRICAL DATA	
Full Load Amperes	3.0
REFRIGERATION DATA	
Horsepower	1/5
Capacity (BTU/Hr)	1350
Heat Rejection (BTU/Hr)	2025
Charge (lbs/grams/ounces)	0.2425 / 110 / 3.9
SHIPPING DATA	
Gross Weight - Crated	300 lbs
Height - Crated	35"
Width - Crated	62"
Depth - Crated	33"

*NOTE: Remote units are field wired and come with 6" legs. Refrigerant must be specified at time of order.

We reserve the right to change specifications and product design without notice. Such revisions do not entitle the buyer to corresponding changes, improvements, additions or replacements for previously purchased equipment. Dimensional tolerances +/- 1/4". Metric dimensions (MM).

Worktop Refrigerator Model: WTR60AHC-FLT

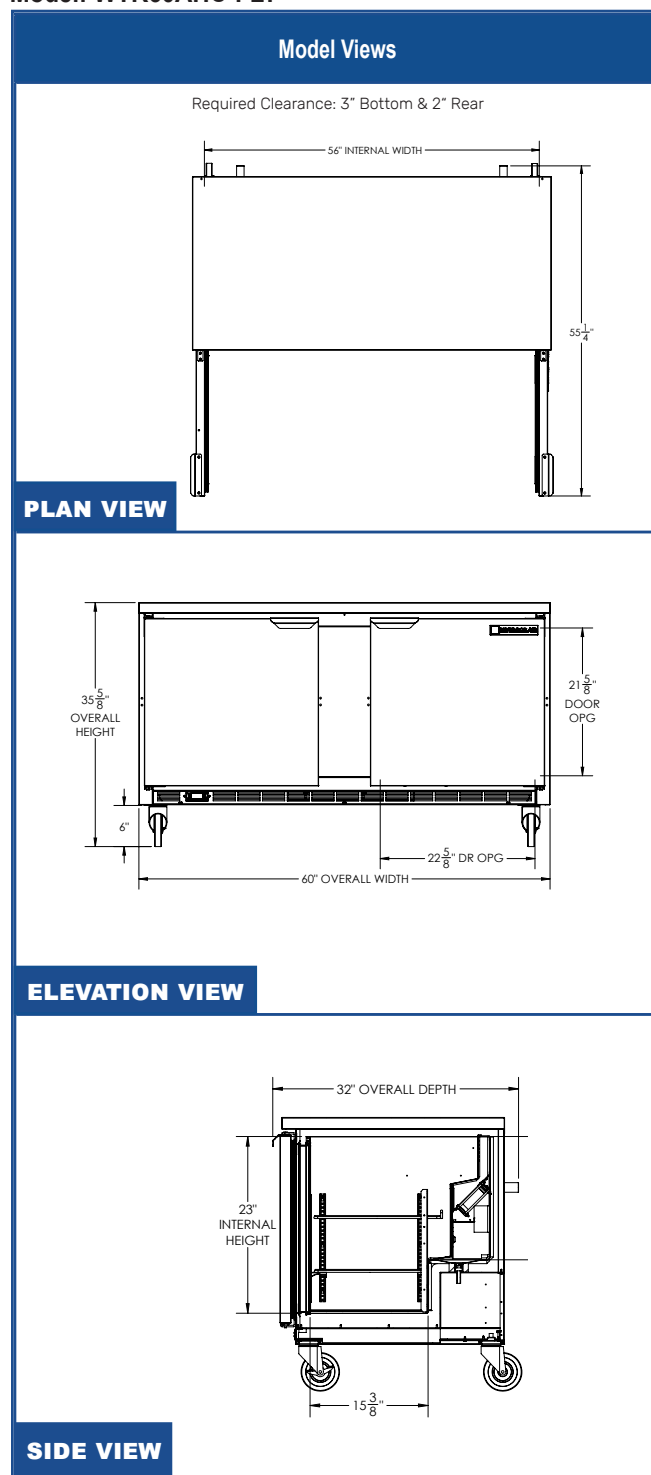

ELECTRICAL CONNECTION



115/60/1
NEMA 5-15P

Unit pre-wired at factory and include 8' long cord and plug set.