



BEVERAGE-AIR

Project: _____	AIA#
Item: _____	
Location: _____	SIS#
Approved: _____	

BB24HC BACK BAR REFRIGERATOR: FOOD RATED

BAR EQUIPMENT- BACK BAR REFRIGERATOR

**MODEL:
BB24HC-1-FG-S**

BB24HC Glass Door Food Rated
Hydrocarbon Series

**3 Year Parts/Labor Warranty
Additional 4 Year Compressor Warranty**



CABINET CONSTRUCTION

- Exterior is stainless steel front with continuous coil coated sides
- Stainless steel interior
- Full electronic control
- Stainless steel top
- 1 ½" Stainless steel top
- Self-closing door with 120° stay-open feature
- Field reversible door (hinge kit not included)
- LED lighting
- Certified for open food product
- Four (4") heavy duty casters 2 with locks
- Balanced, forced air refrigeration system provides rapid chilling of product

OPTIONS & ACCESSORIES

- Stainless steel exterior
- Wine model (40°-60° models)
- Underbar model option
- Galvanized sub-top

REFRIGERATION SYSTEM

- Uses environmentally friendly, energy efficient R290 refrigerant, and meets all regulatory requirements for CARB, SNAP, DOE & more
- Adaptive defrost
- Epoxy coated evaporator coil
- Maintains product temperature between 36°F and 38°F



Please verify qualifying units by visiting:
www.energystar.gov/cfs

3779 Champion Blvd., Winston-Salem, NC 27105
1-888-845-9800 Fax: 1-336-245-6453
Beverage-Air.com Sales@bevair.com



BEVERAGE-AIR®

MODEL	BB24HC-1-FG-S
EXTERNAL DIMENSIONAL DATA	
Width Overall	24"
Depth Overall	30 1/8"
Height Overall	37 3/4"
Number of Doors	1
Depth with Door Open 90°	50 3/4"
Door Opening (in)	19 3/4" x 28"
INTERNAL DIMENSIONAL DATA	
NET Capacity (cubic ft.)	7.66
Internal Width Overall (in)	20"
Internal Depth Overall (in)	22 1/4"
Internal Height Overall (in)	29 1/2"
Number of Shelves	2
Number of 1/2 Kegs	1
ELECTRICAL DATA	
Full Load Amperes	2.0
REFRIGERATION DATA	
Horsepower	1/6
Capacity (BTU/Hr)	1094
Heat Rejection (BTU/Hr)	1641
Charge (lbs/grams)	0.1213/55
SHIPPING DATA	
Gross Weight - Crated	200 lbs
Height - Crated	46"
Width - Crated	27"
Depth - Crated	32"

*NOTE: Remote units are field wired and come with 6" legs.
Refrigerant must be specified at time of order.

Bar Equipment-Back Bar Refrigerator Model: BB24HC-1-FG-S

Model Views

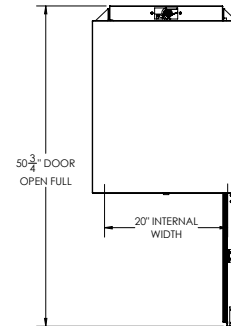

PLAN VIEW

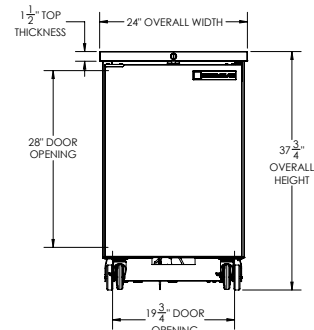

ELEVATION VIEW

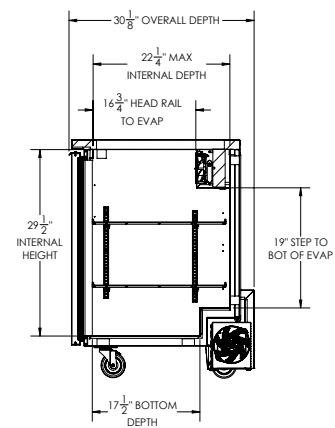

SIDE VIEW

ELECTRICAL CONNECTION



115/60/1
NEMA 5-15P

Unit pre-wired at factory and include 8' long cord and plug set.



3779 Champion Blvd., Winston-Salem, NC 27105 1-888-845-9800 Fax: 1-336-245-6453 Beverage-Air.com Sales@bevoir.com

an Ali Group Company



The Spirit of Excellence