

# MIXER KETTLE, DIRECT STEAM TABLE TYPE, TILTING 2/3 JACKETED

Project \_\_\_\_\_  
 Item \_\_\_\_\_  
 Quantity \_\_\_\_\_  
 FCSI Section 11400 \_\_\_\_\_  
 Approved \_\_\_\_\_  
 Date \_\_\_\_\_

## Models

- MKDT-12-T



## Standard Features

- Infinitely Variable Speed for all conditions; Scraper from 0-70 rpm, Agitator from 0-210 rpm
- Removable (without tools) Nylon Blade scrapes entire Jacketed surface
- 3/4 Horsepower D.C. Timing Belt Drive
- Safety device prevents high speed starts
- Mixing stops when bridge is lifted - includes safety cover and screen
- Agitator and Scraper are Bayonet mounted for easy removal
- Enclosed, Balanced, 10 Gauge Stainless Steel Mixer Bridge
- Kettle and all Exterior Surfaces are Stainless Steel
- Steam Control Valve built into Trunnion
- Factory Installed Steam Control Kit
- 50 psi Steam Jacket Rating
- Tilt Handle interchangeable for left or right operation
- Large Pouring Lip
- Gallon Markings on Scraper Shaft
- Standard 120 volts, 60 Hz, Single phase, 3 wire
- Typical approvals include NSF and ASME
- 316 Stainless Steel Interior
- Two piece cover with safety screen

## Short Form Specifications

Shall be CLEVELAND, Model MKDT-12-T, Table Type, Tilting, 12 Gallon, Direct Steam Mixer Kettle, 50 psi Jacket Rating, Factory installed Steam Control Kit, Type 316 Stainless Steel Interior, Steam Control Valve built into Trunnion. Infinitely Variable Speed, 3/4 H.P. Timing Belt Drive. Bayonet Mounted Agitator and Scraper with Removable Blades, Safety Device prevents high speed starts. Mixing stops when Bridge is lifted. Kettle and all Exterior Surfaces are Stainless Steel. 316 Stainless Steel Interior.

## Options & Accessories

- Double or Single Pantry Faucet (DPK or SPK)
- Faucet Bracket (FBKT)
- Product Time/Temperature Controls and Indicators
- Kettle Accessory Kit (KAK) includes:
  - Clean-up Brush (CB)
  - 36" Kettle Paddle (KP)
  - 36" Kettle Whip (KW)
  - 36" Kettle Brush (KB)
  - Draw-off Brush (DB)
  - 24 oz. Ladle (KL)
- Food Strainer (FS-12)
- Flow Diverter (FD)
- Pressure Reducing Valve (PRV-K)
- Water Meter (GMF or LMF) Wall Mount or on Stand (SWM)
- Water Cooling (AWC-1)

KE004046-78

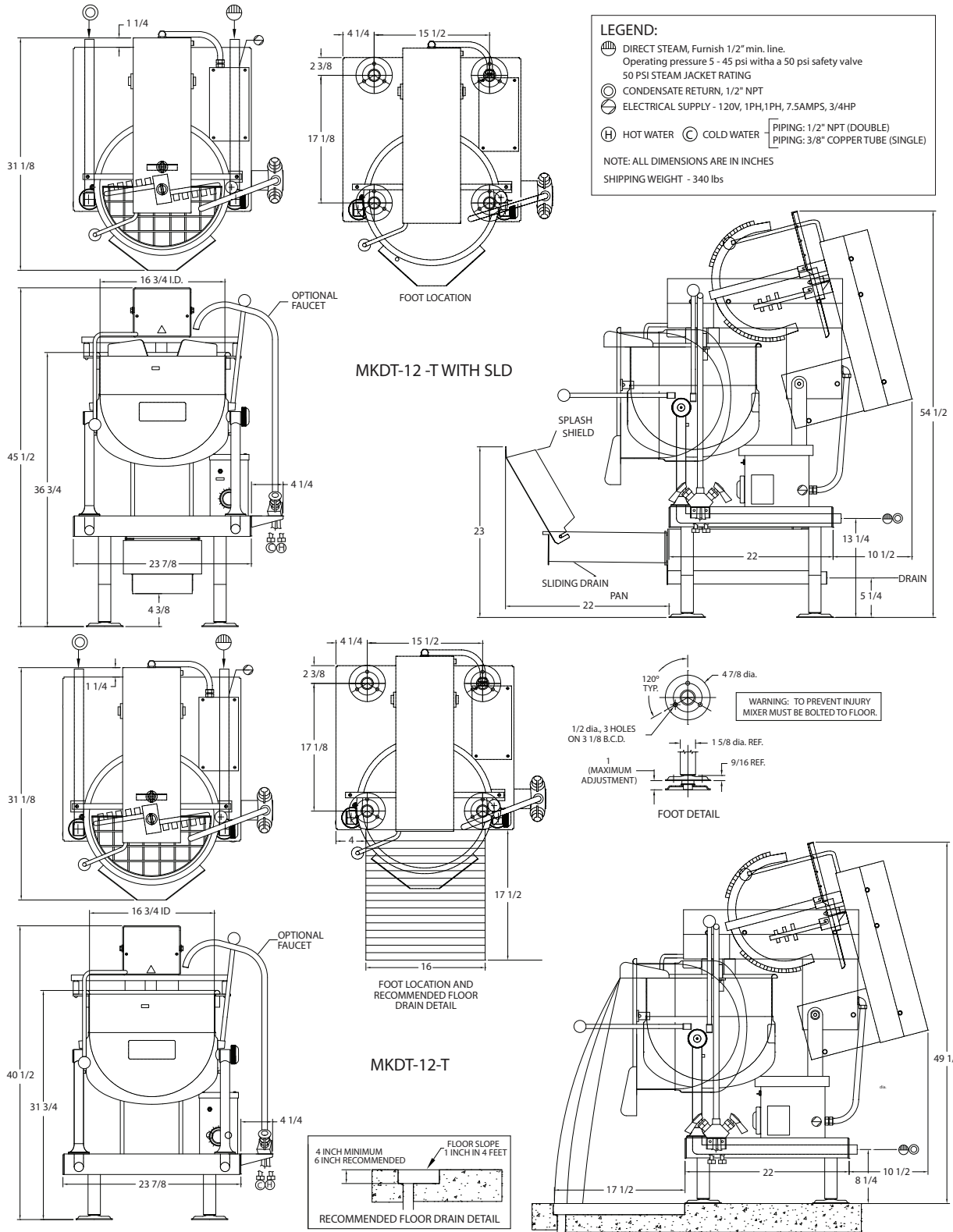

**NOTES:**

Cleveland Range reserves right of design improvement or modification, as warranted.  
 Many regional, state and local codes exist and it is the responsibility of the owner and installer to comply with the codes.  
 Installation of backflow preventers, vacuum breakers and other specific code requirements is the responsibility of the owner and installer.  
 Cleveland Range equipment is built to comply with applicable standards for manufacturers. Included among those approval agencies are U.L., A.G.A., NSF, ASME/N.Bd., CSA, CGA, ETL and others.

(NOT TO SCALE)