

Project _____
 Item _____
 Quantity _____
 FCSI Section 11400 _____
 Approved _____
 Date _____

LEG TYPE, GAS-FIRED KETTLES

STATIONARY, 2/3 STEAM JACKETED "SPASH PROOF SERIES"
 40, 60, 80 or 100 GALLONS (150, 225, 300 or 337 LITERS)

Models

- KGL-40 • KGL-80
- KGL-60 • KGL-100



Standard Features

- High efficiency Power Burner Heating System (62% to 65% efficiency)
- Fast Heat-up and Recovery Time, 140M BTU's on 40 gallon models, 190M BTU's on 60 gallon and larger
- Insulated Heat Exchanger
- Automatic Ignition System
- Steam jacket permanently filled with treated, distilled water. Venting and/or refilling not required
- Solid State Controls, for Temperature and Low Water Safety, in a plug-in Control Module
- Control Panel includes:
 - Precise, consistent temperature control: less than $\pm 1^{\circ}\text{C}$ variance (ideal for simmering).
 - L.E.D. Indicators for Heat Cycle and Low Water
 - Warning.
 - Power "on/off" Switch
- Front mounted combination Pressure/Vacuum Gauge
- Type 316 Stainless Steel with #4 finish on kettle
- 2" diameter Tangent Draw-Off Valve with Drain Strainer
- Support Legs with level adjustable feet, flanged for floor bolting
- Spring-assisted, hinged, rotatable, domed Stainless Steel Cover
- 50 PSI Steam Jacket Rating and Safety valve
- Standard voltage is 115 volts, 60 Hz, single-phase, supplied with cord and plug
- Standard for natural gas operation
- Faucet Mounting Bracket (FBK)
- Typical approvals include AGA, CSA, CE, NSF and ASME

Short Form Specifications

Shall be CLEVELAND, Gas-fired Stationary Kettle, Model KGL-____; ____ gallons. 2/3 Steam Jacketed, Power Burner Heating System, Insulated Heat Exchanger, 50 psi Steam Jacket Rating. Infinite Variable Temperature Control, L.E.D. indicators for Heat Cycle and Low Water Warning, spring-assisted Cover, 2" Tangent Draw-off Valve with Drain Strainer, Automatic Ignition System. 316 Stainless Steel Interior.

Options & Accessories

- Hot and Cold Water Faucet with Swing Spout (DPK)
- Cooking Baskets and Tri-Basket Supports (BS and TBS)
- Drain Strainers (DS-)
- 3" diameter Tangent Draw-off Valve with Drain Strainer (TD3)
- Kettle Accessory Kit (KAK) includes:
 - Clean-up Brush (CB)
 - 36" Kettle Paddle (KP)
 - 36" Kettle Whip (KW)
 - 36" Kettle Brush
 - Draw-Off Brush (DB)
 - 24 oz. Ladle (KL)
- Automatic Water Meter (GMF or LMF)
- Measuring Strip (MS)
- Option for Propane Gas operation
- Correctional Package
- Heat Deflector Shield (HS001)

KE004046-71

CAPACITIES: (in 8 oz. servings, other sizes may be calculated)
 40 Gallon / 150 liters . . . 640 servings
 60 Gallon / 225 liters . . . 960 servings
 80 Gallon / 300 liters . . . 1280 servings
 100 Gallon / 375 liters . . . 1600 servings

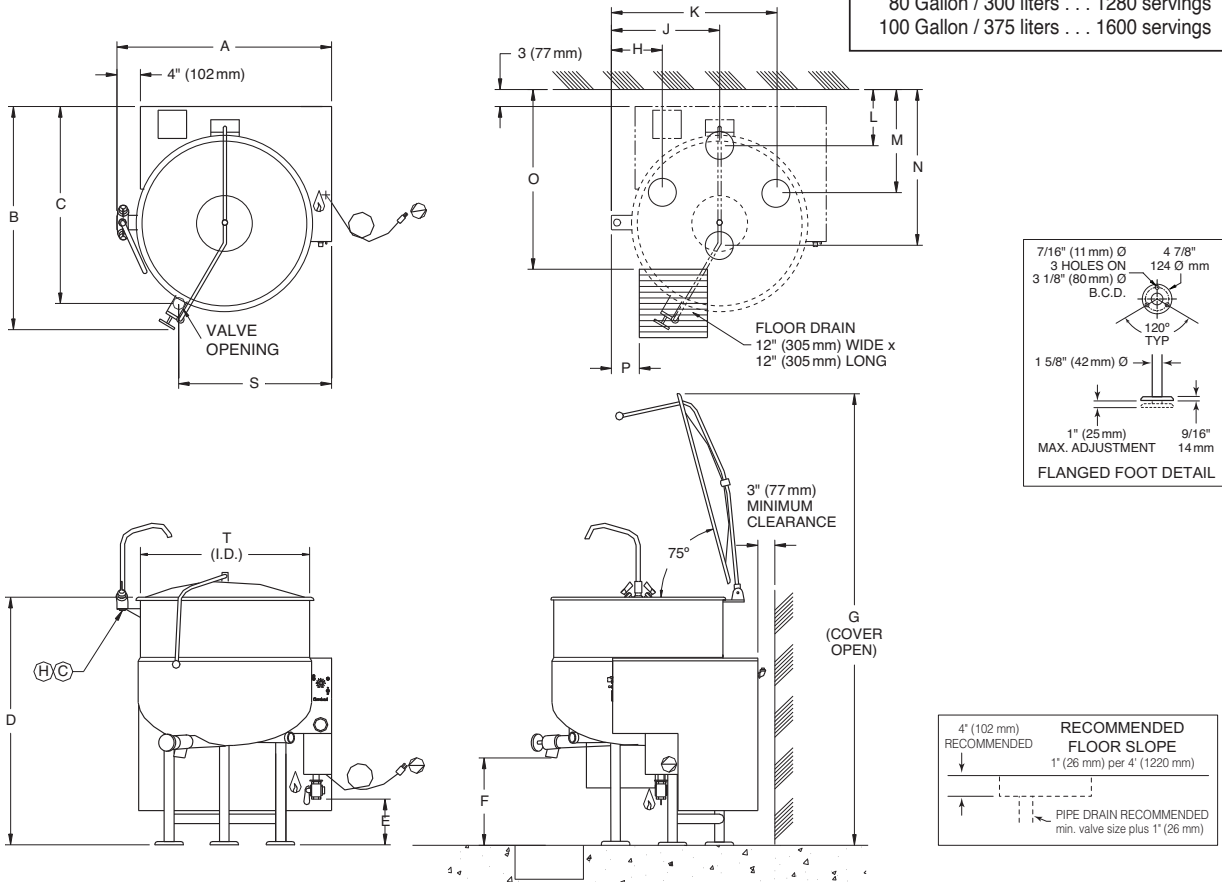

UNIT SHOWN WITH OPTIONAL 2" TANGENT DRAW-OFF VALVE, SPRING ASSIST COVER AND HOT & COLD WATER FAUCET.

DIMENSIONS

GALS./LITERS		A	B	C	D	E	F	G	H	J	K	L	M	N	O	P	S	T.I.D.
40	IN	35 1/8	37	32 1/4	40 1/2	9 1/4	16	71 1/2	9 9/16	17 3/4	25 15/16	10 3/8	18 5/8	26 7/8	28 1/2	4 5/8	24 1/2	26
150	mm	893	940	820	1029	235	407	1817	243	451	659	264	474	683	724	118	648	661
60	IN	38 1/4	39	34 1/4	43 1/2	8 3/4	14 1/4	75	8 15/16	19 1/8	29 5/16	10 3/8	18 5/8	27 7/8	30 1/4	5 1/4	27	29 1/2
225	mm	972	991	870	1105	223	362	1905	228	486	745	264	474	709	769	134	686	750
80	IN	41 5/8	42 3/8	35 1/2	45 1/2	8 3/4	15 1/2	79	9 1/4	20 3/4	32 1/4	10 3/8	18 5/8	29 5/8	31 1/2	6 5/8	29	33
300	mm	1058	1077	902	1156	223	394	2007	235	528	820	264	474	753	801	169	737	839
100	IN	44	43 1/2	36 1/2	47 1/2	8 3/4	15 1/2	83 1/2	9 1/8	21 7/8	34 5/8	10 3/8	18 5/8	31 1/4	32 1/2	7 1/2	30 1/2	35 1/2
375	mm	1118	1105	928	1207	223	394	2121	232	556	880	264	474	794	826	191	775	902

Shipping Weights & Dimensions

Model - KGL-40	Weight - 454 lbs Width - 44" Depth - 44" Height - 54"
KGL-40	Weight - 510 lbs Width - 44" Depth - 44" Height - 54"
KGL-40	Weight - 597 lbs Width - 56" Depth - 55" Height - 59"

GAS			ELECTRIC	WATER	CLEARANCE
NATURAL	PROPANE	B.T.U. RATING	120V-1 Phase, 60 Hz, 10 amps	1/2" dia. Soft Copper Tubing (each)	RIGHT = 3" LEFT = 3" REAR = 3" Allow 6" space minimum from rear and sides when located near combustible walls. 12" recommended on right side for service
Piping: 3/8" N.P.T.	Piping: 3/8" N.P.T.	40 gal. 140,000			
Supply pressure: 4.00" W.C. minimum 14.00" W.C. maximum	Supply pressure: 4.00" W.C. minimum 14.00" W.C. maximum	60 gal. 190,000 80 gal. 190,000 100 gal.			
Manufacturer must be notified if unit will be operated above 2,000 ft. altitude.					

NOTES:
 Cleveland Range reserves right of design improvement or modification, as warranted.
 Many regional, state and local codes exist and it is the responsibility of the owner and installer to comply with the codes.
 Cleveland Range equipment is built to comply with applicable standards for manufacturers. Included among those approval agencies are U.L./NSF#4 and CSA (AGA, CGA).

(NOT TO SCALE)

Gas Kettles