

Project _____
 Item _____
 Quantity _____
 FCSI Section 11400 _____
 Approved _____
 Date _____

QUAD-LEG, DIRECT STEAM TILTING, 2/3 STEAM JACKETED 80 OR 100 GALLONS (300 OR 375 LITERS)

Models

- KDL-80-T • KDL-100-T • KDL-125-T • KDL-150-T



Shown with optional Spring-Assisted Cover, 2" Tangent Draw-Off Valve

- Condensate Drain Valve with insulated handle
- Steam Control Valve mounted on console
- Typical approvals include NSF and ASME
- 316 Stainless Steel Interior

Options & Accessories

- Lift-off Covers (CL)
- Steam Control Kit includes: Steam Trap, Condensate Strainer, Check Valve, nipples and fittings, factory assembled and mounted on kettle (SCK2)
- Spring-assisted, hinged, rotatable, domed Stainless Steel Cover (CHS-)
- Hot and Cold Water Faucet, comes with Swing Spout (DPK)
- 2" or 3" diameter Tangent Draw-Off Valve (TD2 or TD3*), *TD3 will raise height of kettle by 5-5/8" (143mm)
- 3" diameter Butterfly Valve (BV3)
- 100 psi Pressure Option (PO) (for 125 gallons and larger)
- Cooking Baskets and Tri-Basket Supports (BS and TBS)
- Pan Carrier (PCK)
- Measuring Strips (MS)
- Gallon Markings (KM)
- Kettle Accessory Kit (KAK) includes:
 - Clean-up Brush (CB)
 - 36" Kettle Paddle (KP)
 - 36" Kettle Whip (KW)
 - 36" Kettle Brush (KB)
 - Draw-off Brush (DB)
 - 24 oz. Ladle (KL)
- Swing Funnels for drain (SF)
- Faucet Mounting Bracket (FBKT)
- Pressure Reducing Valve for regulating incoming steam pressure of over 45 psi (PRV-K)
- Hot and cold, or cold only, Kettle Filler with 60" Hose (DKF-K or SKF-K)
- Automatic Water Cooling (AWC-1), requires Console Mounting Option
- Alternate Mounting Systems - Console Mounting
- Automatic Water Meter (GMF or LMF)
- Water Meter Stand (SWM)
- Food Strainer (FS)
- Flow Diverter (FD)
- Drain Strainers (DS-)
- Pre-Rinse Spray Head and Hose (PRSK)
- Heat Deflector Shield (HS001)
- Correctional Packages

Short Form Specifications

Shall be CLEVELAND, Direct Steam Kettle, Quad-leg mounted, Model KDL - _____ - T, _____ gallons, Tilting (hand or power) 2/3 Steam Jacketed. 50 psi Steam Jacket Rating on 80 - 100 gallon, 35 psi on 125 gallon and larger; Steam Control Valve; heavy re-enforced Rolled Rim. To operate, connect directly to a steam source supplying 10 to 45 psi steam. 316 Stainless Steel Interior.

Standard Features

- Kettle legs of 158" OD, type 304 Stainless Steel, with 3 level adjustable feet, with three-bolt flanges for floor bolting
- Type 304 Stainless Steel construction, with #4 finish on kettle and supports
- Tilting Mechanism with permanently lubricated, self-locking, Worm Drive of space saving design
- 50 psi Steam Jacket Rating on 80 - 100 gal. models, 35 psi Steam Jacket Rating on 125 - 150 gal. models
- 50 psi chrome plated Safety Valve on 80 - 100 gal. models, 35 psi chrome plated Safety Valve on 125 - 150 gal. models
- High Capacity Pouring Lip

KE004046-54

CAPACITIES: (in 8 oz. servings, other sizes may be calculated.)
 80 Gallon / 300 liters . . . 1280 servings
 100 Gallon / 375 liters . . . 1600 servings
 125 Gallon / 475 liters . . . 2000 servings
 150 Gallon / 575 liters . . . 2400 servings

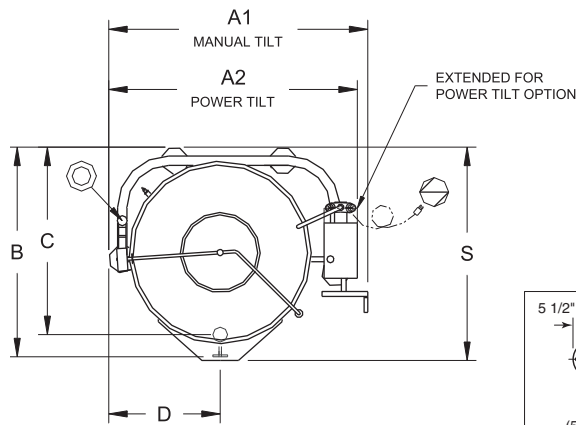

NOTE: TD3, 3" tangent draw off will raise height of kettle by 5-5/8" (143mm).

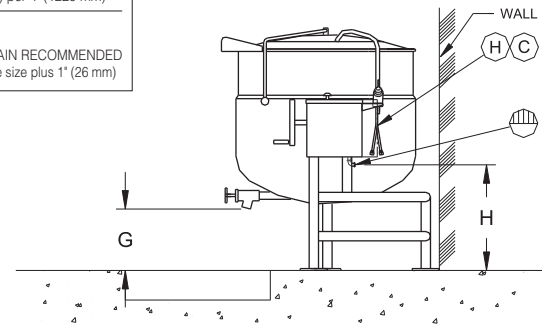
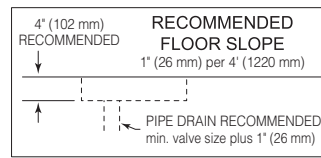
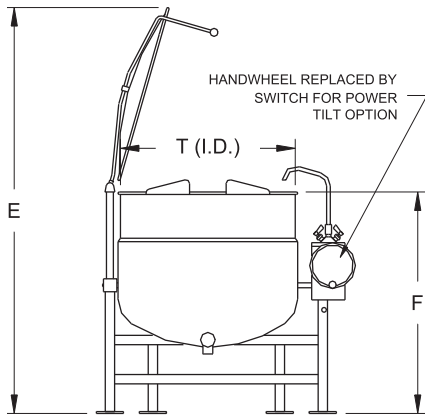
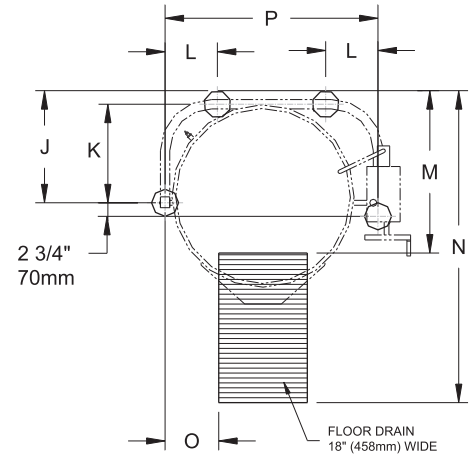
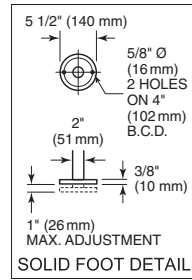

UNIT SHOWN WITH OPTIONAL 2" TANGENT DRAW-OFF VALVE, SPRING ASSIST COVER, HOT AND COLD WATER FAUCET AND STEAM CONTROL KIT.

DIMENSIONS

GALS./ LITERS		A1	A2	B	C	D	E	F	G	H	J	K	L	M	N	O	P	S	T.I.D.
80	IN	48 5/8	47	38 3/8	35 5/8	21 5/8	79 1/8	42 5/8	12 1/2	21 1/4	20 1/2	17 1/2	11 3/8	29 5/8	60	10 1/8	40 3/4	39	33
300	IN	1236	1194	975	905	550	2010	1083	318	540	521	445	289	753	1524	258	1036	991	839
100	IN	51 1/8	49 1/2	43	38 3/8	22 7/8	86 1/8	44 7/8	12 3/4	22 1/4	23	20	11 5/8	32 5/8	64 1/4	11 1/8	43 1/4	43 1/2	35 1/2
375	mm	1299	1258	1093	975	582	2188	1140	324	566	585	508	296	829	1632	283	1099	1105	902
125	IN	55 5/8	54	48	43 1/4	25 1/8	90	46 3/8	13 3/4	24 1/2	27	24	11 7/8	38 1/4	72	13 3/8	47 3/4	50	40
475	mm	1413	1372	1220	1099	639	2286	1178	350	623	686	610	302	972	1829	340	1213	1270	1016
150	IN	55 5/8	54	48	43 1/4	25 1/8	94	50 3/4	13 1/2	25 1/4	27	24	11 7/8	38 1/4	72	13 3/8	47 3/4	50	40
575	mm	1413	1372	1220	1099	639	2388	1290	342	642	686	610	302	972	1829	340	1213	1270	1016

DIRECT STEAM	ELECTRIC	WATER	CLEARANCE						
Steam Supply: • Furnish 3/4" IPS minimum line. • Operating Pressure 10 to 45 psi.	<table border="1"> <thead> <tr> <th>VOLTS 1 PH</th> <th>AMPS</th> </tr> </thead> <tbody> <tr> <td>115</td> <td>5</td> </tr> <tr> <td>240</td> <td>2.5</td> </tr> </tbody> </table> For Power Pour models	VOLTS 1 PH	AMPS	115	5	240	2.5	1/2" O.D. copper tube. When ordered with optional faucet.	RIGHT = 4.00" handle clearance LEFT = 0" REAR = 0"
VOLTS 1 PH	AMPS								
115	5								
240	2.5								

NOTES:

Cleveland Range reserves right of design improvement or modification, as warranted.
 Many regional, state and local codes exist and it is the responsibility of the owner and installer to comply with the codes.
 Installation of backflow preventers, vacuum breakers and other specific code requirements is the responsibility of the owner and installer.
 Cleveland Range equipment is built to comply with applicable standards for manufacturers. Included among those approval agencies are U.L., A.G.A., NSF, ASME/N.Bd., CSA, CGA, ETL and others.

(NOT TO SCALE)

Direct Steam Kettles