



Warewashing Systems

INSTALLATION, OPERATION, AND SERVICE MANUAL



TEMPSTAR® SERIES DOOR-TYPE DISHMACHINES

TempStar HH-E Manual • 07610-002-23-32-AG

TEMPSTAR® HH-E

**MANUFACTURER'S LIMITED WARRANTY
(APPLICABLE ONLY IN THE UNITED STATES AND CANADA)**

WARRANTY REGISTRATION:

To register your Jackson Dishmachine's warranty go to jacksonwws.com/warranty or call 1-888-800-5672. Failure to register the Dishmachine will void the warranty.

ONE YEAR LIMITED PARTS AND LABOR WARRANTY

For a period of one (1) year from date of original installation of a new Jackson Dishmachine (but in no event to exceed eighteen (18) months from date of shipment from Jackson's factory), Jackson WWS, Inc. (Jackson) will repair or replace, at its discretion, any original part that proves defective in materials or workmanship at the time the Dishmachine was purchased; provided that (i) the Dishmachine has not been altered, (ii) the Dishmachine has been properly installed, maintained, and operated under normal use conditions and in accordance with the applicable installation, operation and service manual available on the Jackson website, and (iii) a warranty claim is reported to a Jackson Authorized Service Agency within the warranty period. This warranty includes replacement with Jackson specified genuine replacement parts, purchased directly from a Jackson Authorized Parts Distributor or Service Agency. Use of generic replacement parts may create a hazard and shall void this warranty.

THIS WARRANTY DOES NOT APPLY OUTSIDE THE UNITED STATES AND CANADA.

Jackson will pay the labor to repair or replace a defective original part as a part of the warranty, provided that a Jackson Authorized Service Agency performs the labor. Any repair or replacement work by anyone other than a Jackson Authorized Service Agency is the sole responsibility of the purchaser. Labor coverage is limited to regular hourly rates; Jackson will not pay overtime premiums or emergency service charges.

Accessory components (such as table limit switches, pressure regulators, and drain water tempering kits) that are not installed by Jackson at the factory and are shipped with the Dishmachine carry only a (1) one-year parts warranty. Labor to repair or replace these components is not included in the warranty or covered by Jackson. Booster heaters not manufactured by Jackson are not covered by this warranty but are warranted by their respective manufacturers.

This warranty is void if any defect or failure is a direct result from shipping, handling, fire, water, accident, alteration, modification, misuse, abuse, flood, acts of God, burglary, casualty, attempted repair by unauthorized persons, use of replacement parts not authorized by Jackson, improper installation, installation not in accordance with local electrical and plumbing codes, if the serial number has been removed or altered, if the Dishmachine is used for any purpose other than originally intended, or if the equipment is installed for residential use.

Jackson does not authorize any other entity or person, including, without limitation, any entity or person who deals in Jackson Dishmachines, to change this warranty or create any other obligation in connection with Jackson Dishmachines.

TRAVEL LIMITATIONS:

Jackson limits warranty travel time to the customer site within 50 miles of the Jackson authorized service agent's office and during regular business hours. Jackson will not pay for travel time and mileage that exceeds these limits, or any fees such as those for air or boat travel without prior authorization.

REPLACEMENT PARTS WARRANTY:

For a period of (90) ninety days from the date of installation by a Jackson Authorized Service Agency (but in no event to exceed (180) one-hundred-eighty days from the date of purchase from a Jackson Authorized Parts Distributor or Service Agency), Jackson will repair or replace, at its discretion, any Jackson genuine replacement parts that prove defective in materials or workmanship at the time the replacement parts were installed. This warranty does not include paying the labor to repair or replace the replacement part. This warranty is subject to all conditions, exclusions and limitations applicable to the Dishmachine.

**MANUFACTURER'S LIMITED WARRANTY (CONT.)
(APPLICABLE ONLY IN THE UNITED STATES AND CANADA)**

PRODUCT CHANGES:

Jackson reserves the right to make changes in design and specification of any component of the Dishmachine as engineering or necessity requires.

DISCLAIMER OF WARRANTIES:

THERE ARE NO WARRANTIES, EXPRESSED OR IMPLIED, INCLUDING, WITHOUT LIMITATION, ANY IMPLIED WARRANTY OF FITNESS FOR A PARTICULAR PURPOSE OR MERCHANTABILITY, THAT ARE NOT SET FORTH HEREIN, OR THAT EXTEND BEYOND THE DURATION HEREOF.

LIMITATION OF REMEDIES AND LIABILITIES:

YOUR SOLE AND EXCLUSIVE REMEDY UNDER THIS LIMITED WARRANTY SHALL BE PRODUCT REPAIR OR REPLACEMENT AS PROVIDED HEREIN.

UNDER NO CIRCUMSTANCES WILL JACKSON BE LIABLE FOR ANY INCIDENTAL OR CONSEQUENTIAL DAMAGES, OR FOR DAMAGES IN THE NATURE OF PENALTIES. JACKSON'S LIABILITY ON ANY CLAIM OF ANY KIND WITH RESPECT TO THE GOODS OR SERVICES COVERED HEREUNDER SHALL IN NO CASE EXCEED THE PRICE OF THE GOODS OR SERVICES OR PART THEREOF WHICH GIVES RISE TO THE CLAIM.

ITEMS NOT COVERED:

THIS WARRANTY DOES NOT COVER (1) ADJUSTMENTS INCLUDING, BUT NOT LIMITED TO, TIMER CAMS, THERMOSTATS, DOORS, TANK HEATER ADJUSTMENTS OR CLUTCHES; (2) AIR FREIGHT OR OVERNIGHT FREIGHT; (3) ANY AMOUNT EXCEEDING ORIGINAL PURCHASE PRICE; (4) CLEANING OF DRAIN VALVES, GAS LINES, RINSE/WASH NOZZLES, STRAINERS, SCREENS, OR SPRAY PIPES; (5) CLEANING OR DELIMING OF THE DISHMACHINE OR ANY COMPONENT INCLUDING, BUT NOT LIMITED TO, WASH ARMS, RINSE ARMS AND STRAINERS; (6) CONDITIONS CAUSED BY THE USE OF INCORRECT (NON-COMMERCIAL) GRADE DETERGENTS; (7) CORROSION FROM CHEMICALS DISPENSED IN EXCESS OF RECOMMENDED CONCENTRATIONS; (8) COSMETIC DAMAGE, INCLUDING BUT NOT LIMITED TO, SCRATCHES, DENTS, CHIPS, AND OTHER DAMAGE TO THE DISHMACHINE FINISHES, UNLESS SUCH DAMAGE RESULTS FROM DEFECTS IN MATERIALS AND WORKMANSHIP AND IS REPORTED TO JACKSON WITHIN (30) THIRTY DAYS FROM THE DATE OF INSTALLATION; (9) DAMAGE CAUSED BY LABOR DISPUTE; (10) DAMAGES RESULTING FROM IMPROPER CONNECTION TO UTILITY SERVICE; (11) DAMAGES RESULTING FROM WATER CONDITIONS, INADEQUATE OR EXCESSIVE WATER PRESSURE, ACCIDENTS, ALTERATIONS, IMPROPER USE, ABUSE, HANDLING, OVERLOADS, TAMPERING, IMPROPER INSTALLATION OR FAILURE TO FOLLOW MAINTENANCE AND OPERATING PROCEDURES; (12) DISCOLORATION, RUST OR OXIDATION OF SURFACES RESULTING FROM CAUSTIC OR CORROSIVE ENVIRONMENTS, INCLUDING, BUT NOT LIMITED TO, HIGH SALT CONCENTRATIONS, HIGH MOISTURE OR HUMIDITY, OR EXPOSURE TO CHEMICALS; (13) ELECTRIC BOOSTERS, FEED LINES, FLEX HOSE, FUSES, GARBAGE DISPOSALS, OR GAS PILOTS; (14) EXCESSIVE LIME, MINERAL, OR ALKALINE BUILDUP; (15) EXPENSES DUE TO DISCONNECTION, DELIVERY, RETURN AND REINSTALLATION; (16) FAILURE OF ELECTRICAL COMPONENTS DUE TO CONNECTION OF CHEMICAL DISPENSING EQUIPMENT INSTALLED BY OTHERS; (17) FAILURE OF FACILITY WATER HEATER TO MAKE TEMPERATURE; (18) FAILURE TO MAINTAIN WATER HARDNESS LOWER THAN 3.0 GRAINS, PH BETWEEN 7.0 AND 8.5 AND TOTAL DISSOLVED SOLIDS BELOW 250 PPM; (19) FAILURE TO COMPLY WITH LOCAL ELECTRICAL BUILDING CODES; (20) LEAKS OR DAMAGE RESULTING FROM SUCH LEAKS CAUSED BY THE INSTALLER, INCLUDING THOSE AT MACHINE TABLE CONNECTIONS, OR BY CONNECTION OF CHEMICAL DISPENSING EQUIPMENT INSTALLED BY OTHERS; (21) OPENING OR CLOSING OF UTILITY SUPPLY VALVES OR SWITCHING OF ELECTRICAL SUPPLY CURRENT; (22) PERFORMANCE OF REGULAR MAINTENANCE AND CLEANING AS OUTLINED IN THE OPERATOR'S GUIDE; (23) REMOVAL OR REINSTALLATION OF INACCESSIBLE DISHMACHINES OR BUILT-IN FIXTURES THAT INTERFERE WITH SERVICING, REMOVAL OR REPLACEMENT OF THE DISHMACHINE; (24) REPLACEMENT WEAR ITEMS INCLUDING, BUT NOT LIMITED TO, CURTAINS, DRAIN BALLS, DOOR GUIDES, GASKETS, O-RINGS, SEALS, SQUEEZE TUBES, AND BEARINGS; (25) RESIDENTIAL USE; (26) USE WITH UTILITY SERVICE OTHER THAN THAT DESIGNATED ON THE RATING PLATE.

REVISION HISTORY

Revision	Date	Made by	Process	Details
F	6-1-04	MAW	N/A	Change to new layout.
G	1-5-05	MAW	N/A	Corrected amerate ratings, changed to thermostat bracket 05700-011-81-64, changed thermostat 05930-121-71-29 to thermostat kit 06401-140-00-32, updated drawing for false panel installation, and added SDI override instructions.
H	1-17-06	MAW	7609	Added universal timer, parts, and schematics.
I	7-6-06	MAW	7713 7571 7493 7553 7411 7422 7231	Updated specification & dimension pages. Updated drain quench assembly. Replaced door switch 05930-003-02-20 with 05930-003-05-84. Added false panel kit numbers, door component kits. Replaced ball stop components. Replaced thermostat 05930-121-71-29 with 05930-510-03-79. Added the wash & rinse thermometer decals.
J	9-14-07	MAW		Obsoleted I/O manual, added warranty & repair centers. Listed minimum cycle times. Added Top-mount Control Box: dimensions, hood weldment, control box, and schematics. Corrected the rinse tank cover number, updated the cantilever support bracket and reed switch numbers.
K	10-8-08	ARL	7990	Added hi-limit thermostat setpoint instructions.
L	1-10-13	RLC	8252	Updated schematic and control box to reflect rotary switch.
M	3-7-13	RLC	QOF NDB-219	Updated Jackson logo and company name.
N	3-24-14	MHH		Updated warranty page. Removed "Stop" page. Converted manual from Quark to InDesign.
O	4-16-14	MHH	8291	Changed pgs. 22, 25, 28, and 31.
P	6-4-14	MHH	8287	New P/N for bearing on rinse arm assembly, pg. 41.
Q	10-28-14	KAP	8298	Updated pgs. 4, 5, and 23 to accommodate new door and new Cantilever Arm.
R	12-1-14	KAP	N/A	Updated assembly numbers on pg. 31.
S	4-6-15	KAP	N/A	Inserted note pertaining to corner installation pg. 6.
T	4-7-15	KAP	8329	Added Tempstar HH, NB 208-230 V, 60 Hz, 1-phase on pg. 54.
U	6-11-15	KAP	N/A	Added Tempstar HH LT and Tempstar HH Ventless components. Updated solid state schematics on pgs. 60 and 61. Added NB/LT Schematic on page 69. Updated 208-230 V, 60 Hz on page 65. Updated Plumbing Assemblies pg. 46
V	6-25-15	KAP	N/A	Updated schematics on pgs. 64 and 66.
-	7-13-15	KAP	N/A	Added Ventless heater ratings on pg. 2.
-	9-18-15	KAP	N/A	Updated Rinse Heater Ratings for 208 V/60 Hz.
W	10-7-15	KAP	N/A	Added HH ventless booster tank assembly on pg. 42.
-	10-13-15	KAP	N/A	Updated P/N for solenoid valve on pg. 46 Changed P/N from 04820-002-01-32 to 04820-002-01-56.
X	11-9-15	JH	N/A	Corrected P/N for item 40 on pg. 37.
Y	11-23-15	JH	QOF-386	Replaced Plumbing Booster Inlet diagram, pg. 54.
Z	1-8-16	JH	N/A	Updated schematic on pg. 70.
AA	1-11-16	JH	QOF-386	Changed item 12 on pg. 39 to 05700-003-07-76. Added 05700-004-23-78, 05700-004-23-79, and 05700-004-23-80 to view (pg. 35) and parts list (pg. 36). Corrected Typical Electrical Circuits for TempStar HH Ventless.
AB	5-7-17	JH	N/A	Removed views that showed pressure regulator in certain locations. Added pressure regulator as an option. Added: exploded view and parts list for Motor & Pump Assembly, instructions on rinse arm maintenance to the Maintenance section, dimensions for the corner table notch to the Table Dimensions page, Plumbing Options page, dispenser connections decal for 460 V machine, instructional pictures where appropriate, external device wiring instructions as an Addendum, and instructions for programming new exhaust fan timer. Changed name of delime switch throughout from NORMAL/DELIME to AUTO/MANUAL. Updated schematics. Updated to new manual format. Audited and corrected all P/Ns in the manual.

REVISION HISTORY

Revision	Date	Made by	Process	Details
AC	9-9-17	JH	8541 8543	Added the TempStar HH-E and associated parts and assemblies. Moved door switch from the Tub Assembly page to the Hood Assembly page. Added door switch bracket assembly to the Hood Assembly page. Updated schematics on pgs. 76 and 77.
AD	10-16-18	JH	8392 8480 8533 8536 8558 8567 8576 8599	Replaced the HH Ventless with HH-E-VER. Replaced the HH NB with HH-E NB. Changed steam pressure to 10-30 PSI on pg. 5. Updated electrical requirements on pgs. 6-7. Added links to exhaust fan timer instructions to pg. 9. Added Chemical Connections section to pg. 10. Added Motor Rotation section to pg. 11. Added False Panel/Corner Install section to pg. 12. Added new exhaust fan timer to pgs. 23 and 25. Changed P/N for contactor, item #4 on pg. 24. Updated pgs. 28-29 with new door and arm assembly. Replaced thermostat and components with solid state thermostat and components pgs. 30-34. Added page for new rinse tank on pg. 36. Updated P/Ns on pg. 37. Added new phase conversion kit P/N to pg. 41. Updated plumbing on pgs. 42-45. Changed rinse arm bearing assembly on pgs. 50-51. Changed rinse arm bearing kit P/N on pg. 51. Updated pg. 52-53 with new view and parts list. Added list of applicable kits to pg. 57. Updated schematics.
AE	8-16-21	JH	N/A	Updated cycle times. Added resistance-to-temperature table to Preventative Maintenance section. Updated wash arm P/Ns. Added door glide P/N to Door & Arm page. Corrected sump strainer P/N. Changed reference to 460 V parts on Control Box page. Changed P/N of gauge on VER System page.
AF	9-1-22	JH	8748 8849	Added power supply and relay to Control Box pages (used on machines with door interlock and VER machines with DC fans). Added DC fan to VER System pages with note on models affected. Updated applicable schematics to show AC and DC fans.
AG	8-31-23	JH	22-1424	Added: P/Ns where missing, scaltrol graphic, thermistor and union to booster, new door interlock, and links to previous revisions (LLC vs. float). Updated: latent and sensible heat values, note on VER fan, several P/Ns, and schematics.

Jackson[®]

Warewashing Systems

TempStar[®] HH-E

Door-type dishmachine; ENERGY STAR[®] qualified, electrically-heated, high-temp, hot-water sanitizing, with booster heater.

TempStar[®] HH-E-VER

Door-type dishmachine; ENERGY STAR[®] qualified, electrically-heated, high-temp, hot-water sanitizing, with booster heater and ventless energy recovery system.

TempStar[®] HH-E NB

Door-type dishmachine; electrically-heated, high-temp, hot-water sanitizing, no rinse booster.

TempStar[®] HH S

Door-type dishmachine; steam-heated, high-temp, hot-water sanitizing.

The manufacturer provides technical support for all of the machines detailed in this manual. We strongly recommend that you refer to this manual before making a call to our technical support staff. Please have this manual open when you call so that our staff can refer you, if necessary, to the proper page. Technical support is not available on holidays.

Contact technical support toll free at 1-888-800-5672.

Technical support is available for service personnel only.

TABLE OF CONTENTS

GUIDES

Symbols.....	1
Abbreviations & Acronyms	1

SPECIFICATIONS

Dimensions.....	2
Dimensions - HH-E-VER	3
Table Dimensions	4
Operating Parameters	5
Electrical Requirements	6

INSTALLATION

Installation Instructions.....	8
<i>Inspection</i>	8
<i>Unpacking</i>	8
<i>VER Assembly</i>	8
<i>Leveling</i>	12
<i>Plumbing</i>	12
<i>Water Supply Connection</i>	12
<i>Steam Line Connection</i>	13
<i>Pressure Regulator</i>	13
<i>Shock Absorber</i>	13
<i>Connecting the Drain Line</i>	13
<i>Exhaust Fan Timer</i>	13
<i>Chemical Connections</i>	14
<i>Plumbing Check</i>	14
<i>Electrical Power Connections</i>	15
<i>Motor Rotation</i>	15
<i>Voltage Check</i>	16
<i>Surrounding Area</i>	16
<i>Temperature Setpoints</i>	16
<i>False Panel/Corner Install</i>	16
<i>Facility Hot Water Heater</i>	16

TABLE OF CONTENTS

OPERATION

Operating Instructions	17
<i>Preparation</i>	17
<i>Power Up</i>	17
<i>Filling the Wash Tub</i>	17
<i>Ware Preparation</i>	17
<i>Daily Machine Preparation</i>	17
<i>Warm-up Cycles</i>	18
<i>Washing a Rack of Ware</i>	18
<i>Operational Inspection</i>	18
<i>Shutdown & Cleaning</i>	18
<i>VER Coil Cleaning</i>	20
<i>Detergent Control</i>	21
<i>Deliming</i>	22

MAINTENANCE

Preventative Maintenance	23
--------------------------------	----

TROUBLESHOOTING

Troubleshooting.....	24
----------------------	----

PARTS

Control Box.....	26
Hood.....	30
Door & Arm.....	32
Tub	34
Steam Tub	37
Frame	39
Rinse Tank	40
Steam Coil	41
Motors	42
Heaters.....	44
Plumbing - HH-E	45
Plumbing - HH-E-VER.....	47
Inlet Plumbing - HH S	49
Outlet Plumbing - HH S	50
Plumbing Options	51

PARTS

Solenoid Valve & Vacuum Breaker Parts	52
Wash & Rinse Assemblies.....	53
VER System.....	55
VER Door Interlock.....	57
VER Door Interlock Override.....	59
460 V Machine Transformer Mounting Box.....	60
Kits	61

SCHEMATICS

208/230 V, 50/60 HZ, 1/3 PH.....	62
460 V, 60 HZ, 3 PH.....	63
HH S 208/230 V	64
SDI Options	65

SYMBOLS



- Risk of injury to personnel



- Risk of damage to equipment



- Risk of electrical shock



- Caustic chemicals



- Reference data plate



- Lockout electrical power

NOTICE - Important note



- Instructions hyperlink

ABBREVIATIONS & ACRONYMS

ANSI - American National Standards Institute

Btu/Hr - British Thermal Units per Hour

CFM - Cubic Feet per Minute

GHT - Garden Hose Thread

GPH - Gallons per Hour

GPM - Gallons per Minute

GPG - Grains per Gallon

HP - Horsepower

Hz - Hertz

ID - Inside Diameter

kW - Kilowatts

MCA - Minimum Circuit Ampacity

MOP - Maximum Overcurrent Protection

NFPA - National Fire Protection Association

NPT - National Pipe Thread

OD - Outside Diameter

PRV - Pressure Regulating Valve

PSI - Pounds per Square Inch

V - Volts

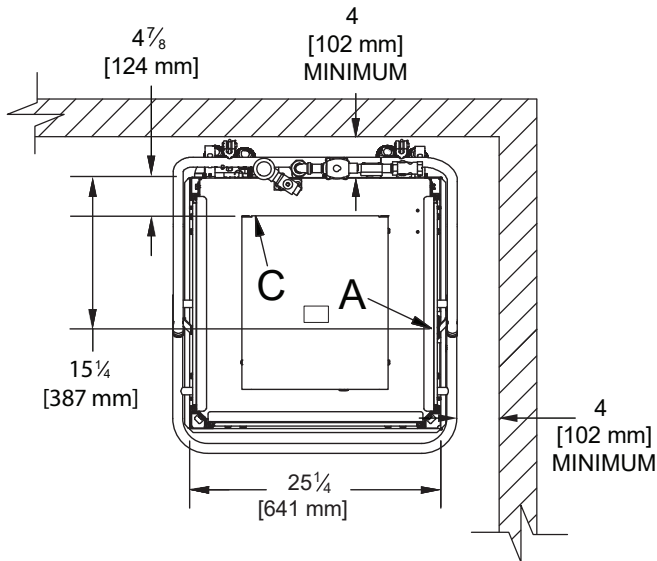

LEGEND

- A - Drain 1 1/2" NPT
- B - Water Inlet 1/2" NPT
- C - Electrical Connection
- D - Optional Steam Connection 3/4" NPT

All dimensions from the floor can be increased 1 1/8" using the machine's adjustable feet.

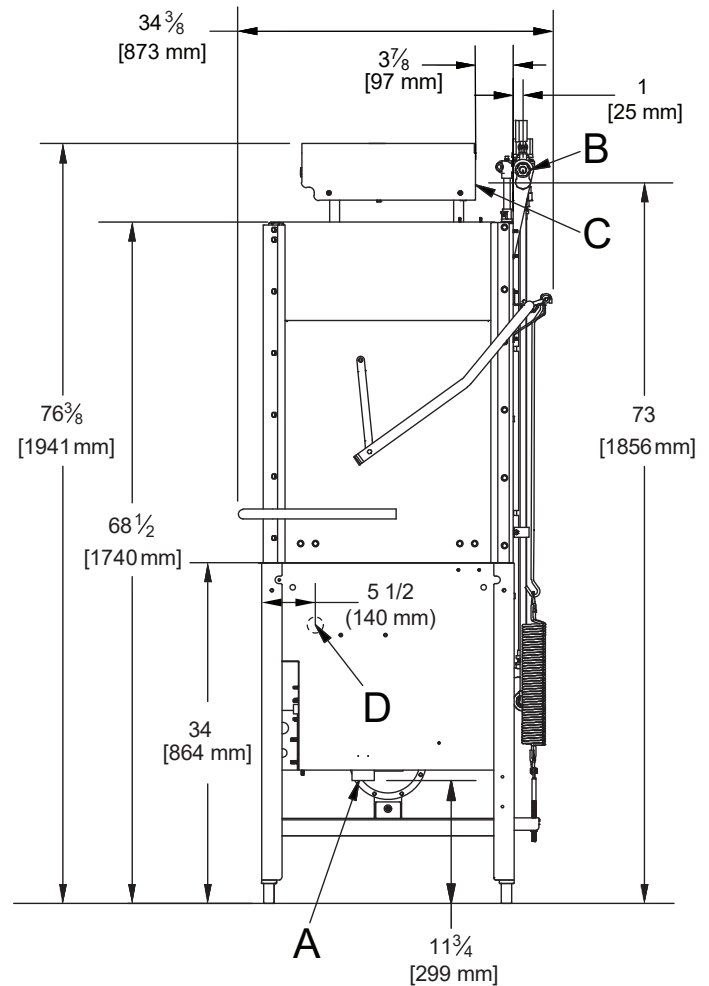
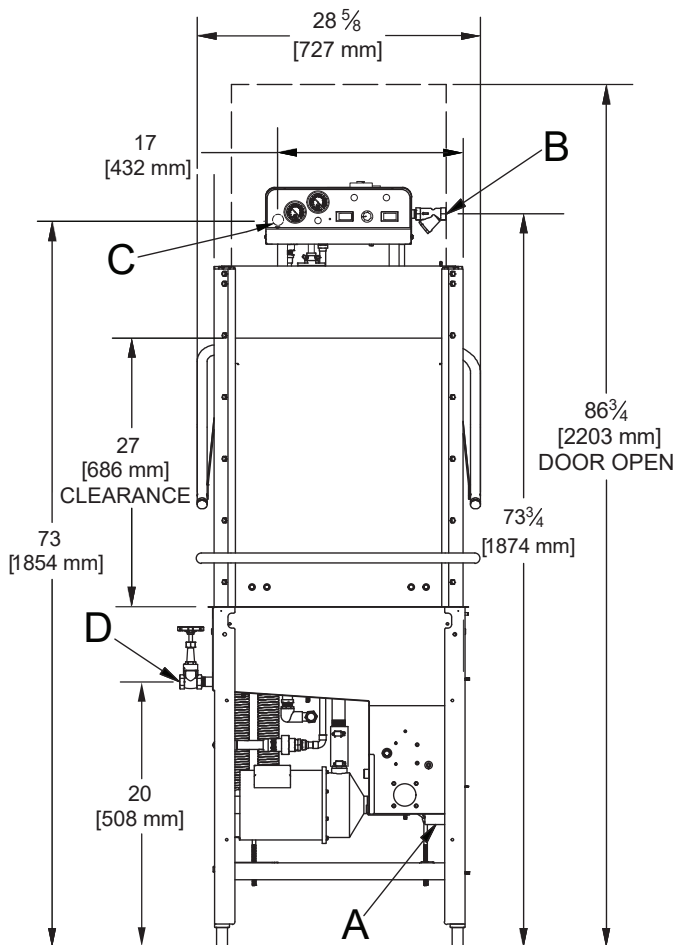

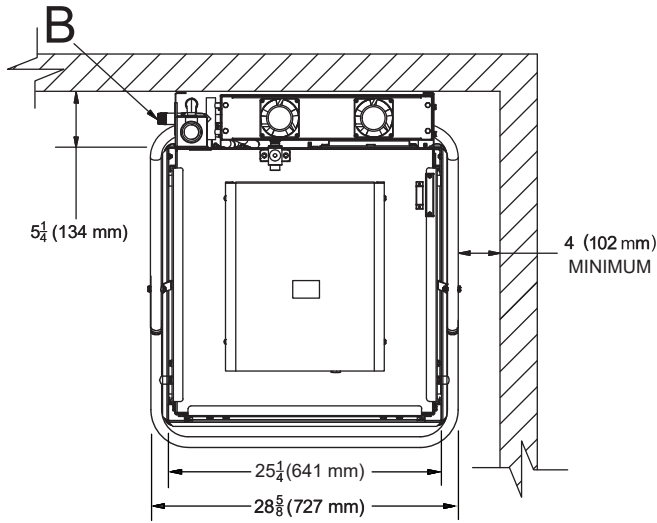

LEGEND

- A - Drain 1 1/2" NPT
- B - Water Inlet 3/4" NPT
- C - Electrical Connection

All dimensions from the floor can be increased 1 1/8" using the machine's adjustable feet.

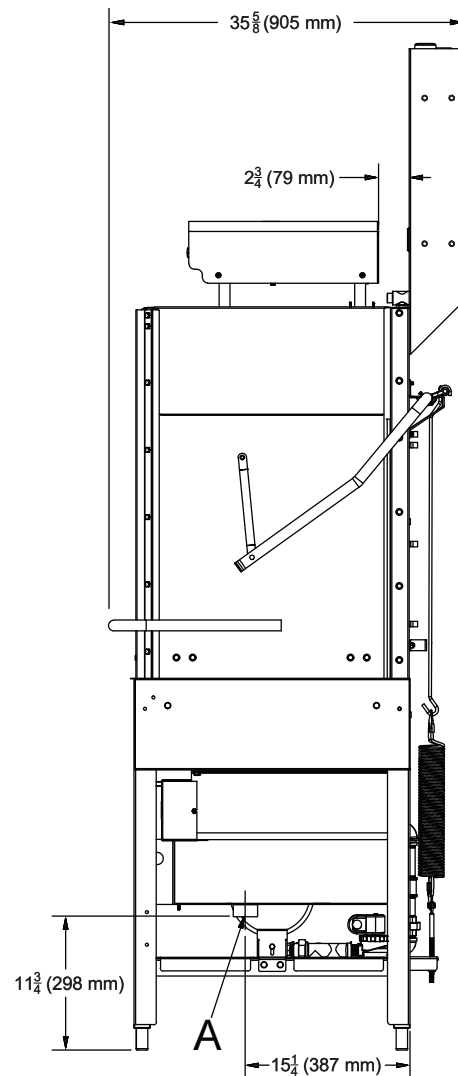
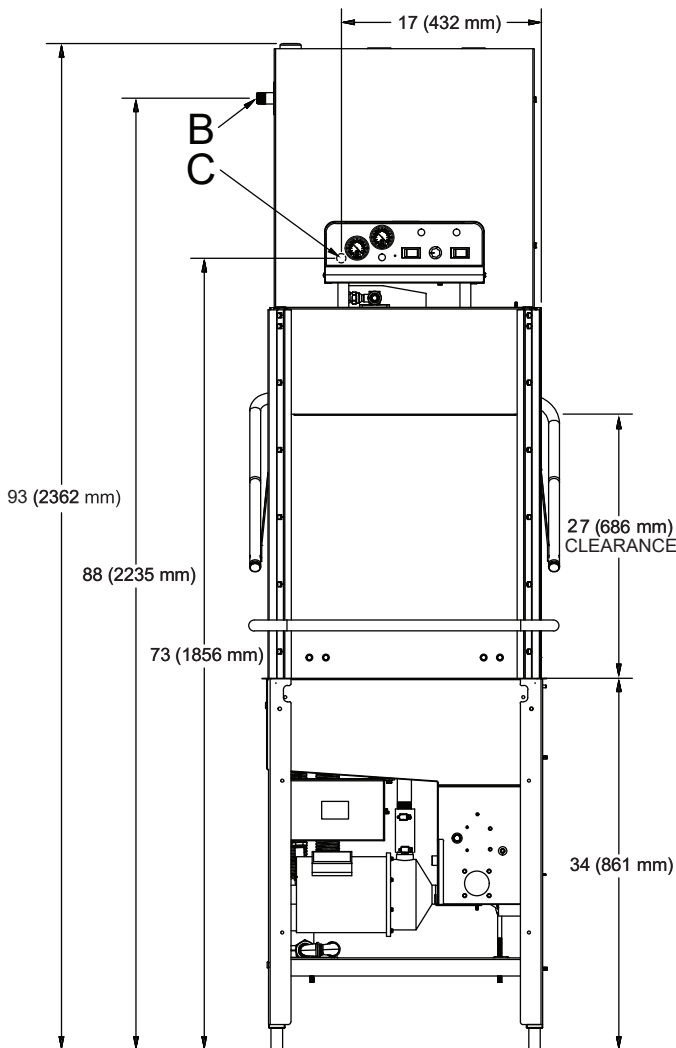

CORNER INSTALLATION

For corner install instructions:

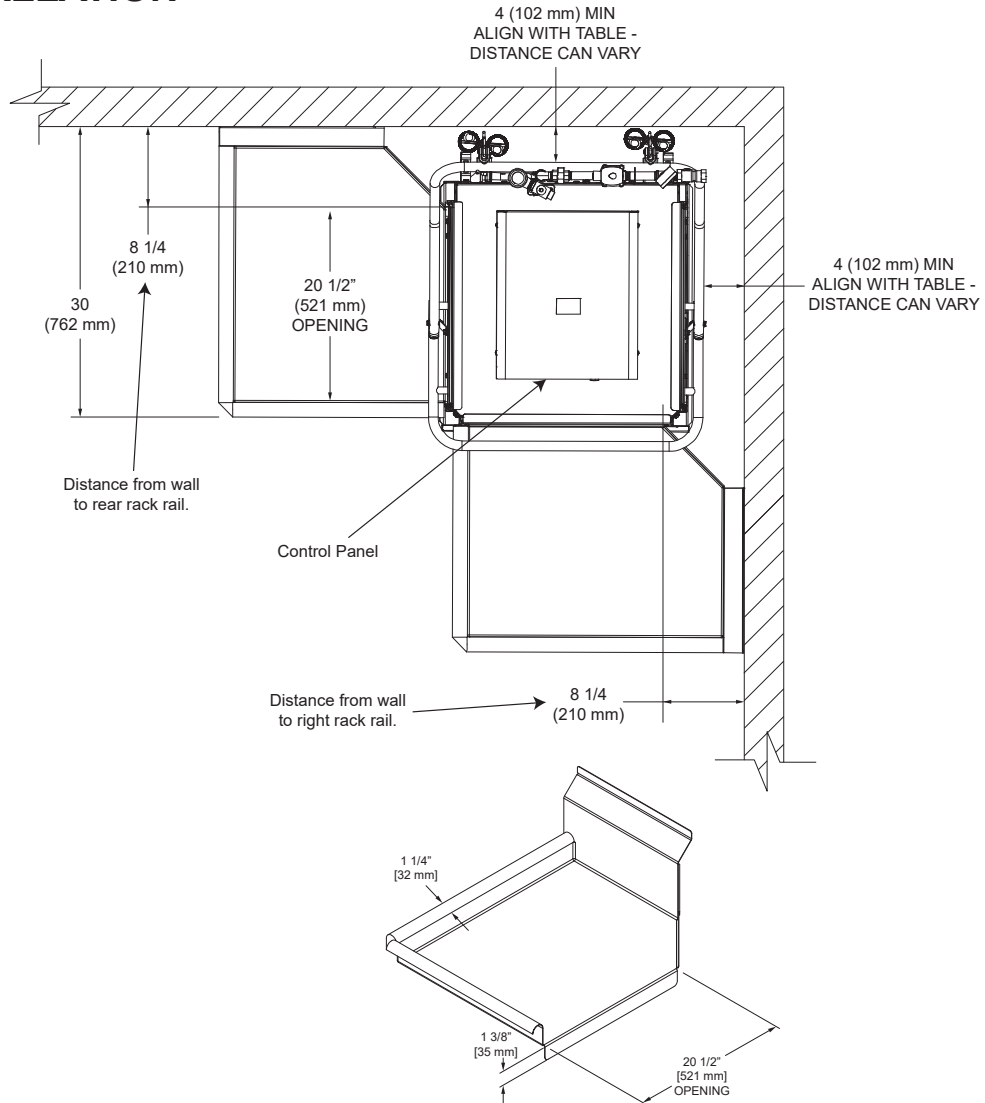

STRAIGHT-THROUGH INSTALLATION

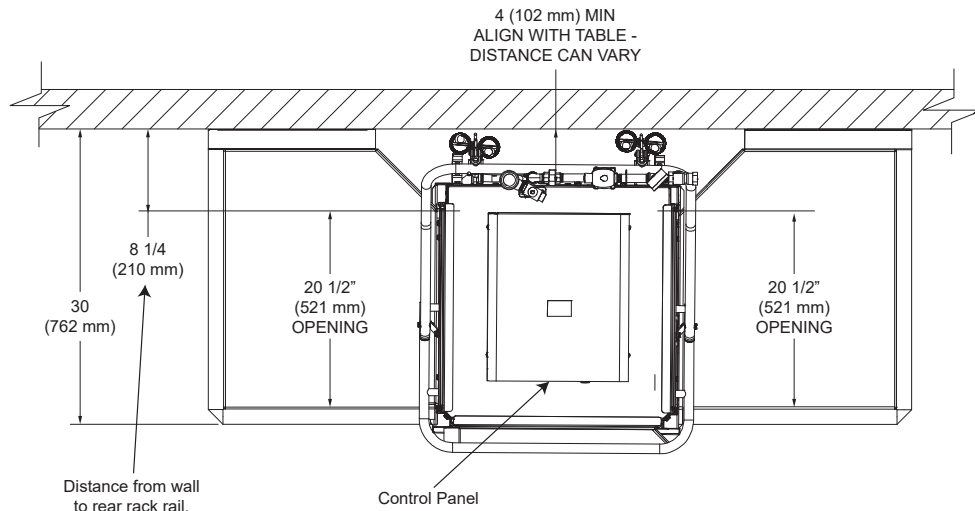

SPECIFICATIONS

OPERATING PARAMETERS

OPERATING CYCLES (SECONDS):

HH-E/NB

	Wash	Rinse	Dwell	Total
Normal	40	10	10	60
Medium	103	10	10	123
Heavy	163	10	10	183
Extra-Heavy	283	10	10	303

HH-E-VER

	Wash	Rinse	Dwell	VER	Total
Normal	40	10	7	30	87
Medium	100	10	7	30	147
Heavy	160	10	7	30	207
Extra-Heavy	280	10	7	30	327

OPERATING CAPACITY:

Normal Cycle

Racks per Hour	60*
Dishes per Hour	1500
Glasses per Hour	2160

Medium Cycle

Racks per Hour	29
Dishes per Hour	725
Glasses per Hour	1044

Heavy Cycle

Racks per Hour	19
Dishes per Hour	475
Glasses per Hour	684

Extra-heavy Cycle

Racks per Hour	11
Dishes per Hour	275
Glasses per Hour	396

TANK CAPACITY:

Rinse Tank (gallons/liters)	3.0/11.4
Wash Tank (gallons/liters)	8.0/30.3

MOTOR HP:

Wash Motor HP	2.0
---------------	-----

WATER REQUIREMENTS:

HH-E:

Wash Temperature (minimum) (°F/°C)	155/68
Rinse Temperature (minimum) (°F/°C)	180/83
Inlet Water Temperature (°F/°C)	
12 kW Rinse Heater (°F/°C)	140/60
14 kW Rinse Heater (°F/°C)	110/44
Flow Pressure (PSI)	10 ± 2
Water Line Size (NPT)	1/2"
Drain Line Size (NPT)	1 1/2"

HH-E-VER:

Wash Temperature (minimum) (°F/°C)	155/68
Rinse Temperature (minimum) (°F/°C)	180/83
Inlet Water Temperature (°F/°C)	40-90/4.4-32.2
Flow Pressure (PSI)	10 ± 2
Water Line Size (NPT)	3/4"
Drain Line Size (NPT)	1 1/2"

NB/HH S:

Wash Temperature (minimum) (°F/°C)	150/66
Rinse Temperature (minimum) (°F/°C)	180/83
Inlet Water Temperature (°F/°C)	180/83
Flow Pressure (PSI)	20 ± 5
Water Line Size (NPT)	3/4"
Drain Line Size (NPT)	1 1/2"

HH S STEAM REQUIREMENTS:

Coil Size	3/4"
Steam Flow Pressure (PSI)	10-30
Consumption @ 15 PSI (lbs/hr)	45

ENERGY SPECIFICATIONS

HH-E-VER

Latent Heat	10343 Btu/Hr
Sensible Heat	5968 Btu/Hr

*Racks per hour calculated without NSF suggested load time of five seconds for door-types.

NOTICE



Always refer to the machine data plate for specific electrical and water requirements.
The material provided on this page is for reference only and is subject to change without notice.

Local codes may require more stringent protection than what is displayed here. Always verify with your electrical service contractor that your circuit protection is adequate and meets all applicable national and local codes. Numbers in this manual are for reference and may change without notice.

NOTICE

On three-phase machines, imbalanced wild leg goes to L3.
Also see the Motor Rotation section.



TEMPSTAR HH-E 70° Rise (14 kW) & TEMPSTAR HH-E-VER

Volts	Phase	Freq	Wash Motor	Wash Heater	Rinse Heater	Total Load	MCA	MOP
208	1	60 Hz	11.2 A	19.7 A	50.6 A	81.5 A	84.3 A	95.0 A
230	1	60 Hz	11.2 A	21.8 A	55.9 A	88.9 A	91.7 A	100.0 A
208	3	60 Hz	11.2 A	11.4 A	29.2 A	51.8 A	54.6 A	65.0 A
230	3	60 Hz	11.2 A	12.6 A	32.3 A	56.1 A	58.9 A	70.0 A
460	3	60 Hz	3.0 A	6.3 A	16.1 A	25.4 A	26.2 A	30.0 A



TEMPSTAR HH-E 40° Rise (12 kW)

Volts	Phase	Freq	Wash Motor	Wash Heater	Rinse Heater	Total Load	MCA	MOP
208	1	60 Hz	11.2 A	19.7 A	43.3 A	74.2 A	77.0 A	85.0 A
230	1	60 Hz	11.2 A	21.8 A	47.9 A	80.9 A	83.7 A	90.0 A
208	3	60 Hz	11.2 A	11.4 A	25.0 A	47.6 A	50.4 A	60.0 A
230	3	60 Hz	11.2 A	12.6 A	27.7 A	51.5 A	54.3 A	65.0 A
460	3	60 Hz	3.0 A	6.3 A	13.8 A	23.1 A	23.9 A	25.0 A

Local codes may require more stringent protection than what is displayed here. Always verify with your electrical service contractor that your circuit protection is adequate and meets all applicable national and local codes. Numbers in this manual are for reference and may change without notice.

NOTICE

On three-phase machines, imbalanced wild leg goes to L3.
Also see the Motor Rotation section.



TEMPSTAR HH-E NB

Volts	Phase	Freq	Wash Motor	Wash Heater	Rinse Heater	Total Load	MCA	MOP
208	1	60 Hz	11.2 A	19.7 A	N/A	30.9 A	33.7 A	40.0 A
230	1	60 Hz	11.2 A	21.8 A	N/A	33.0 A	35.8 A	45.0 A
208	3	60 Hz	11.2 A	11.4 A	N/A	22.6 A	25.4 A	35.0 A
230	3	60 Hz	11.2 A	12.6 A	N/A	23.8 A	26.6 A	35.0 A
460	3	60 Hz	3.0 A	6.3 A	N/A	9.3 A	10.1 A	15.0 A



TEMPSTAR HH S

Volts	Phase	Freq	Wash Motor	Wash Heater	Rinse Heater	Total Load	MCA	MOP
208	1	60 Hz	11.2 A	N/A	N/A	11.2 A	14.0 A	25.0 A
230	1	60 Hz	11.2 A	N/A	N/A	11.2 A	14.0 A	25.0 A
208	3	60 Hz	11.2 A	N/A	N/A	11.2 A	14.0 A	25.0 A
230	3	60 Hz	11.2 A	N/A	N/A	11.2 A	14.0 A	25.0 A
460	3	60 Hz	3.0 A	N/A	N/A	3.0 A	3.8 A	15.0 A

INSPECTION

Before installing the unit, check the packaging and machine for damage. If the packaging is damaged, the machine might also be damaged. If there is damage to both packaging and machine, do not throw away the packaging. The machine has been inspected and packed at the factory and is expected to arrive to you in new, undamaged condition. However, rough handling by carriers or others might result in damage to the unit while in transit. If so, do not return the unit to the manufacturer. Instead, contact the carrier and ask them to send a representative to the site to inspect the damage and complete an inspection report. You must contact the carrier and the dealer that sold you the unit within 48 hours of receiving the machine.

Do not throw away packaging if damage is evident!

UNPACKING

While unpacking the machine, ensure that there are no missing parts. If an item is missing, contact the manufacturer immediately.

VER SYSTEM ASSEMBLY

1. Ensure hoses are connected to VER system.

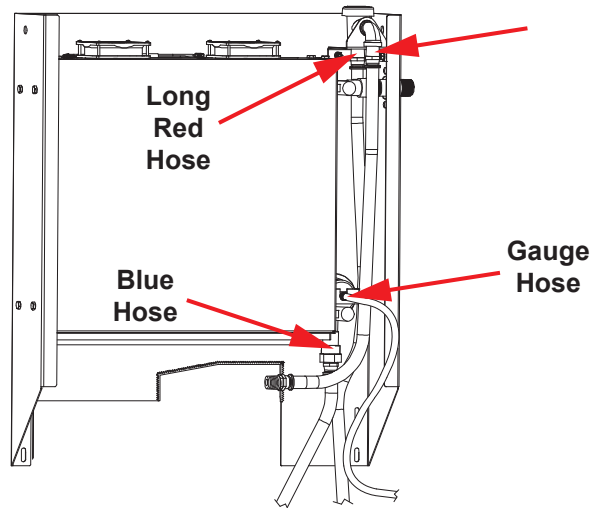

2. Locate bag inside the machine with four 1/4-20 bolts. These secure VER system to the machine.

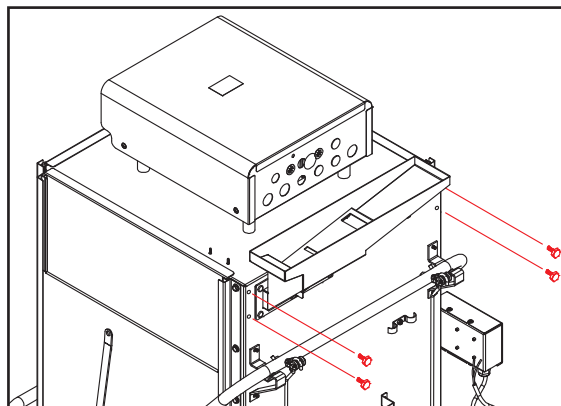

Locate bolts in bag inside the machine.

VER SYSTEM ASSEMBLY

- Lift VER system up and over lower air inlet, then align and slide into lower air inlet. VER system slides inside lower air inlet at the seam.



WARNING! Use proper lifting techniques or use a lifting aid.

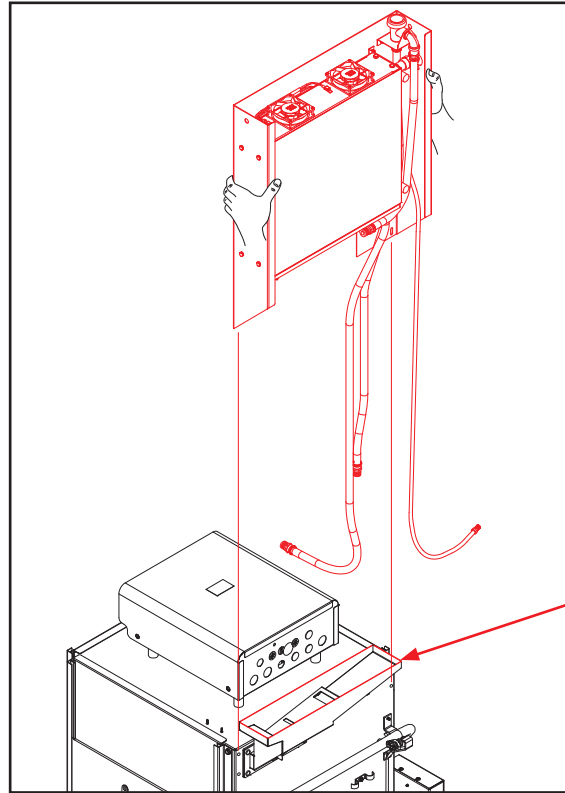

Lower Air Inlet Seam

- Install four 1/4-20 bolts located in Step 1 with 7/16 wrench.

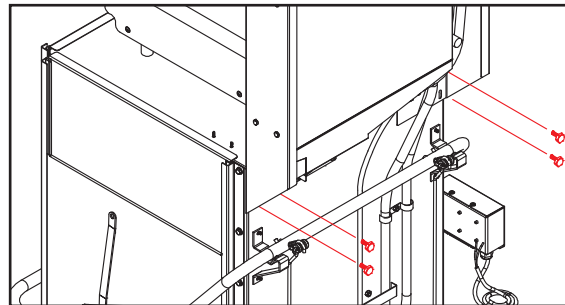

7/16 wrench used in this step.

Bolts located in Step 1 used in this step.

- Use 9/16 wrench to connect gauge hose to side of tee on plumbing from booster.

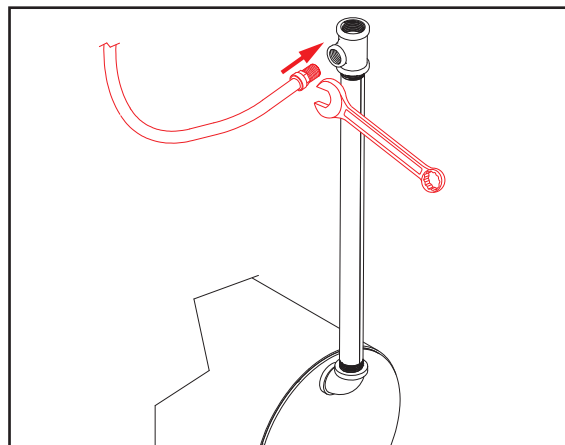

9/16 wrench used in this step.

Apply thread tape to threads of hose before connecting.

Hose is cut-to-length and will only reach intended connection point.

VER SYSTEM ASSEMBLY

- Use adjustable wrench to connect long red hose to top of tee on plumbing from booster.

Adjustable wrench used in this step.

Apply thread tape to threads of hose before connecting.

Hose is cut-to-length and will only reach intended connection point.

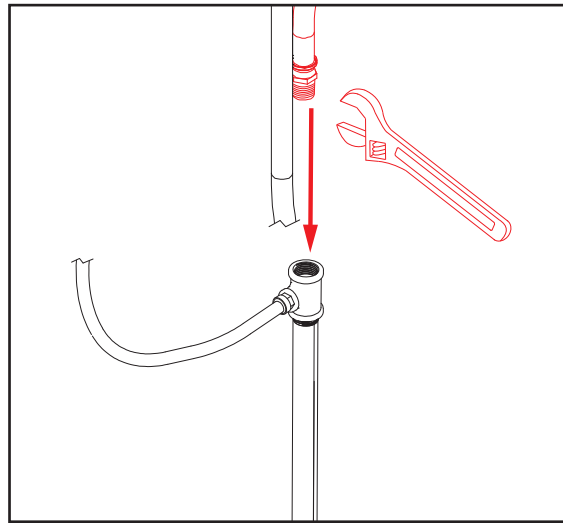

- Use adjustable wrench to connect short red hose to rinse injector.

Adjustable wrench used in this step.

Apply thread tape to threads of hose before connecting.

Hose is cut-to-length and will only reach intended connection point.

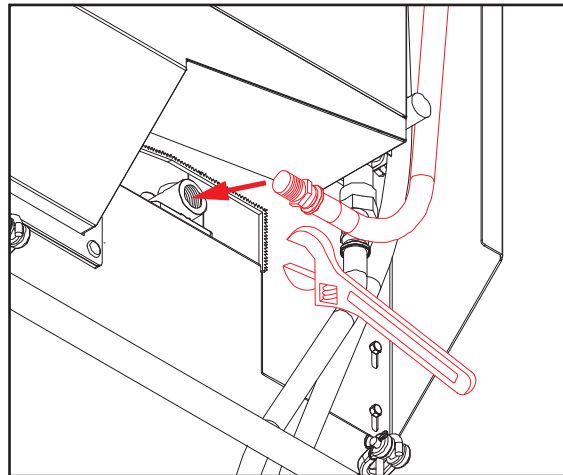

- Use adjustable wrench to connect blue hose to coupling on plumbing going to booster.

Adjustable wrench used in this step.

Apply thread tape to threads of hose before connecting.

Hose is cut-to-length and will only reach intended connection point.

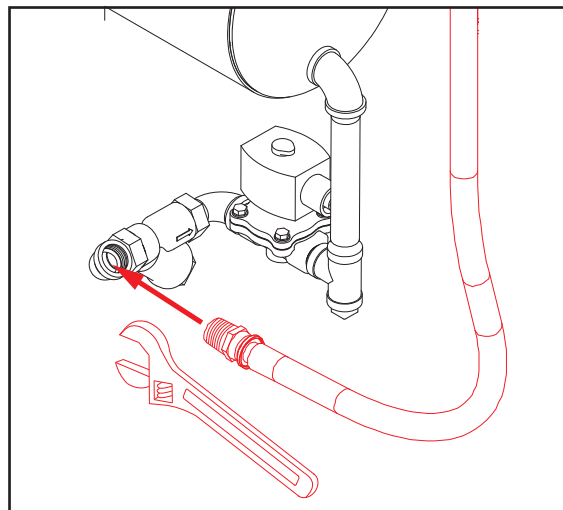

VER SYSTEM ASSEMBLY

9. Tidy hoses by sliding them under clamps.

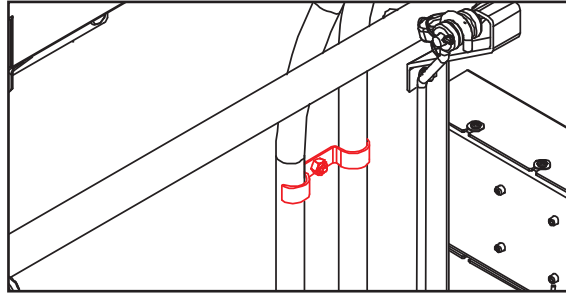

10. Locate wire connectors at top of VER system (near fans) and connect black wire and white wire from machine control box (located in black cord routed from control box), black in one connector and white in the other.

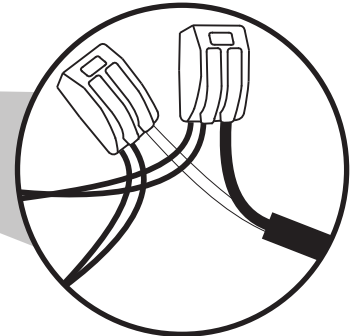
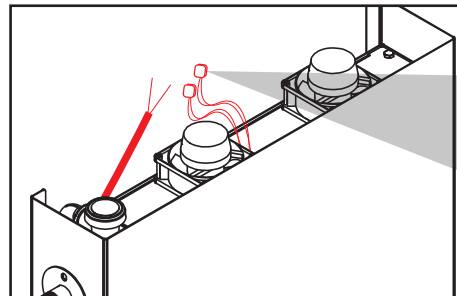

11. Tidy wires and lock them in place with p-clamp on top of VER system.

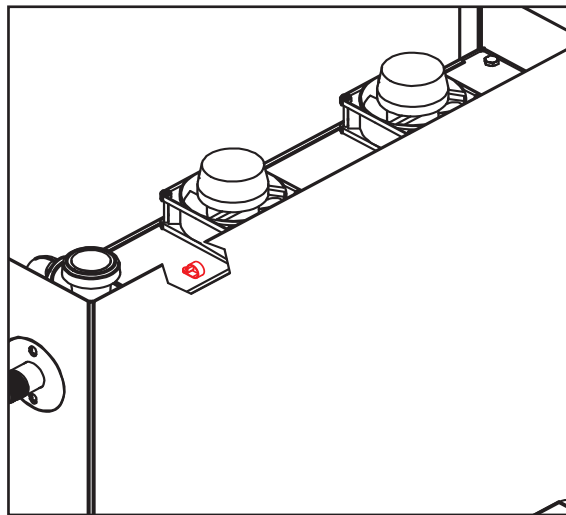

12. VER system is now assembled.

Black wire and white wire are shipped disconnected on end shown, but are already connected inside control box.



CAUTION! Fan wires must be connected to black wire and white wire before proceeding with machine installation!

LEVELING The machine must be level in its operating location to prevent damage to the machine during operation and to ensure best results. The machine comes with four adjustable bullet feet, which can be turned using a pair of channel locks (or by hand if the machine can be raised safely). Ensure that the machine is level from side-to-side and front-to-back before making any connections.

PLUMBING Plumbing connections must comply with all applicable local, state, and national plumbing codes. The plumber is responsible for ensuring the incoming water line is thoroughly flushed before connecting it to any component of the machine. It is very important to remove all foreign debris from the water line that might potentially get trapped in the valves or cause an obstruction. Any valves that are fouled as a result of foreign matter left in the water line—and any expenses resulting from this fouling—are not the responsibility of the manufacturer.

Plumber MUST flush the incoming water line!

A water hardness test MUST be performed.

A water hardness test must be performed to determine if a water treatment system needs to be installed.

**WATER SUPPLY CONNECTION:
WATER HARDNESS GREATER THAN 3 GPG**

If water hardness tests at greater than 3 GPG, install the Scaltrol Water Treatment system (see the Plumbing Options page) into the water line before the machine's incoming water connection point. A water shut-off valve should be installed to allow access for service.

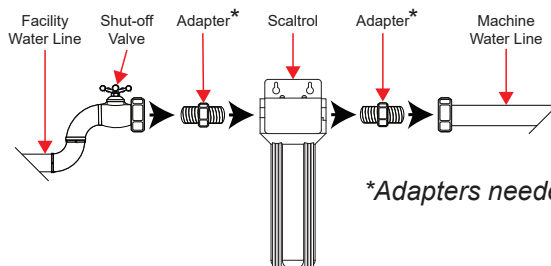

**WATER SUPPLY CONNECTION:
WATER HARDNESS LOWER THAN 3 GPG**

If water hardness tests at lower than 3 GPG, install the water supply line directly to the machine's incoming water connection point. A water shut-off valve should be installed to allow access for service.

STEAM LINE CONNECTION



The steam machines come with lines to connect the source steam. Connect all steam lines to the machine as all applicable codes provide. See machine data plate for information concerning steam flow pressure. Click [here](#) or on the instructions icon for the Steam Booster manual.

PRESSURE REGULATOR



The manufacturer recommends the installation of a water pressure regulator in the incoming water line to ensure proper flowrate at all times and offers these devices as options (see the Plumbing Options page). The PRV comes standard on the TempStar HH-E-VER but ships inside the machine. Click [here](#) for install instructions.

Do not confuse static pressure with flow pressure. Static pressure is the line pressure in a “no flow” condition (all valves and services are closed). Flow pressure is the pressure in the fill line when the fill valve is opened during the cycle.

SHOCK ABSORBER

The manufacturer also recommends the installation of a shock absorber in the incoming water line and offers these devices as options. This prevents line hammer/hydraulic shock—induced by the solenoid valve as it operates—from causing damage to the equipment (see the Plumbing Options page).

CONNECTING THE DRAIN LINE

The machine's drain is a gravity-discharge drain. All piping from the 1 1/2” NPT connection on the wash tank must be pitched (1/4” per foot) to the floor or sink drain. All piping from the machine to the drain must be a minimum 1 1/2” NPT and must not be reduced. There must also be an air-gap between the machine drain line and the floor sink or drain. If a grease trap is required by code, it should have a flow capacity of 5 GPM.

EXHAUST FAN TIMER

Determine which exhaust fan timer is on the machine (located in the control box) and click the instructions icon beside that timer to access programming instructions.

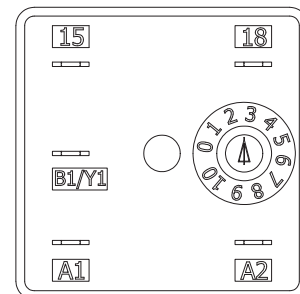
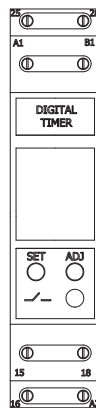

CHEMICAL CONNECTIONS

Detergent

Connect detergent by removing the bulkhead fitting on the back of the machine and replacing it with the appropriate dispensing equipment.

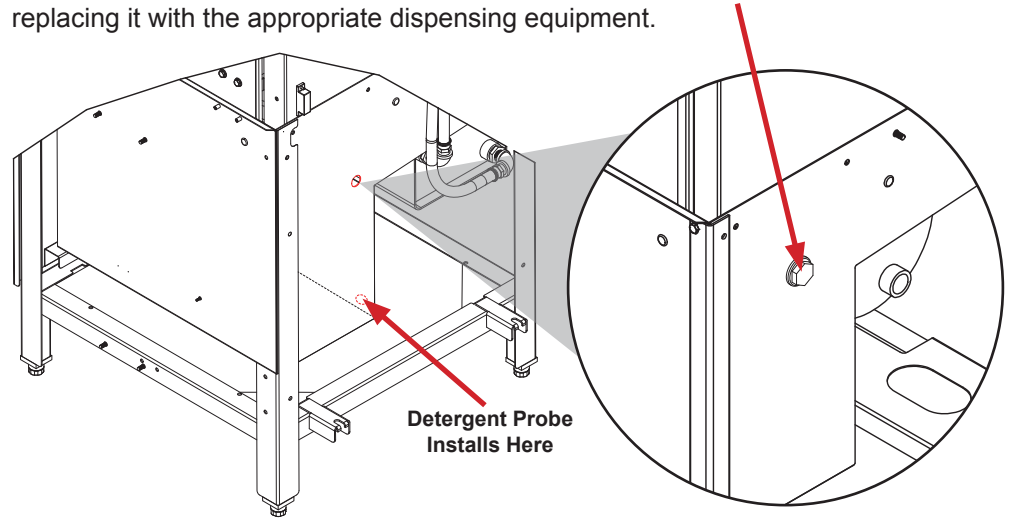

Rinse-aid

Connect rinse-aid by removing one of the brass plugs at the base of the rinse injector and replacing it with the appropriate dispensing equipment.

See "Plumbing - HH-E-VER" page for a depiction of the VER rinse injector.

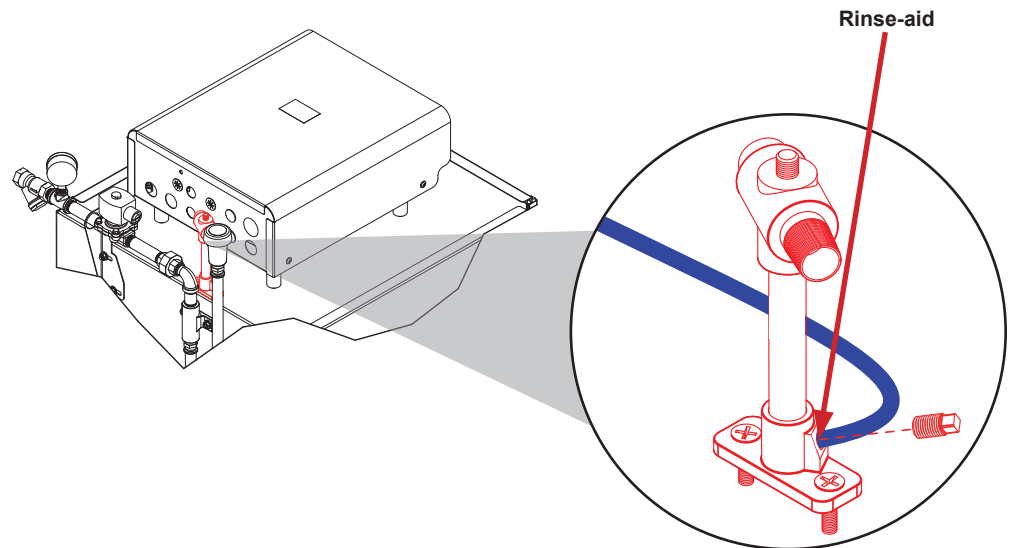

Dispenser Electrical Connections

The electrical connections for chemical dispensers are made on a fuse block inside the control box. Click [here](#) for a depiction of the fuse block and connection locations.

Chemical connections should be made by the chemical supplier.

Using deionized water or other aggressive fluids will result in corrosion and failure of components and will void the warranty.



WARNING! Some of the chemicals used in dishwashing may cause chemical burns if they come in contact with skin. Wear protective gear when handling these chemicals. If any skin comes in contact with these chemicals, immediately follow the instructions provided with the chemicals for treatment.



PLUMBING CHECK

Slowly turn on the water supply to the machine after the incoming fill line and drain line have been installed. Check for any leaks and repair as required. All leaks must be repaired before operating the machine.

ELECTRICAL POWER CONNECTIONS

Electrical and grounding conductors must comply with the applicable portions of the National Electric Code ANSI/NFPA 70 (latest edition) and/or other electrical codes.



Disconnect electrical power supplies and lockout/tagout in accordance with appropriate procedures and codes at the disconnect switch.

The data plate is located on the right side of the machine. Refer to the data plate for machine operating requirements, machine voltage, total amperage, and serial number.

1. Open the control box by using a phillips screwdriver to remove the four screws on the front cover of the control box.
2. Install 3/4" conduit into the pre-punched holes in the back of the control box.
3. Route power wires and connect to power block and grounding lug.
4. Install the service wires (L3 for 3-Phase only) to the appropriate terminals as they are marked on the terminal block.

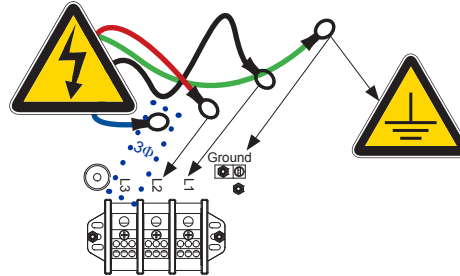

NOTICE
Imbalanced wild leg goes to L3.

5. Install the grounding wire into the lug provided.
6. Tighten the connections.

NOTICE "DE-OX" or similar anti-oxidation agent should be used on all power connections.

CAUTION! Improperly connecting external devices can cause damage to the machine and/or electrical infrastructure! Click [here](#) for a wiring guide.



MOTOR ROTATION

On 3-Phase machines only, correct pump motor rotation must be verified before the machine is operated. Failure to do so can result in damage to the machine and components.

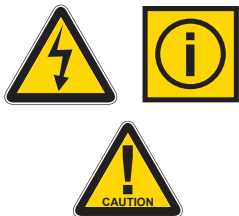

CAUTION! On 3-Phase machines only, correct pump motor rotation must be verified before operation!

1. Follow the "Filling the Wash Tub" section.
2. Locate the wash pump motor and identify the arrow decal which shows the correct motor rotation.

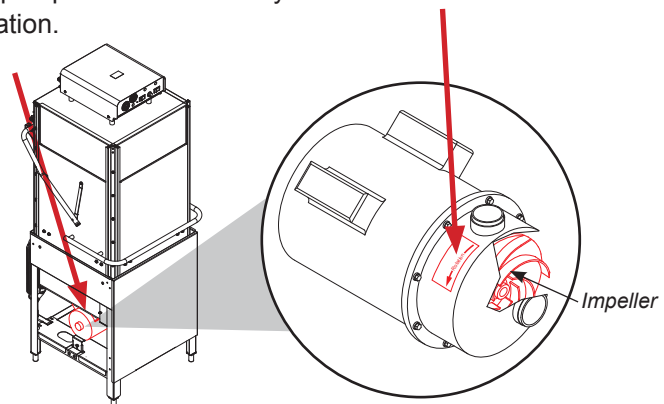

3. Flip the mode switch to "MANUAL" and start the machine.
4. Observe the rotation of impeller and quickly stop the machine.
5. If rotation is incorrect, disconnect electrical power and reverse the L1 and L2 connections at terminal block shown in the section above.

VOLTAGE CHECK

Ensure that the power switch is in the "OFF" position and apply power to machine. Check the incoming power at the terminal block and ensure it corresponds with the voltage listed on the data plate. If not, contact a qualified service agency to examine the problem. Do not run machine if voltage is too high or too low. Shut off the service breaker and advise all proper personnel of the location of the breaker and any problems. Replace the control box cover and tighten-down the screws.

SURROUNDING AREA

This is a commercial machine and reaches temperatures that can exceed those generated by a residential machine. Surrounding countertops, cabinets, flooring material, and subflooring material must be designed and/or selected with these higher temperatures in mind.

NOTICE Any damage to surrounding area caused by heat/moisture to materials that are not recommended for higher temperatures will not be covered under warranty or by the manufacturer.

TEMPERATURE SETPOINTS

The temperature setpoints on this unit have been set at the factory. They should only be adjusted by an authorized service agent.

**FALSE PANEL/
CORNER INSTALL**

The manufacturer offers an optional False Panel Kit for corner installations. See the Kits page for kit part number. Click [here](#) for false panel/corner install instructions.

FACILITY HOT WATER HEATER

The manufacturer does NOT endorse "Tankless On-demand" water heaters for use with their dishmachines. The manufacturer DOES endorse, and highly recommends, the standard "Tank" style water heaters, sized to properly handle the water heating requirements of the facility.

PREPARATION Before operating the unit, verify the following:

1. The tank is clean and free of debris.
2. The wash arms, rinse arms, sump strainer, and scrap screen are all installed correctly.
3. The standpipe is installed.

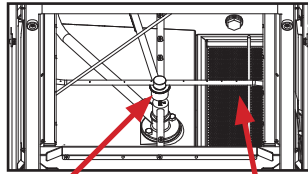

Wash & Rinse Arms, Scrap Screen

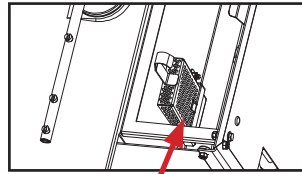

Sump Strainer

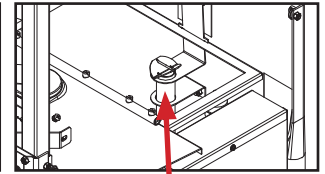

Standpipe

POWER UP To energize the unit, turn on the power at the service breaker. The voltage should have been previously verified as being correct. If not, the voltage will have to be verified.

FILLING THE WASH TUB Ensure that the mode switch is in the "AUTO" position, and place the power switch into the "ON" position. The machine will fill automatically and shut-off when the appropriate level is reached (just below the scrap screen). The wash tub must be completely filled before operating the wash pump to prevent damage to components. Once the wash tub is filled, the unit is ready for operation.

WARE PREPARATION Proper ware preparation will help ensure good results and fewer re-washes. If not prepared properly, ware might not come out clean and the efficiency of the machine will be reduced. Putting unscrapped dishes into the machine affects its performance, so scraps should always be removed from ware before being loaded into a rack. Pre-rinsing and pre-soaking are good ideas, especially for silverware and casserole dishes.

Place cups and glasses upside-down in racks so they don't hold water during the cycle. The machine sanitizes as well as cleans. To do this, ware must be properly prepared before being placed in the machine.

DAILY MACHINE PREPARATION Refer to the "Preparation" section and follow the instructions there. Afterward, ensure that chemicals are supplied to the machine. If not, contact your chemical supplier.

WARM-UP CYCLES

For the first operation of each day, it might be necessary to run the machine through three cycles to ensure that all of the cold water is out of the system and to verify that the unit is operating correctly. To cycle the machine, ensure that the power is on and that the tub has filled to the correct level. Lift and close the door and the cycle light will illuminate. The unit will start, run through the cycle, and shut-off automatically. Repeat this two more times. The unit should now be ready to wash a rack of ware.

WASHING A RACK OF WARE

To wash a rack, open the door completely (avoiding hot water that might drip from the door) and slide the rack into the unit.

Close the door and the unit will start automatically. Once the cycle is complete, open the door (again watching for the dripping hot water) and remove the rack of clean ware. Replace with a rack of soiled ware and close the door. Repeat this process.

OPERATIONAL INSPECTION

Based on use, the scrap screen might become clogged with soil and debris as the workday progresses. Operators should regularly inspect the scrap screen to ensure it has not become clogged. If clogged, it will reduce the washing capability of the machine. Instruct operators to clean-out the scrap screen at regular intervals or as required by workload. Do NOT beat strainers to remove debris.

SHUTDOWN & CLEANING

1. Turn machine off by flipping the power switch to "OFF."

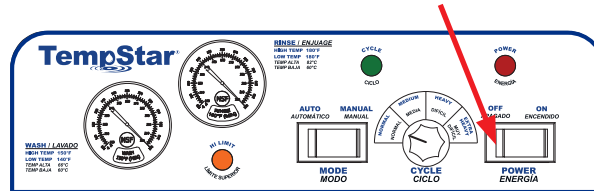

2. Open the door and allow steam/heat to escape.
3. Remove the standpipe and allow the tub to drain.

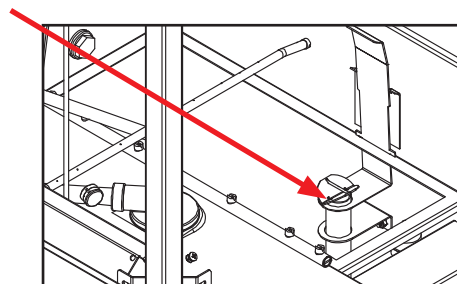

WARNING! Wash tank water will be hot!



**SHUTDOWN &
CLEANING**

4. Remove scrap screen and sump strainer.

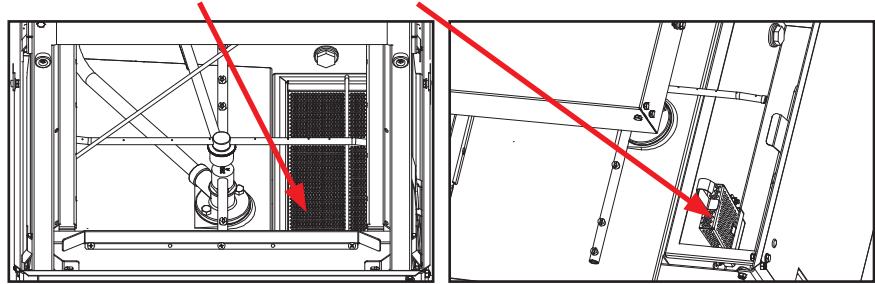

5. Use a hand-scraper to scrape foodsoil into a trash basket.

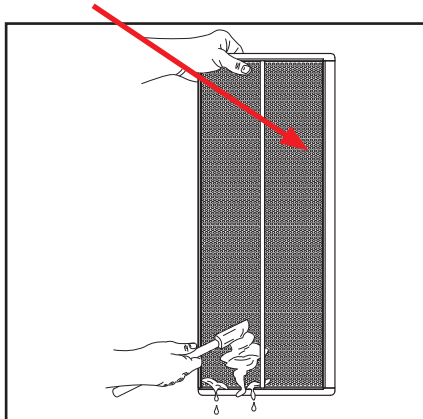

6. Rinse with pre-rinse hose and replace.

7. Remove all wash and rinse arms.

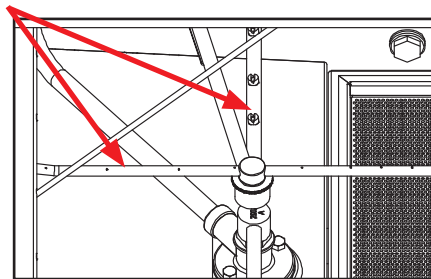

8. Remove end-caps from the arms.

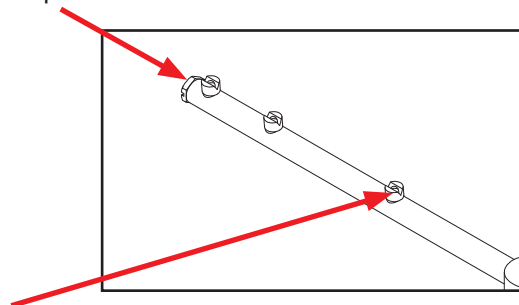

9. Clean nozzles with a brush.

10. Use a small wire or toothpick to remove remaining debris or lime deposits from nozzles.

11. Flush arms with water.

**SHUTDOWN &
CLEANING**

12. Replace end-caps and ensure they are tight.

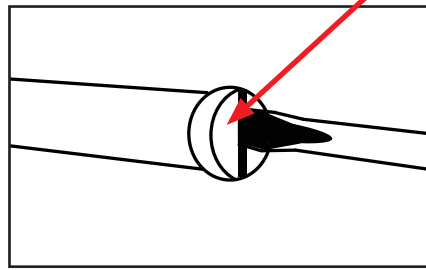

13. Spray or wipe out interior of the machine.

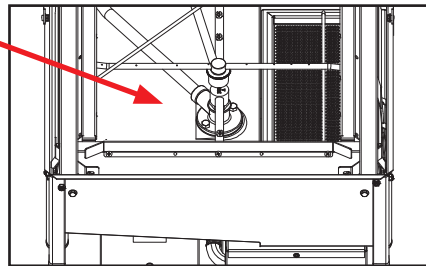

14. Replace wash and rinse arms.

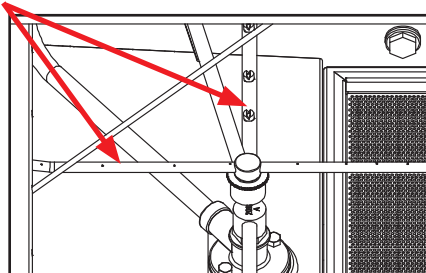

15. Ensure sump strainer and scrap screen are clean and securely in place.

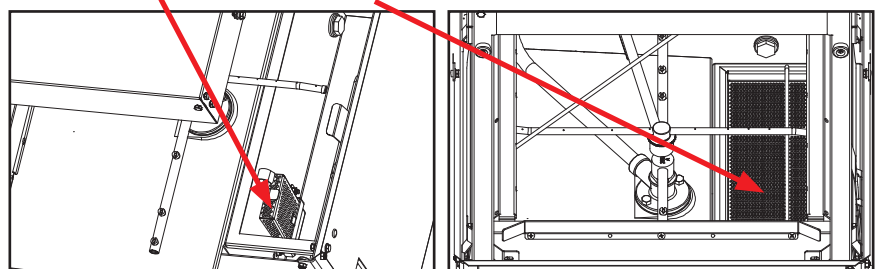

16. Use stainless steel polish to clean and protect outside of the machine.

VER COIL CLEANING

Coil on VER model must be inspected periodically. If the coil is greasy, dirty, or there is scale build-up, click [here](#) for cleaning instructions.



DETERGENT CONTROL

Detergent usage and water hardness are two factors that contribute greatly to how efficiently the machine will operate. Using detergent in proper amounts can become a source of substantial savings. A qualified water treatment specialist can determine what is needed for maximum efficiency from the detergent.

See Water Supply Connection section for more information on water treatment.

1. Hard water greatly affects performance of the machine, causing amount of detergent required for washing to increase. If the machine is installed in an area with hard water, the manufacturer recommends installation of water treatment equipment.
2. Deposited solids from hard water can cause spotting that will not be removed with a drying agent. Treated water will reduce this occurrence.
3. Treated water might not be suitable for use in other areas of operation and it might be necessary to install a water treatment system for the water going to the machine only. Discuss this option with a qualified water treatment specialist.
4. Machine operators should be properly trained on how much detergent is to be used per cycle. Meet with a water treatment specialist and detergent vendor to discuss a complete training program for operators.
5. The machine requires chemicals be provided for proper operation and sanitization and require installation of third-party chemical feeders to introduce these chemicals to the machine. Contact a chemical supplier with any questions.
6. Water temperature is an important factor in ensuring the machine functions properly. The machine's data plate details what the minimum temperatures must be for the incoming water supply, the wash tank, and the rinse tank. If minimum requirements are not met, there is a possibility that dishes will not be clean or sanitized.
7. Instruct machine operators to observe the required temperatures and to report when they fall below the minimum allowed. A loss of temperature can indicate a larger problem.



DELIMING To delime the machine, follow steps below. Tank capacities of the machine can be found on Operating Parameters page.

1. Remove rinse arms and place in sink with delimiting solution.
2. Disconnect or turn off chemical feeder pumps.
3. Add delimiting solution per chemical supplier's instructions.
4. Close door and turn the machine on in "MANUAL" mode.
5. Run the machine for length of time recommended by chemical supplier.
6. Flip mode switch to "AUTO" to shut the machine off.
7. Open door and step away for five minutes.
8. Inspect inside of the machine. If the machine is not delimed, run again.
9. When clean, drain and re-fill the machine.
10. Run two cycles in "AUTO" to remove residual delimiting solution.
11. Drain and re-fill the machine.
12. Flush rinse arms with water and replace.

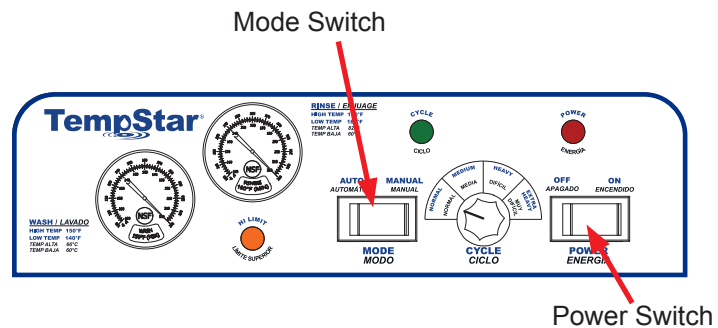

CAUTION! The machine is not recommended for use with deionized water or other aggressive fluids. Using deionized water or other aggressive fluids will result in corrosion and failure of components and will void the warranty.

PREVENTATIVE MAINTENANCE



The manufacturer highly recommends that any maintenance and repairs not specifically discussed in this manual be performed only by qualified service personnel.

WARNING! *Unqualified personnel performing maintenance on the machine may void the warranty, lead to larger problems, or cause harm to the operator.*



Following operating and cleaning instructions in this manual will result in the most efficient results from the machine. As a reminder, here are some steps to take to ensure the machine is being used the way it was designed to work:

CAUTION!
Do NOT beat strainers to remove debris!

1. Ensure water temperatures match those listed on machine data plate. A loss of temperature can indicate a larger problem.
2. Ensure all strainers are clean and securely in place before operating the machine. When cleaning out strainers, do NOT beat them on waste cans. Wipe out strainers with a rag and rinse with water if necessary. Use a toothpick to dislodge any stubborn debris.
3. Ensure all wash and rinse arms are secure in the machine before operating.
4. Ensure standpipe is in position before operating.
5. Remove as much soil from dishes by hand as possible before loading into racks.
6. Do not overfill racks.
7. Ensure glasses are placed upside-down in rack.
8. Ensure all chemicals being injected into the machine are at correct concentrations.
9. Clean the machine at end of every day/shift per Shutdown and Cleaning section.
10. Follow all safety procedures, whether listed in this manual or put forth by local, state, or national codes/regulations.

RESISTANCE-TO-TEMPERATURE VALUES

R (kΩ)	°F
11.58	69.8
10.37	75.2
9.30	80.6
7.78	89.6
3.05	140.0
2.54	150.8
2.18	159.8
1.58	179.6
1.45	185.0
1.33	190.4
1.16	199.4
0.96	212.0



WARNING! Inspection, testing, and repair of electrical equipment should only be performed by a qualified service technician. Many of the tests require that the unit have power to it and live electrical components be exposed. USE EXTREME CAUTION WHEN TESTING THE MACHINE.

PROBLEM	POSSIBLE CAUSE	REMEDY
Machine will not fill after the door is closed. Power "ON" light is illuminated.	<ol style="list-style-type: none"> 1. Faulty rinse solenoid valve. 2. Faulty door switch. 3. Fouled/faulty high-level probe. 	<ol style="list-style-type: none"> 1. Repair or replace valve as required. 2. Verify the wiring of the switch; if correct, replace the switch. 3. Clean probe if fouled. If clean and still not working, replace.
Machine will not fill after the door is closed. Power "ON" light is NOT illuminated.	<ol style="list-style-type: none"> 1. Service breaker tripped. 2. Machine not connected to power source. 3. Faulty power source. 	<ol style="list-style-type: none"> 1. Reset. If the breaker trips again, contact an electrician to verify the amp draw of the machine. 2. Verify the machine has been properly connected to the power source. 3. Verify the wiring of the switch; if correct, replace switch.
Machine will not run after the door is closed. Power "ON" light is illuminated and the machine is filling.	<ol style="list-style-type: none"> 1. Timer is faulty. 2. Wash motor faulty/damaged. 3. Wash motor contactor faulty. 	<ol style="list-style-type: none"> 1. Verify the timer is receiving power. If so, replace the timer assembly. 2. Verify the wash motor is getting power. If so, replace the motor. 3. Check for continuity; if contacts are open, replace the contactor.
Machine runs continuously in the wash cycle.	<ol style="list-style-type: none"> 1. Machine is in Delime mode. 2. Timer motor is faulty. 3. Cam timer jammed by obstruction. 	<ol style="list-style-type: none"> 1. Flip mode switch to "AUTO." 2. Verify the timer is rotating. If not, verify the motor is receiving power. If so, replace the motor and/or timer assembly. 3. Remove obstruction.
Wash or rinse heater does not work.	<ol style="list-style-type: none"> 1. Faulty heater element. 2. Faulty heater contactor. 3. Misadjusted/faulty thermostat(s). 	<ol style="list-style-type: none"> 1. Check element for continuity; if open, replace the heater. 2. Replace the contactor. 3. Verify operation and setting of thermostats, replace if necessary.
Machine fills slowly and/or the rinse is weak.	<ol style="list-style-type: none"> 1. Clogged or obstructed rinse arms. 2. Low incoming water pressure. 3. Y-strainer is clogged. 	<ol style="list-style-type: none"> 1. Remove and clean the rinse arms. 2. Adjust the water pressure regulator to ensure there is 10 ± 2 PSI flow. 3. Clean out the Y-strainer.
Rinse water not reaching required temperature.	<ol style="list-style-type: none"> 1. Faulty rinse heater. 2. Mis-adjusted/faulty thermostat(s). 3. Rinse thermometer is defective. 	<ol style="list-style-type: none"> 1. Check element for continuity; if open, replace heater. 2. Verify operation and setting of thermostats, replace if necessary. 3. Replace thermometer.



WARNING! Inspection, testing, and repair of electrical equipment should only be performed by a qualified service technician. Many of the tests require that the unit have power to it and live electrical components be exposed. USE EXTREME CAUTION WHEN TESTING THE MACHINE.

PROBLEM	POSSIBLE CAUSE	REMEDY
Machine doesn't drain when power switch is flipped to "OFF."	<ol style="list-style-type: none"> 1. Drain clogged. 2. Standpipe not removed before draining. 	<ol style="list-style-type: none"> 1. Remove obstruction. 2. Remove standpipe and run drain cycle again.
Incorrect water pressure displayed during Fill or Rinse modes.	<ol style="list-style-type: none"> 1. Water turned off. 	<ol style="list-style-type: none"> 1. Turn water on.
Wash water is not reaching required temperature.	<ol style="list-style-type: none"> 1. Faulty wash heater. 2. Misadjusted/faulty thermostat(s). 3. Wash thermometer is defective. 	<ol style="list-style-type: none"> 1. Check element for continuity; if open, replace the heater. 2. Verify operation and setting of thermostats, replace if necessary. 3. Replace thermometer.
Door will not close completely.	<ol style="list-style-type: none"> 1. Improper spring tension. 2. Obstruction in door channel. 3. Door panels are not square with frame. 	<ol style="list-style-type: none"> 1. Adjust spring tension as required by loosening (not removing) spring bolt nuts and adjusting the tension. Tighten nuts back when done. 2. Remove the obstruction. 3. Adjust the frame to accommodate the door panels.
Water leaks at the wash pump.	<ol style="list-style-type: none"> 1. Wash pump seal defective. 2. Petcock or pump drain (if equipped) not shut/tight. 3. Loose hoses (hose clamps) on the wash pump. 	<ol style="list-style-type: none"> 1. Replace the seal. 2. Close or tighten. 3. Tighten the hose clamps.
Will not rinse during autocycle.	<ol style="list-style-type: none"> 1. Defective rinse solenoid. 2. Faulty timer. 3. No water to the machine. 	<ol style="list-style-type: none"> 1. Repair or replace the rinse solenoid as required. 2. Replace timer. 3. Verify there is water at 10 ± 2 PSI connected to the machine.
Dishes are not coming clean.	<ol style="list-style-type: none"> 1. Machine temperatures are not up to the minimum requirements. 2. No detergent/too much detergent. 	<ol style="list-style-type: none"> 1. Verify incoming water, rinse water, and wash water match the required temperatures as listed on the machine data plate. 2. Adjust detergent concentration as required for the amount of water held by the machine.

NOTICE

Machines before 21D393474 have a different control box. Click [here](#) to open earlier manual.

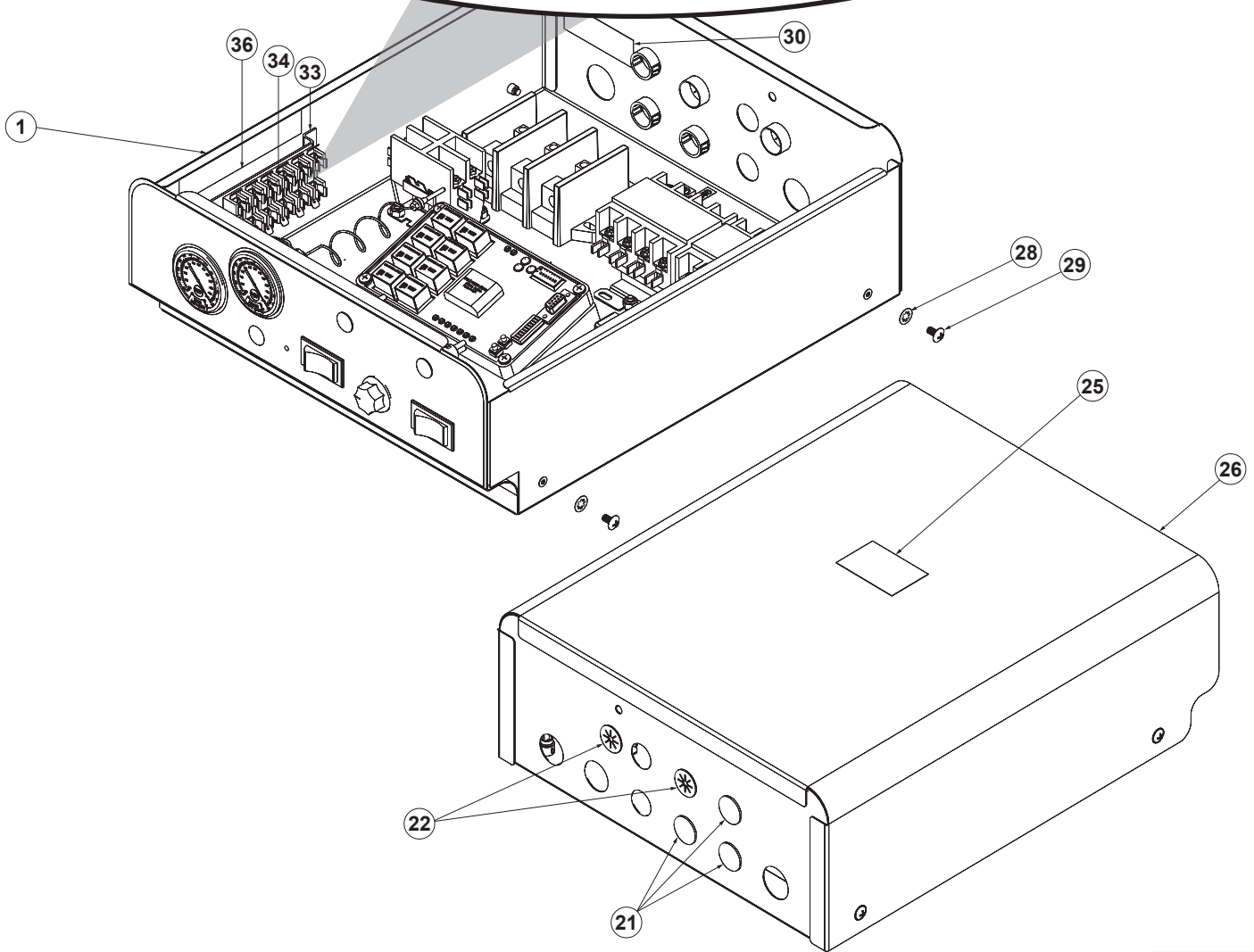
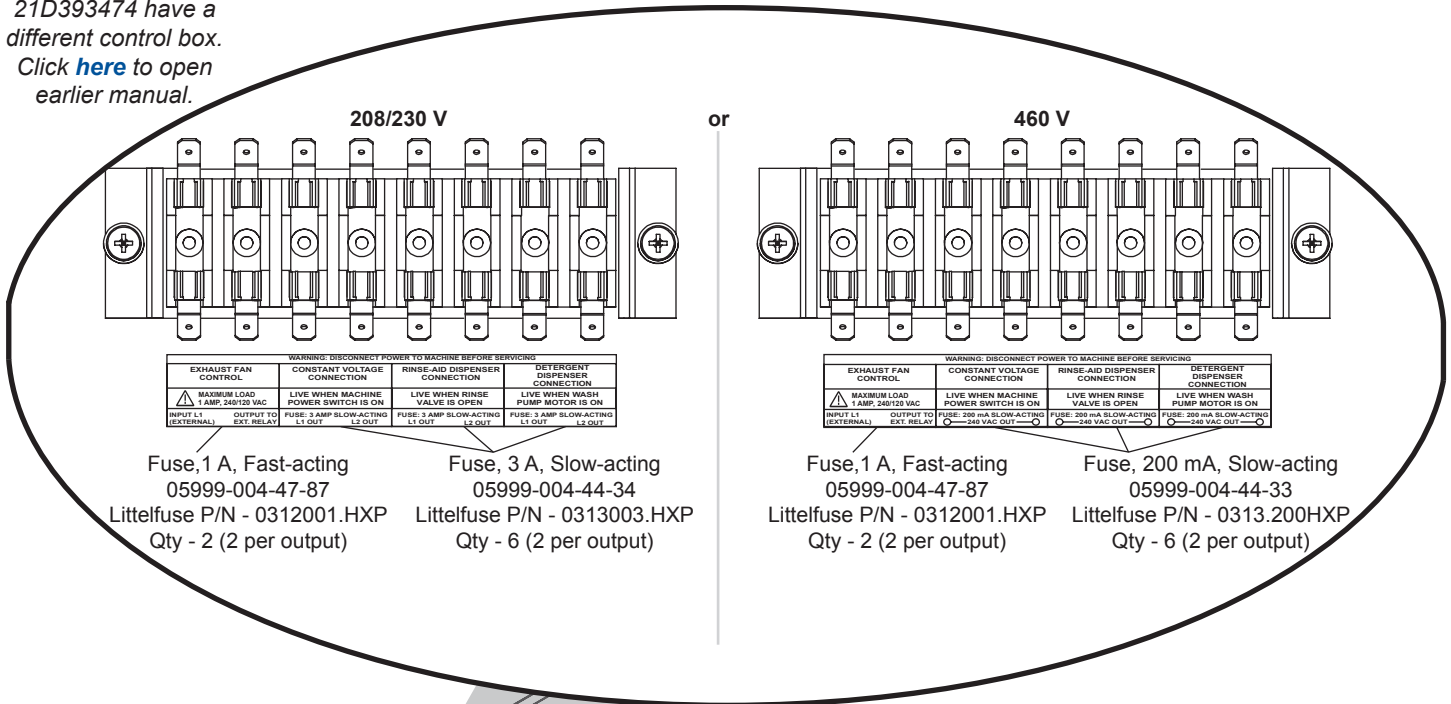

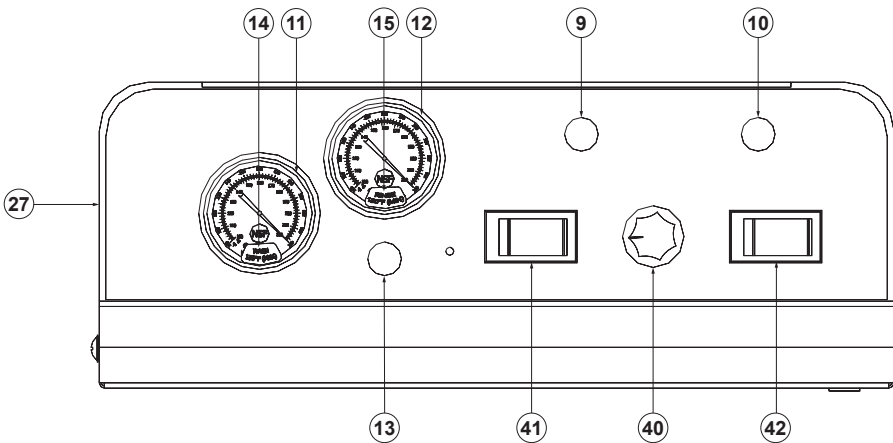
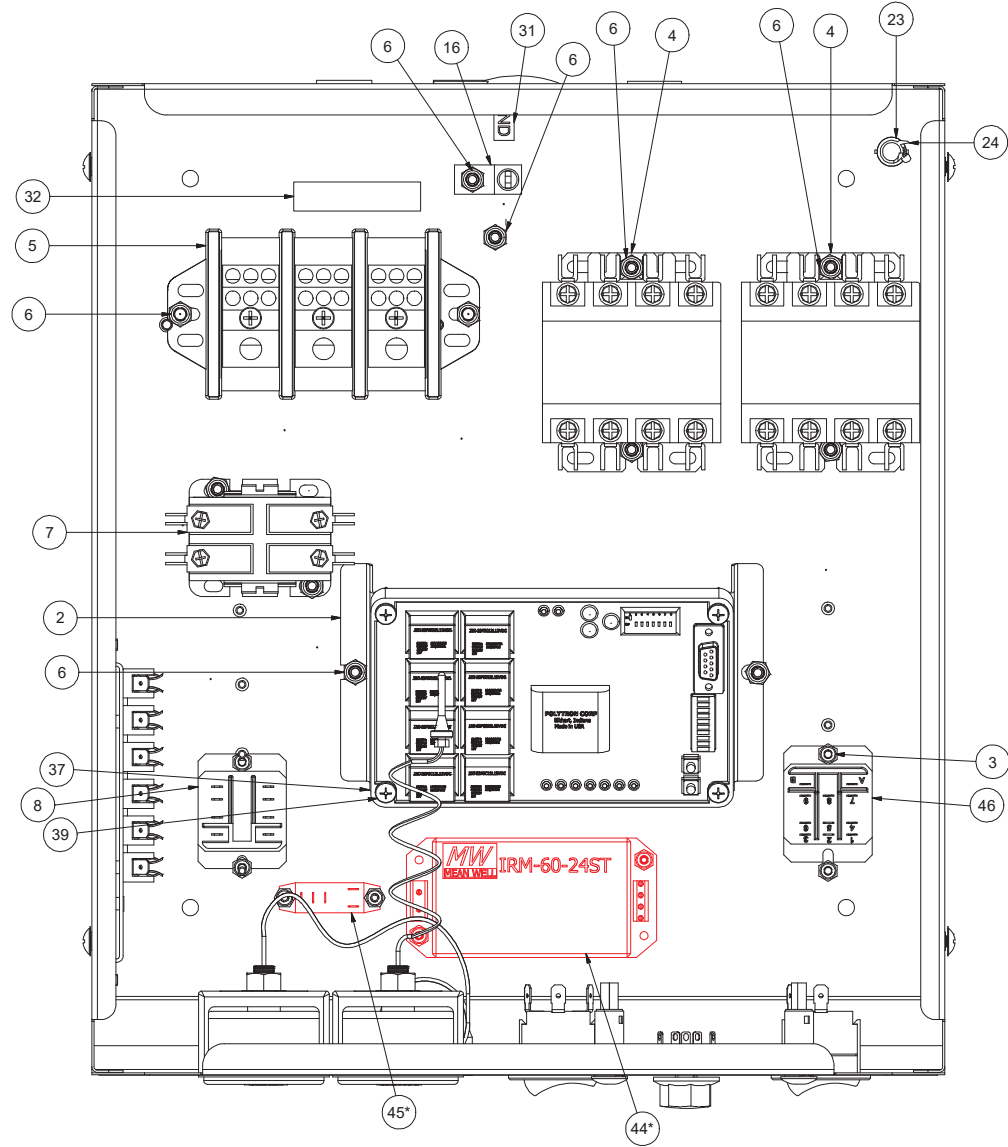

ITEM	QTY	DESCRIPTION	PART NUMBER
1	1	Control Box Weldment	05700-003-30-14
2	1	Timer Bracket	05700-003-02-08
3	2	Locknut, 6-32	05310-373-03-00
4	2	Contactora, 4-Pole	05945-004-43-74
5	1	Terminal Block	05940-011-48-27
6	17	Locknut, 10-24	05310-373-01-00
7	1	Contactora, Wash Motor	05945-002-74-20
8	1	Relay	05945-002-47-74
8a	1	Relay, (415 V, 3 PH, 5 Wire Only)	05945-111-89-75
9	1	Light, Green	05945-111-44-43
10	1	Light, Red	05945-111-44-45
11	1	Temperature Gauge, 96"	06685-004-31-46
12	1	Temperature Gauge, 48"	06685-004-31-47
13	1	Light, Yellow	05945-111-44-44
14	1	Decal, Wash 150 °F Min	09905-002-97-61
15	1	Decal, Rinse 180 °F Min	09905-002-97-62
16	1	Ground Lug	05940-200-76-00
17	1	Bracket, Liquid Level Control Board	05700-002-13-22
18	1	Liquid Level Control Board	06680-200-08-21
19	6	Tricnut, 6-32	05340-118-04-00
20	3	Screw, 6-32 x 5/8"	05305-011-39-85
21	3	Plug, 1/2"	05975-011-47-81
22	2	Grommet, 7/8" Split	05975-200-40-00
23	1	Bushing Snap	05975-210-05-00
24	1	Clamp, Hose 1/4" - 1/3"	05975-002-61-43
25	1	Decal, Warning-Disconnect Power	09905-004-08-16
26	1	Cover, Top Mount Control Box	05700-002-23-03
27	1	Decal, Control Box	09905-003-97-36
28	4	Lockwasher, Int. Tooth #10	05311-273-03-00
29	4	Screw, 10-32 x 3/8" Phillips Truss Head	05305-173-12-00
30	1	Decal, Copper Conductors	09905-011-47-35

ITEM	QTY	DESCRIPTION	PART NUMBER
31	1	Decal, Ground	09905-011-86-86
32	1	Decal, L1, L2	09905-002-78-67
33	1	Bracket, Fuse Strip	05700-002-42-03
34	1	Fuse Holder, 6-pole	05920-002-42-13
35	2	Screw, 6-32 x 3/8" with Tooth Washer	05305-002-25-91
36	1	Decal, Dispenser Connection	09905-003-34-09
	1	Decal, Dispenser Connection (460 V Machine Only)	09905-004-43-81
37	1	Kit, Universal Timer with Bracket	06401-003-80-83
		Universal Timer, Fused	05945-003-75-23
38	4	Locknut, 10-32	05310-373-02-00
39	4	Screw 10-32 x 1"	05305-002-19-42
40	1	Switch, Rotary Selector	05930-003-97-61
41	1	Switch, Operation	05930-301-53-00
42	1	Switch, Power	05930-011-49-55
43	1	Dome Plug	05975-002-29-94
44*	1	Power Supply, In 100-240 V DC, 1.8 A, Out 24 V, 2.5 A*	05950-004-81-79*
45*	1	Relay, 10 A, 220 V*	05945-004-84-93*
46	1	Relay, 240 V	05945-002-47-74
47	1	Transformer, 460 V Machine Only (Not Shown)	05950-111-65-93
47a	1	Fuse Holder, Single, 460 V Machine Only (Not Shown)	05920-011-72-89
47b	1	Fuse, 1 A, Bussman P/N FNQ-R-1, 460 V Machine Only (Not Shown)	05920-002-67-23
48	1	Pump Contactor, 460 V Machine Only (Not Shown)	05945-002-65-00
49	1	Overload, 4NK0AKY 1.7-2.6, 460 V Machine Only (Not Shown)	05945-002-65-02

*Power supply and relay used only on machines with door interlock and VER machines with DC fans.

NOTICE

Machines before
21D393474 have a
different control box.
Click [here](#) to open
earlier manual.

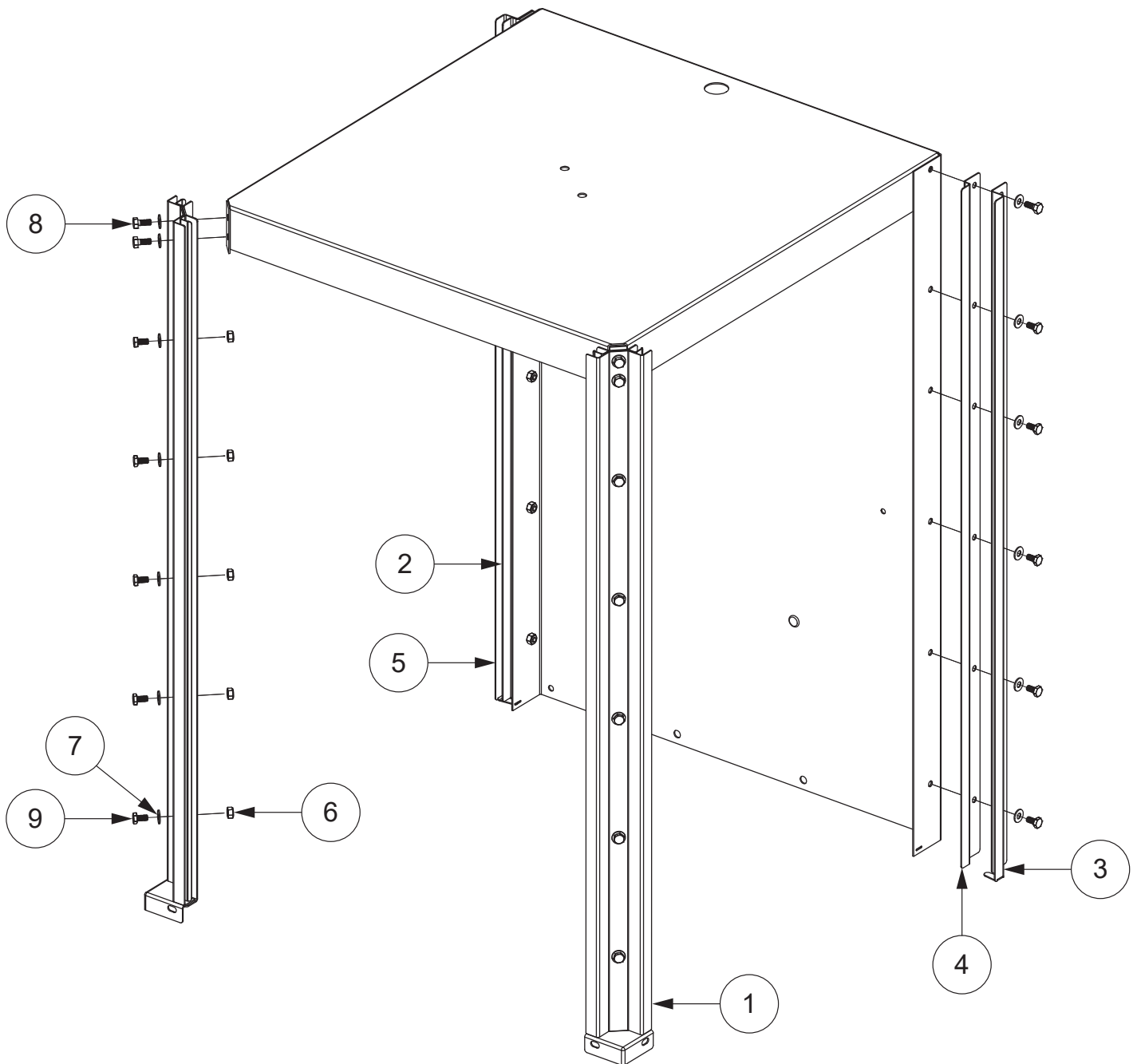

ITEM	QTY	DESCRIPTION	PART NUMBER
1	2	Hood Support Assembly	05700-004-13-45
2	1	Left Back Inner Door Guide	05700-031-76-34
3	1	Right Back Outer Door Guide	05700-031-76-32
4	1	Right Back Inner Door Guide	05700-031-76-35
5	1	Left Back Outer Door Guide	05700-031-76-33
6	34	Locknut, 1/4-20 Hex with Nylon Insert	05310-374-01-00
7	26	Washer, 1/4-20	05311-174-01-00
8	6	Screw, 1/4-20 x 5/8" Hex	05305-274-24-00
9	20	Bolt, 1/4-20 x 1/2"	05305-274-02-00

DOOR SWITCH AND BRACKET

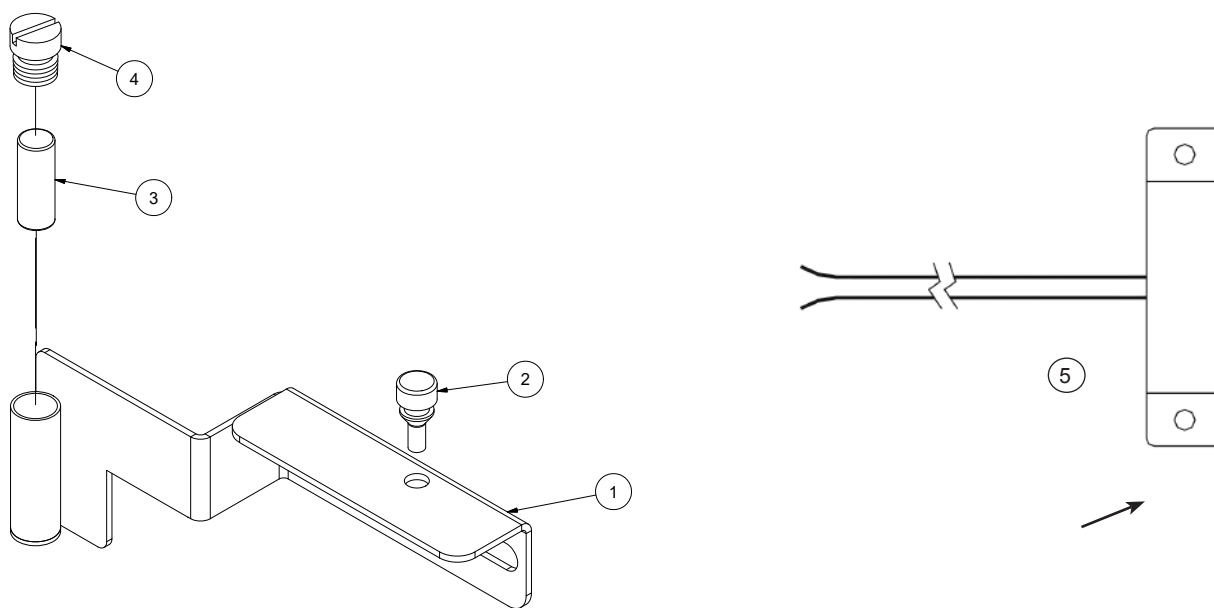

ITEM	QTY	DESCRIPTION	PART NUMBER
1	1	Complete Assembly, Bracket, Magnet Mounting Bracket, Magnet Mounting	05700-004-48-16 05700-004-47-83
2	1	Bumper, Door	05700-004-14-25
3	1	Magnet, N50	05930-003-31-63
4	1	End-cap	05700-011-60-92
5	1	Magnetic Door Switch	05930-003-05-84

NOTICE

Machines before 18C355287 have a different door and arm assembly. Click [here](#) to open earlier manual.

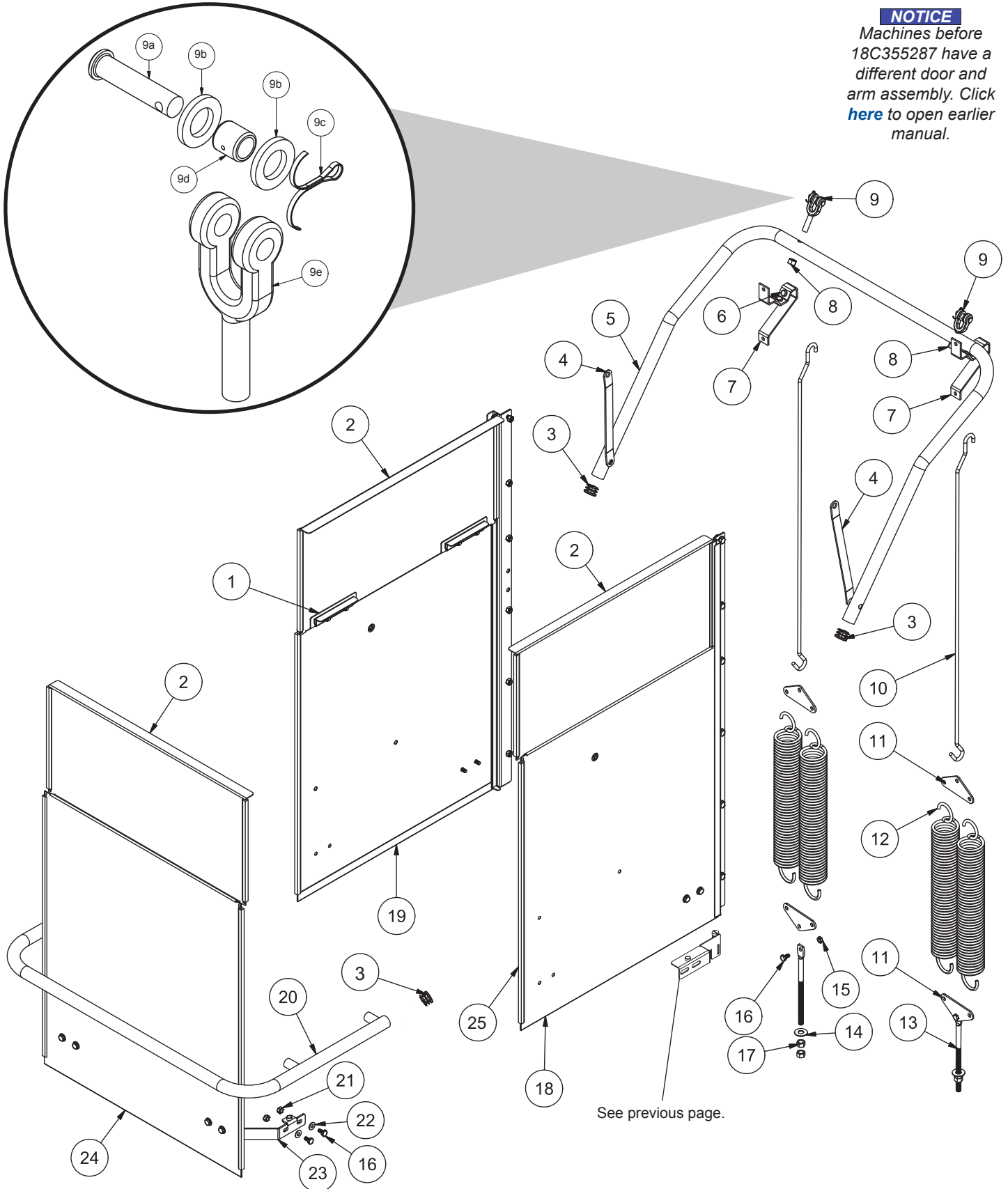

ITEM	QTY	DESCRIPTION	PART NUMBER
1	6	Door Stop Kit	06401-003-08-69
2	3	Upper Door, Complete Assembly	05700-002-01-30
3	4	Plug, Cantilever	05340-011-35-00
4	2	Connecting Link	05700-021-92-45
5	1	Cantilever Arm, Complete Assembly (items 3, 5, 8, 9) Cantilever Arm, Arm Only	05700-004-51-87 05700-004-51-40
6	6	Wear Button	05700-011-88-01
7	2	Bracket, Cantilever Arm Support	05700-031-88-00
8	2	Nut, 3/8-16 Hex Locking	05310-256-04-00
9	2	Yoke, Complete Assembly	05700-000-75-77
9a	1	Clevis Pin, 5/16" x 1 3/8"	05315-700-01-00
9b	2	Nylon Washer	05311-369-03-00
9c	1	Cotter Pin	05315-207-01-00
9d	1	Bushing	03120-100-03-00
9e	1	Yoke	05700-000-75-78
10	2	Rod, Spring Connecting	05700-002-00-91
11	4	Plate, Spring Multiplier	05700-002-00-88
12	4	Spring, Cantilever Door	05340-111-35-22
13	2	Bolt, Cantilever Hanger Eye 3/8-16	05306-956-05-00
14	2	Washer, Impeller	05311-176-02-00
15	4	Locknut, 1/4-20 Low-profile with Nylon Insert	05310-374-02-00
16	4	Bolt, 1/4-20 x 1/2" Hex	05305-274-02-00
17	4	Nut, 3/8-16 Hex	05310-276-01-00
18	1	Right Door, Complete Assembly	05700-004-51-86
19	1	Left Door, Complete Assembly	05700-004-51-85
20	1	Handle, Front Door	05700-004-51-39
21	4	Locknut, 1/4-20 with Nylon Insert	05310-374-01-00
22	4	Washer, 1/4-20	05311-174-01-00
23	2	Bracket, Door Connecting Bumper, Door Connecting (Not Shown)	05700-004-14-24 05700-004-14-25
24	1	Front Door, Complete Assembly	05700-004-14-21
25	6	Door Glide	05700-002-23-64

NOTICE

Machines before
18C355287 have a
different door and
arm assembly. Click
[here](#) to open earlier
manual.

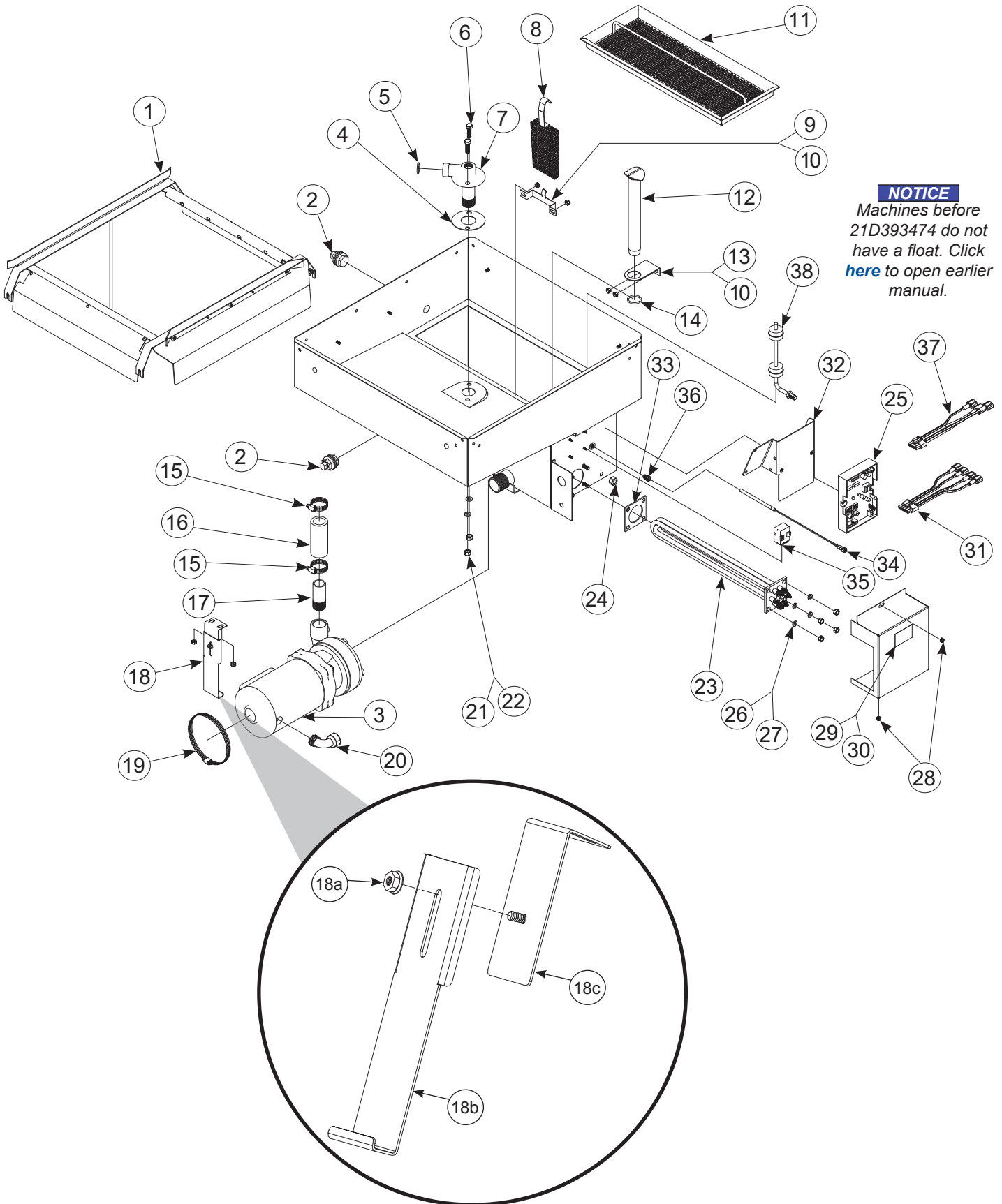

NOTICE
 Machines before 21D393474 do not have a float. Click [here](#) to open earlier manual.

ITEM	QTY	DESCRIPTION	PART NUMBER
1	1	Track Assembly	05700-002-01-00
2	2	Bulk Head Plug	04730-609-05-00
3	1	Wash Motor	See Motors page.
4	1	Gasket	05700-111-35-03
5	1	O-ring	05330-111-35-15
6	4	Bolt, Hex 3/8-16 x 1 1/4" Long	05305-276-10-00
7	1	Lower Wash Manifold Weldment	05700-031-46-00
8	1	Sump Strainer	05700-001-22-23
9	1	Bracket, Sump Strainer	05700-001-22-24
10	8	Locknut, 1/4-20 with Nylon Insert	05310-374-02-00
11	1	Scrap Screen	05700-003-07-76
12	1	Standpipe	05700-001-25-69
12a	1	Support, Ball Stop Lift (Not Shown)	05700-002-91-55
12b	1	Ball Stop Lift (Not Shown)	05700-002-91-54
13	1	Overflow Support Bracket	05700-001-27-55
13a	1	Shim, Overflow Support (Not Shown)	05700-002-96-48
14	1	O-ring	05330-400-05-00
15	2	Clamp, Hose 1 5/16" to 2 1/4"	04730-719-01-37
16	1	Discharge Hose	05700-011-88-24
17	1	Nipple	05700-021-34-84
18	1	Pump Support Bracket Assembly	05700-002-00-46
18a	1	Nut, 1/4-20 Hex Nut	05310-011-66-49
18b	1	Pump Support Adjustable Bracket	05700-002-20-41
18c	1	Bracket, Pump Support	05700-002-68-31
19	1	Clamp, Hose 5 5/8" to 6"	04730-011-34-90
20	1	Connector, 1/2"	05975-111-01-00
21	4	Nut, 3/8-16 Hex	05310-276-01-00
22	4	Lockwasher 3/8"	05311-276-01-00
23	1	Heater	See Heaters page.
24	1	Nut, Float Switch	05310-011-72-58
25	1	Thermostat, Electric Dual	06685-004-17-27

ITEM	QTY	DESCRIPTION	PART NUMBER
26	4	Lockwasher, 5/16", Split	05311-275-01-00
27	4	Nut, Hex, 5/16-18	05310-275-01-00
28	4	Locknut, 10-24 with Nylon Insert	05310-373-01-00
29	1	Cover, Wash Heater	05700-031-47-57
30	1	Decal, Warning-Disconnect Power	09905-004-08-16
31	1	Harness, 5-Connector	05700-004-23-78
32	1	Thermostat Mounting Bracket	05700-004-22-17
33	1	Wash Heater Gasket	05330-011-47-79
34	1	Probe, Thermistor 4"	06685-004-17-26
35	1	Thermostat, High Limit	05930-004-33-12
36	1	Fitting, 1/4" Imperial Brass	05310-924-02-05
37	1	Harness, 4-Connector	05700-004-23-79
38	1	Float Switch	06680-121-70-71

NOTICE

*Machines before
21D393474 do not
have a float. Click
[here](#) to open earlier
manual.*

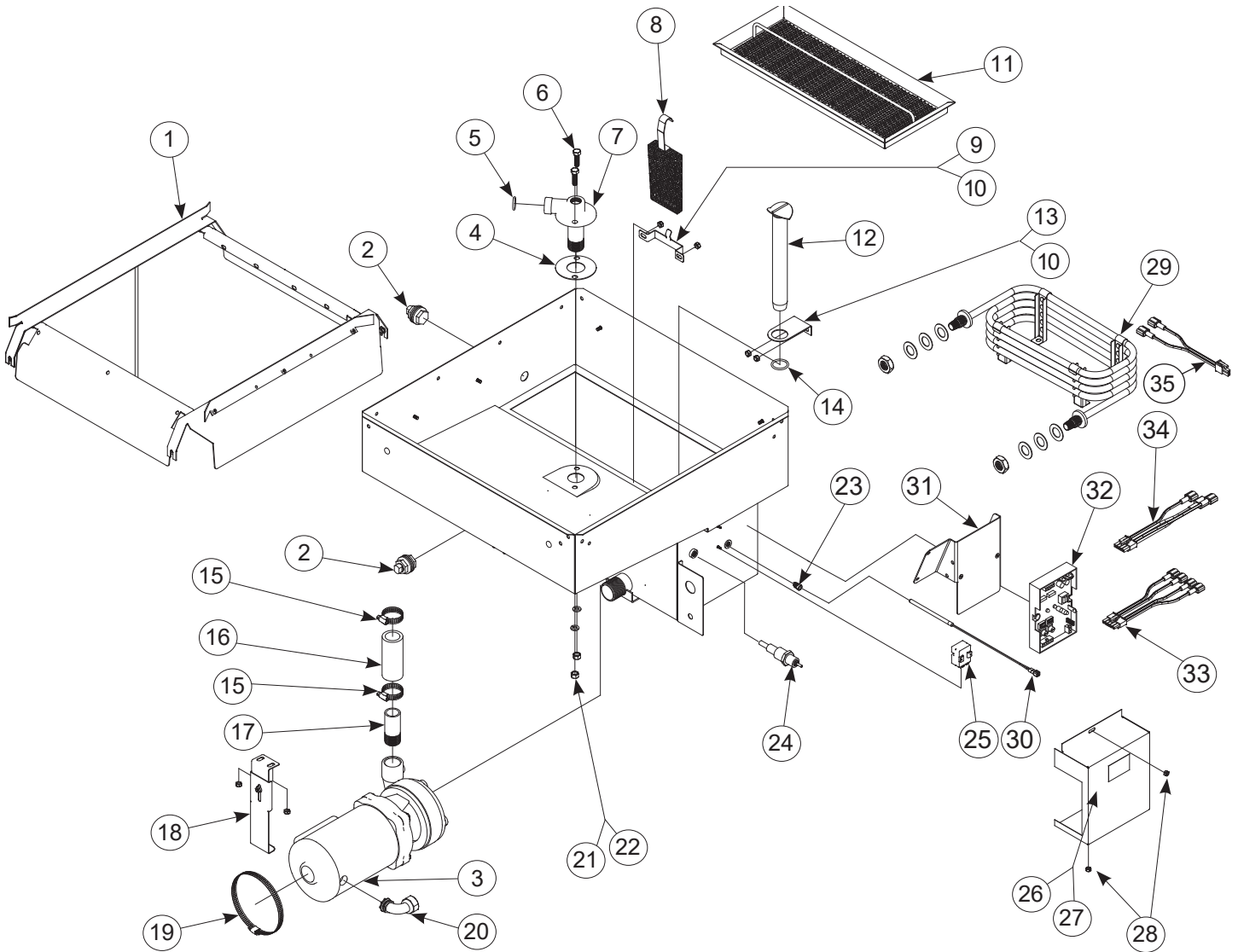

ITEM	QTY	DESCRIPTION	PART NUMBER
1	1	Track Assembly	05700-002-01-00
2	2	Bulk Head Plug	04730-609-05-00
3	1	Wash Motor	See Motors page.

ITEM	QTY	DESCRIPTION	PART NUMBER
4	1	Gasket	05700-111-35-03
5	1	O-ring	05330-111-35-15
6	4	Bolt, Hex 3/8-16 x 1 1/4"	05305-276-10-00
7	1	Lower Wash Manifold Weldment	05700-031-46-00
8	1	Sump Strainer	05700-002-16-13
9	1	Bracket, Sump Strainer	05700-002-18-28
10	8	Locknut, 1/4-20 with Nylon Insert	05310-374-02-00
11	1	Strainer Weldment	05700-003-07-76
12	1	Wash Overflow Weldment	05700-001-25-69
12a	1	Support, Ball Stop Lift (Not Shown)	05700-002-91-55
12b	1	Ball Stop Lift (Not Shown)	05700-003-07-50
13	1	Overflow Support Bracket	05700-001-27-55
13a	1	Shim, Overflow Support (Not Shown)	05700-002-96-48
14	1	O-ring	05330-400-05-00
15	2	Clamp, Hose 1 5/16" to 2 1/4"	04730-719-18-00
16	1	Discharge Hose	05700-011-88-24
17	1	Nipple	05700-021-34-84
18	1	Pump Support Bracket Assembly	See Item #18 on Tub pages.
19	1	Clamp, Hose 5 5/8" to 6"	04730-011-34-90
20	1	Connector, 1/2"	05975-111-01-00
21	4	Nut, 3/8-16 Hex	05310-276-01-00
22	4	Lockwasher, 3/8"	05311-276-01-00
23	1	Fitting, 1/4" Imperial Brass	05310-924-02-05
24	1	Probe, High Water	06680-200-02-68
25	1	Thermostat, High Limit	05930-004-33-12
26	1	Cover, Wash Heater	05700-031-47-57
27	1	Decal, Warning-Disconnect Power	09905-004-08-16
28	2	Locknut, 10-24 with Nylon Insert	05310-373-01-00
29	1	Steam Coil	05700-031-41-37
30	1	Probe, Thermistor 4"	06685-004-17-26
31	1	Thermostat Mounting Bracket	05700-004-22-17
32	1	Thermostat, Elan Electric Dual	06685-004-17-27
33	1	Harness, 5-Connector	05700-004-23-78
34	1	Harness, 4-Connector	05700-004-23-79
35	1	Harness, 2-Connector	05700-004-23-80

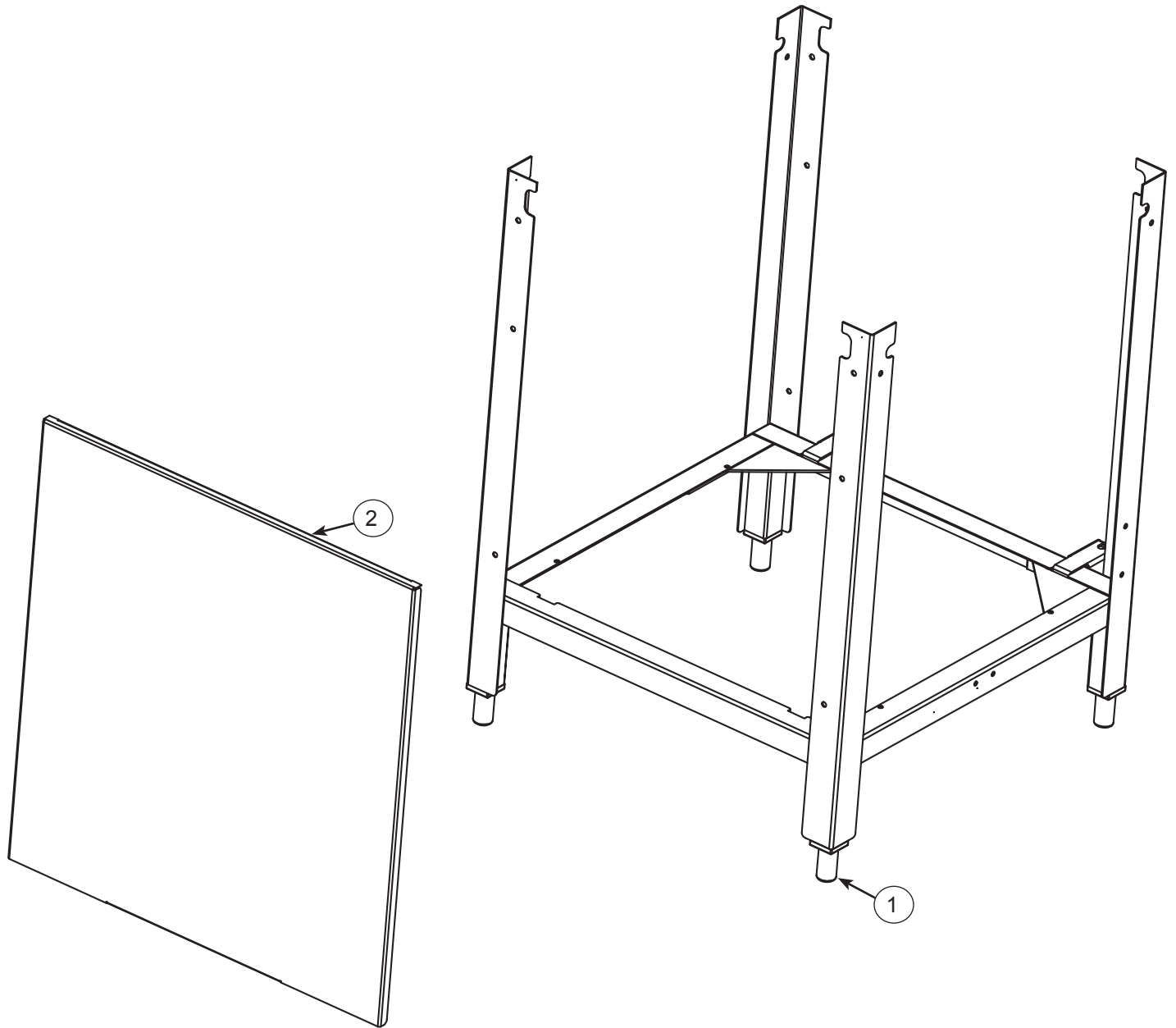

ITEM	QTY	DESCRIPTION	PART NUMBER
1	4	Adjustable Foot, 1 1/2" Adjustable Foot, 3" Adjustable Foot, Flanged	05340-108-02-06 05340-002-14-55 05340-002-01-15
2	1	Front Dress Panel	05700-002-01-42

Complete Assemblies

208-230 V, 14 kW 70° Rise - 05700-004-43-33

208-230 V, 12 kW 40° Rise - 05700-004-52-19

460 V, 14 kW 70° Rise - 05700-004-53-22

460 V, 12 kW 40° Rise - 05700-004-53-21

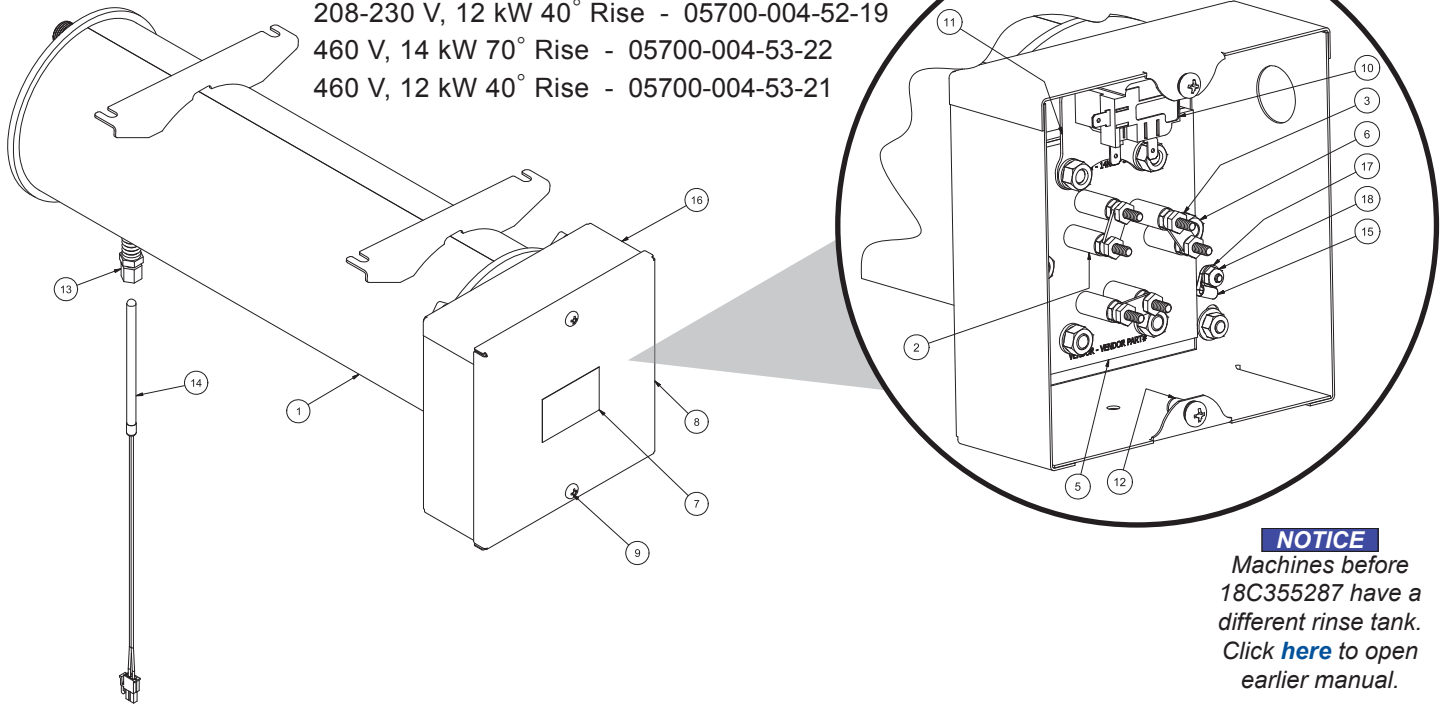
**NOTICE**

Machines before
18C355287 have a
different rinse tank.
Click [here](#) to open
earlier manual.

ITEM	QTY	DESCRIPTION	PART NUMBER
1	1	Tank, Rinse	05700-004-50-86
2	1	Heater, Rinse	See Heaters page.
3	6	Lockwasher, Split 5/16"	05311-275-01-00
4	1	Fitting, 1/4", Brass Nut/Sleeve	05310-924-02-05
5	1	Gasket, Rinse Heater	05330-200-02-70
6	6	Nut, Hex 5/16-18	05310-275-01-00
7	1	Decal, Warning-Disconnect Power	09905-100-75-93
8	1	Cover, Heater	05700-004-51-34
9	2	Screw	05305-004-27-82
10	1	Thermostat, High-limit	05930-004-33-12
11	1	Bracket, High-limit Thermostat	05700-004-36-84
12	2	Nut, 1/4-20	05310-004-23-96
13	1	Union, 1/4"	05700-001-16-52
14	1	Thermistor Probe	06685-004-34-58
15	1	Clamp, Wire 1/8", P-clip	05975-601-10-15
16	1	Cover Door, New Rinse Tank	05700-004-52-21
17	1	Washer, Flat	05311-173-02-00
18	1	Locknut, Hex 8-32	05310-272-02-00

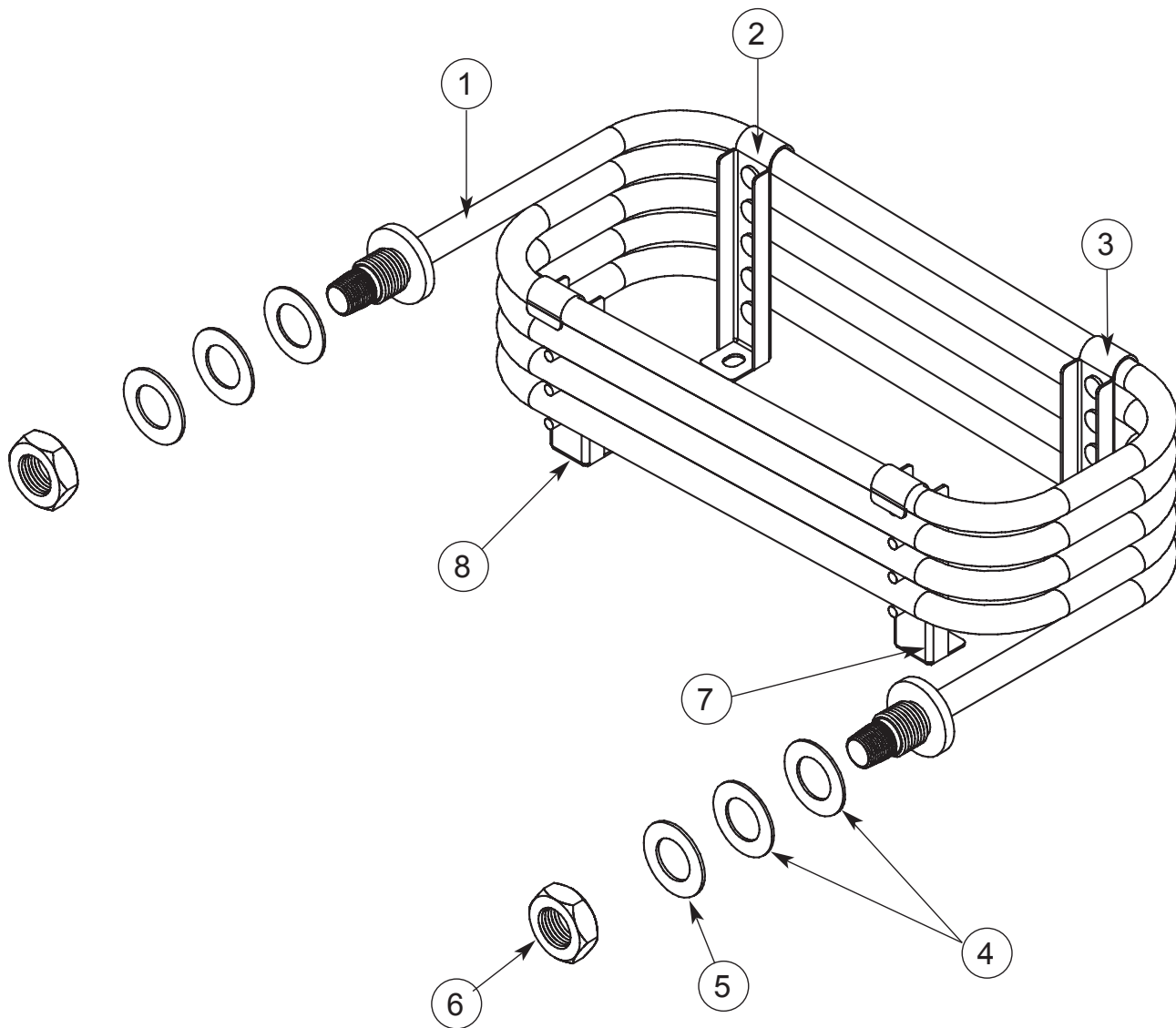

ITEM	QTY	DESCRIPTION	PART NUMBER
	1	Steam Coil, Complete Assembly	05700-002-08-62
1	1	Steam Coil	05700-021-41-38
2	1	Stand C, Steam Coil Support	05700-002-08-52
3	1	Stand D, Steam Coil Support	05700-002-08-53
4	1	Gasket, Steam Coil	05700-001-17-86
5	2	Washer, Steam Coil	05700-001-17-87
6	2	Adapter, Steam Coil Nut	05310-011-17-85
7	1	Stand A, Steam Coil Support	05700-002-08-50
8	1	Stand B, Steam Coil Support	05700-002-08-51

Complete Assemblies
(See next page for parts.)

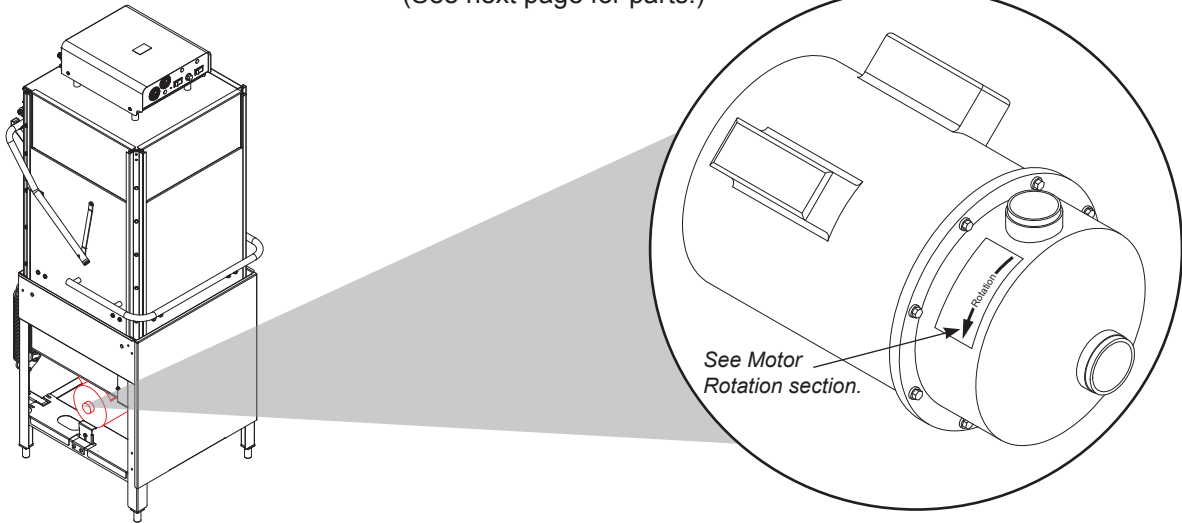

The models covered in this manual come supplied with various wash motor assemblies (a wash motor assembly includes the wash motor and the pump end), depending on the characteristics of the machine. To ensure you order the correct wash motor assembly for the model you are servicing, please refer to the following table:

MODEL	VOLTS	Hz	PHASE	WASH MOTOR ASSEMBLY
HH-E Series & HH S	208	60	1	06105-002-01-29
HH-E Series & HH S	230	60	1	06105-002-01-29
HH-E Series & HH S	208	60	3	06105-002-01-29
HH-E Series & HH S	230	60	3	06105-002-01-29
HH-E Series	460	60	3	06105-002-09-30

NOTICE When servicing a wash motor, it is important to refer to the wiring schematic found on the motor to ensure the motor is wired correctly. Different manufacturers of motors might not use the same wire color codes and your new motor might not connect using the same wires. Always refer to the wiring diagrams on the motor you are installing. If the motor you are installing has had the schematic removed, contact the manufacturer immediately for technical support.

Complete Motor Mount Assembly
05700-004-13-10

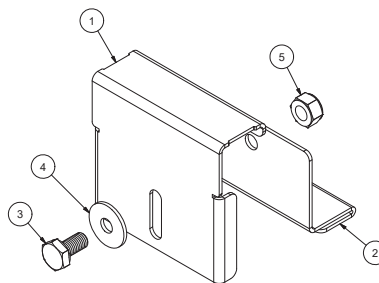

ITEM	QTY	DESCRIPTION	PART NUMBER
1	1	Bracket, Motor Mount Outer	05700-004-13-08
2	1	Bracket, Motor Mount Inner	05700-004-13-07
3	1	Bolt, 1/4-20 x 1/2"	05305-274-02-00
4	1	Washer, 1/4" ID x 3/4" OD	05311-011-76-30
5	1	Locknut, 1/4-20 Hex with Nylon Insert	05310-374-01-00

Parts

(See previous page for complete assemblies.)

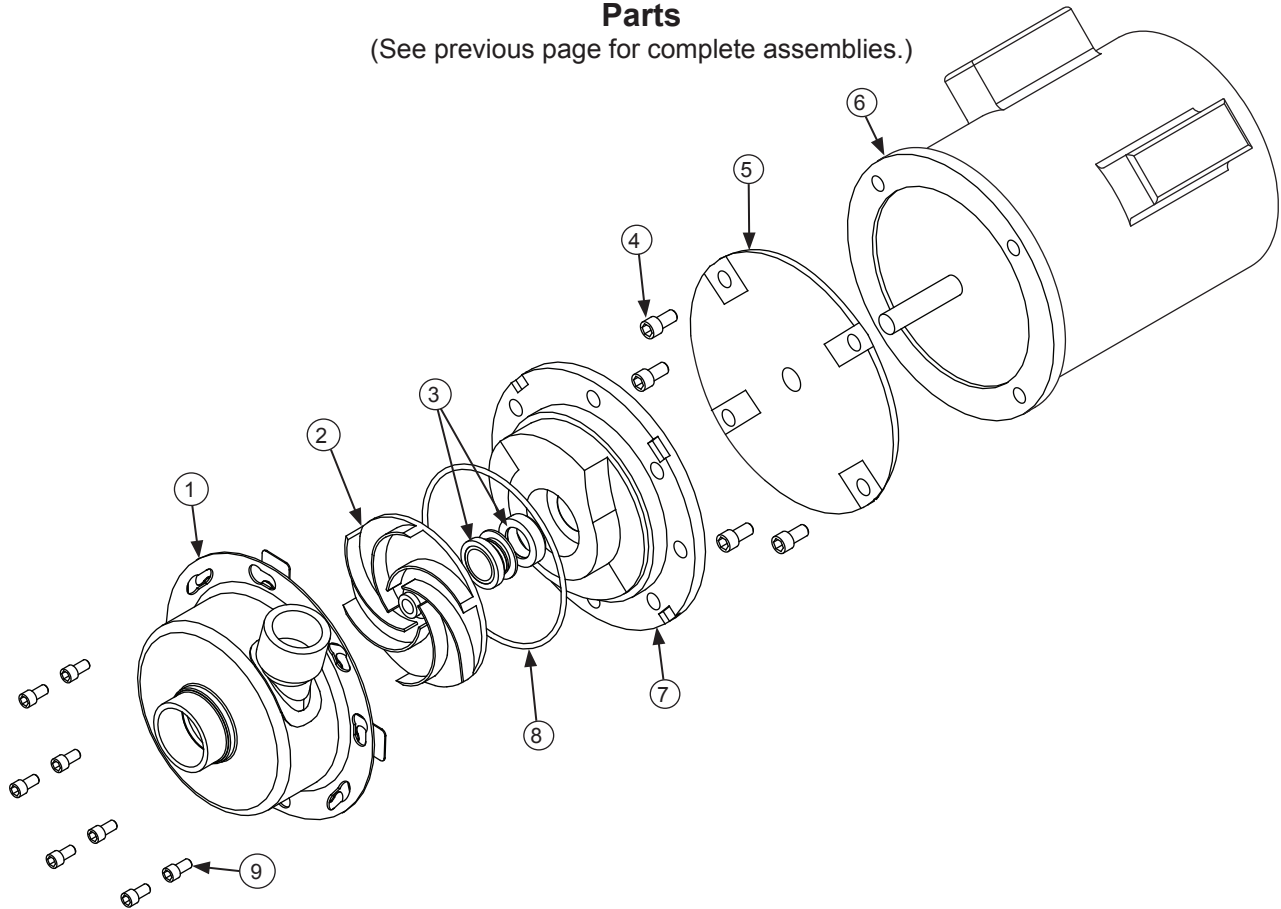

ITEM	QTY	DESCRIPTION	PART NUMBER
1	1	Pump Casing 208/230 V	05700-002-82-57
	1	Pump Casing 460 V	05700-002-06-20
2	1	Impeller Assembly, 208/230 V	05700-002-82-50
	1	Impeller Assembly, 460 V	05700-002-06-19
3	1	Mechanical Seal, 208/230 V	05330-002-34-22
	1	Mechanical Seal, 460 V	05330-002-87-16
4	4	Motor Bolt	05700-002-82-55
5	1	Motor Adapter	05330-002-82-53
6	1	Motor Only	06105-002-82-60
7	1	Seal Plate, 208/230 V	05700-002-82-52
	1	Seal Plate, 460 V	05700-002-06-22
8	1	Case O-ring, 208/230 V	05330-002-34-23
	1	Case O-ring, 460 V	05330-002-87-02
9	8	Case Screws	05305-002-81-88
10	1	Shim Kit, 208/230 V (Not Shown)	05700-002-82-58
	1	Shaft Adapter, 460 V (Not Shown)	05700-011-95-19

TempStar HH-E

Volts	Hz	Phase	Wash Heater	Rinse Heater (12 kW)	Rinse Heater (14 kW)
208	50	1	04540-121-47-39	04540-121-47-40	04540-121-63-38
208	50	3	04540-121-47-39	04540-121-47-40	04540-121-63-38
208	60	1	04540-121-47-39	04540-121-47-40	04540-121-63-38
208	60	3	04540-121-47-39	04540-121-47-40	04540-121-63-38
230	50	1	04540-121-47-39	04540-121-47-40	04540-121-63-38
230	50	3	04540-121-47-39	04540-121-47-40	04540-121-63-38
230	60	1	04540-121-47-39	04540-121-47-40	04540-121-63-38
230	60	3	04540-121-47-39	04540-121-47-40	04540-121-63-38
380	50	3	04540-002-44-31	04540-002-44-32	04540-121-63-38
415	50	3	04540-002-43-09	04540-002-43-10	N/A
440	50	3	04540-121-65-99	04540-100-01-15	04540-121-63-39
460	60	3	04540-121-65-99	04540-100-01-15	04540-121-63-39

TempStar HH-E-VER

Volts	Hz	Phase	Wash Heater	Rinse Heater (14 kW)
208	50	1	04540-121-47-39	04540-121-63-38
208	50	3	04540-121-47-39	04540-121-63-38
208	60	1	04540-121-47-39	04540-121-63-38
208	60	3	04540-121-47-39	04540-121-63-38
230	50	1	04540-121-47-39	04540-121-63-38
230	50	3	04540-121-47-39	04540-121-63-38
230	60	1	04540-121-47-39	04540-121-63-38
230	60	3	04540-121-47-39	04540-121-63-38
380	50	3	04540-002-44-31	04540-121-63-38
415	50	3	04540-002-43-09	N/A
440	50	3	04540-121-65-99	04540-121-63-39
460	60	3	04540-121-65-99	04540-121-63-39

TempStar HH-E NB

Volts	Hz	Phase	Wash Heater
208	50	1	04540-121-47-39
208	50	3	04540-121-47-39
208	60	1	04540-121-47-39
208	60	3	04540-121-47-39
230	50	1	04540-121-47-39
230	50	3	04540-121-47-39
230	60	1	04540-121-47-39
230	60	3	04540-121-47-39
380	50	3	04540-002-44-31
415	50	3	04540-002-43-09
440	50	3	04540-121-65-99
460	60	3	04540-121-65-99

Heater Phase Conversion Kit
06401-004-00-22

NOTICE Before ordering plumbing parts, see the note on the next page.

Top View

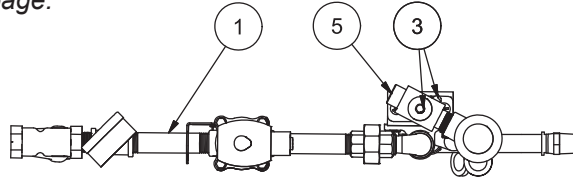

Back View

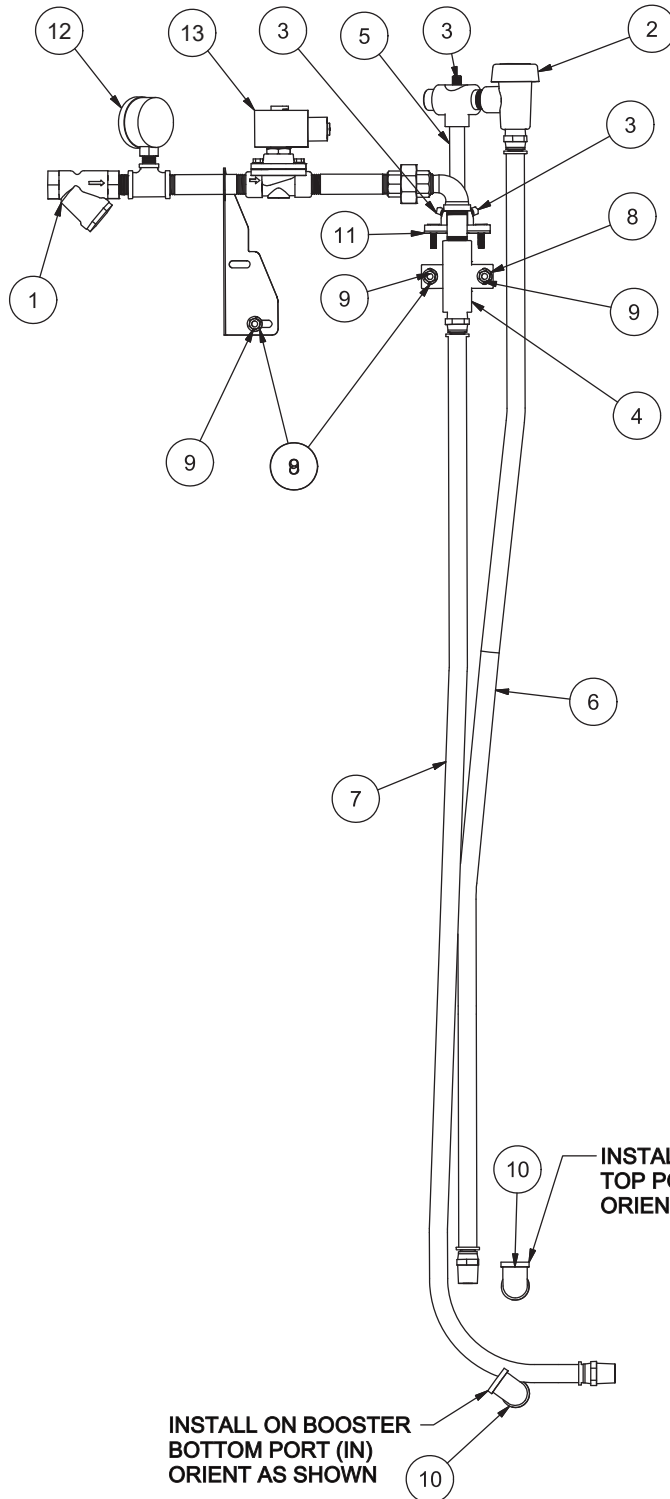

ITEM	QTY	DESCRIPTION	PART NUMBER
	1	Plumbing, HH-E, Complete Assembly	05700-004-52-85
1	1	Plumbing, Inlet HH-E	05700-004-47-98
2	1	Vacuum Breaker, 1/2" Brass	04820-003-06-13
3	3	Plug, 1/8" Brass	04730-209-07-37
4	1	Casting, 1/2" Flanged Coupling	05700-004-47-97
5	1	Rinse Injector	05700-002-56-75
	1	Gasket, Rinse Injector (Not Shown)	05330-111-42-81
6	1	Hose, 1/2" x 47" Red	05700-004-48-24
7	1	Hose, 1/2" x 48" Blue	05700-004-48-23
8	3	Washer, 1/4-20 Hex with Nylon Insert	05311-174-01-00
9	3	Locknut, 1/4-20 Hex with Nylon Insert	05310-374-01-00
10	2	Elbow, 1/2" 90-degree Brass	04730-011-42-96
11	1	Gasket, Rinse Manifold	05330-003-75-91
12	1	Pressure Gauge, 0-100 PSI	06685-111-88-34
13	1	Valve, 1/2" x 1/2" Brass	04810-003-71-56

NOTICE

When servicing plumbing components, take care not to damage the threads of each individual item. Damaged threads can cause leaks and loss of pressure, which could adversely affect the performance of the machine. It is strongly recommended that teflon thread tape, used in conservative amounts, be applied to threads when joining components together. It is not advised to use thread-sealing compounds, sometimes referred to as "pipe dope." Compounds can be ejected from the threads during the tightening process and become lodged in key components, rendering them useless.

NOTICE

Machines before 18C355287 have different plumbing. Click [here](#) to open earlier manual.

NOTICE Before ordering plumbing parts, see the note on the next page.

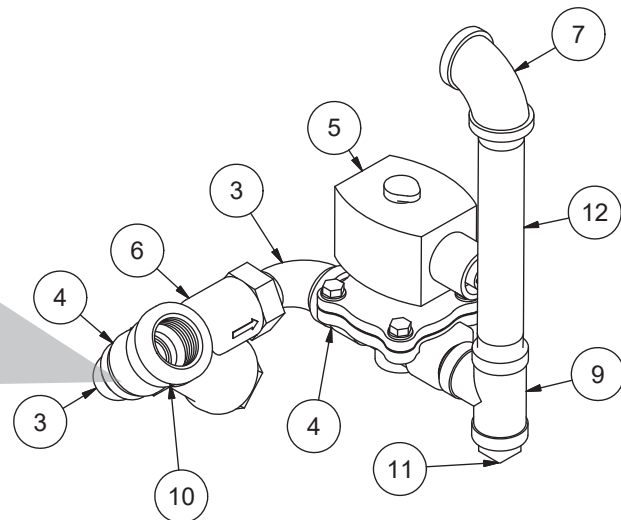
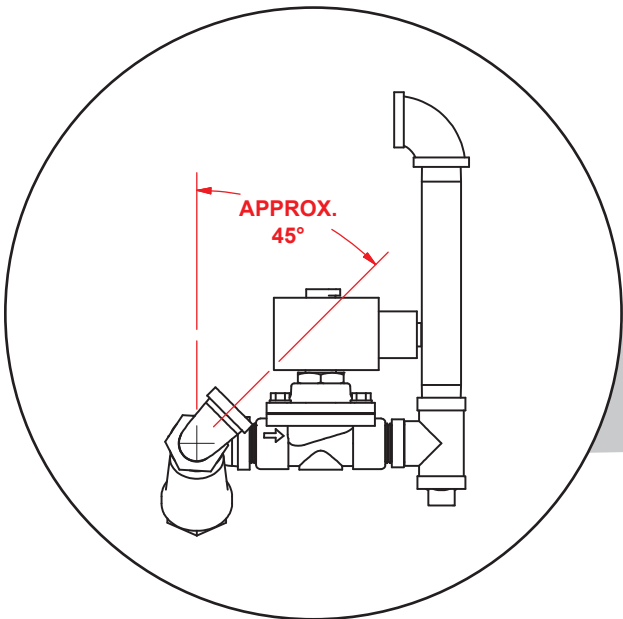
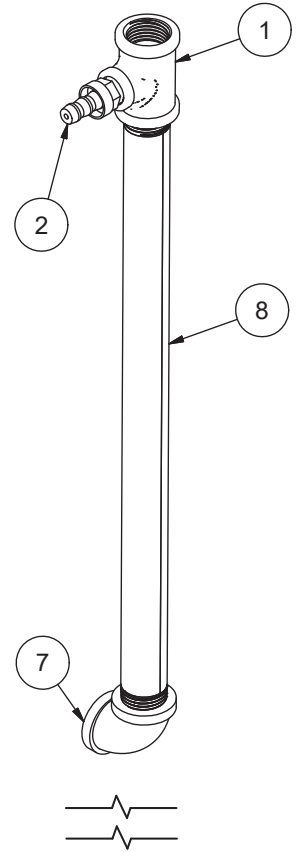
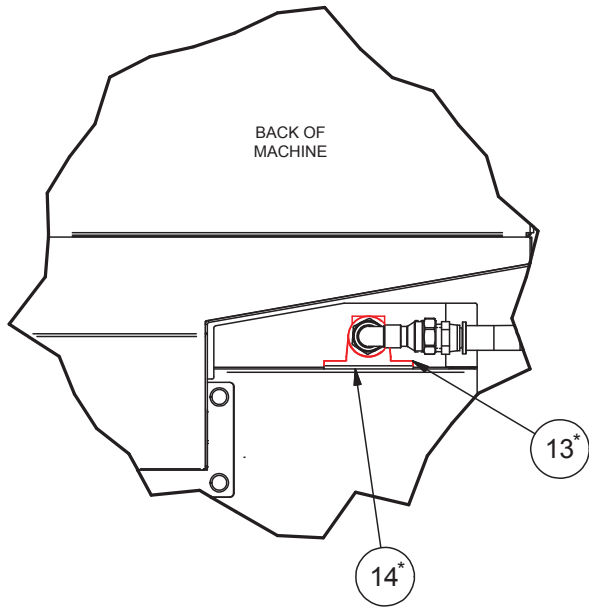

ITEM	QTY	DESCRIPTION	PART NUMBER
	1	Plumbing, HH-E-VER, Complete Assembly	05700-004-52-07
1	1	Tee, 1/2" x 1/2" x 1/4"	04730-002-22-56
2	1	Fitting, 1/4" Barb, 1/4" Swivel	04730-011-95-41
3	2	Elbow, 90-degree, 1/2" Street Brass	04730-206-08-00
4	3	Nipple, 1/2" Close Brass	04730-207-15-00
5	1	Solenoid Valve, 1/2", 208 V	04810-003-71-56
6	1	Y-strainer, 1/2"	04730-217-01-10
7	2	Elbow, 1/2" 90-degree Brass	04730-011-42-96
8	1	Nipple, 1/2" x 1/4" Brass	05700-004-53-43
9	1	Tee, 1/2" Brass	04730-211-27-00
10	1	Coupling, 1/2" x 3/4" Brass	04730-204-07-00
11	1	Plug, 1/2" Brass	04730-209-03-00
12	1	Nipple, 1/2" x 6"	04730-003-62-38
13*	1 3	Rinse Injector, VER Plug, Rinse Injector, 1/8" Brass (Not Shown)	09515-004-22-73 04730-209-07-37
14*	1	Gasket, Rinse Injector	05330-111-42-81

**These items are not included in the complete plumbing assembly and must be ordered separately.*

NOTICE

When servicing plumbing components, take care not to damage the threads of each individual item. Damaged threads can cause leaks and loss of pressure, which could adversely affect the performance of the machine. It is strongly recommended that teflon thread tape, used in conservative amounts, be applied to threads when joining components together. It is not advised to use thread-sealing compounds, sometimes referred to as "pipe dope." Compounds can be ejected from the threads during the tightening process and become lodged in key components, rendering them useless.

NOTICE

*Machines before
18C355287 have
different plumbing.
Click [here](#) to open
earlier manual.*

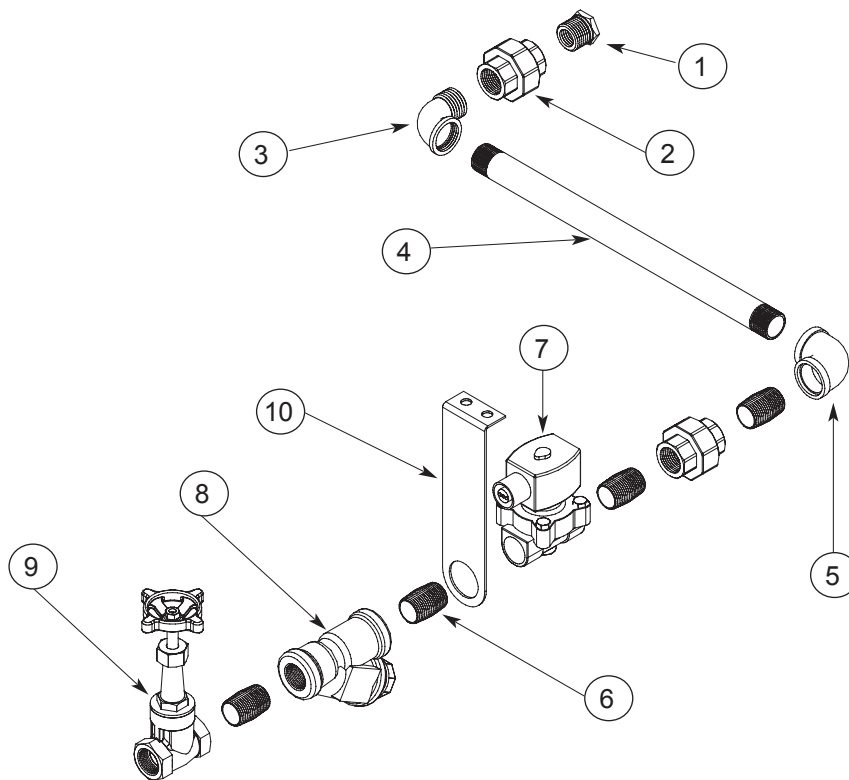
**NOTICE**

When servicing plumbing components, take care not to damage the threads of each individual item. Damaged threads can cause leaks and loss of pressure, which could adversely affect the performance of the machine. It is strongly recommended that teflon thread tape, used in conservative amounts, be applied to threads when joining components together. It is not advised to use thread-sealing compounds, sometimes referred to as "pipe dope." Compounds can be ejected from the threads during the tightening process and become lodged in key components, rendering them useless.

ITEM	QTY	DESCRIPTION	PART NUMBER
	1	Inlet Plumbing, HH Steam, Complete Assembly	05700-002-01-60
1	1	Bushing, Reducing, 3/4" to 1/2"	04730-911-02-34
2	2	Union, 3/4" Black Iron	04730-912-01-00
3	1	Elbow, 90-degree Street, Black Iron	04730-011-87-37
4	1	Pipe, 3/4" NPT Black Iron	05700-002-20-83
5	1	Elbow, 90-degree 3/4" NPT Black Iron	04730-906-10-34
6	4	Nipple, Close 3/4" Black Iron	04730-907-01-00
7	1	Solenoid Valve, Steam Plumbing, 220 V	04820-002-01-56
8	1	Y-Strainer, 3/4" NPT	04730-217-01-32
9	1	Gate Valve, 3/4" NPT	04820-100-19-00
10	1	Bracket, Steam Plumbing Support	05700-002-01-63

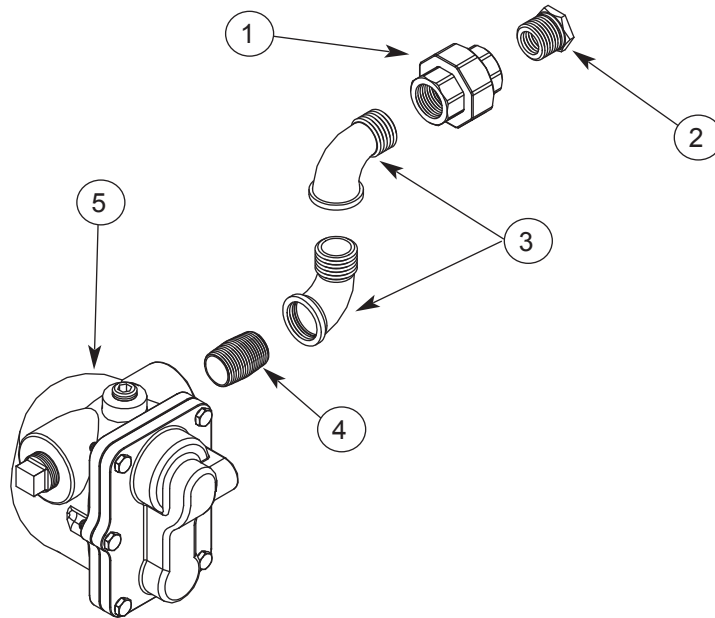
**NOTICE**

When servicing plumbing components, take care not to damage the threads of each individual item. Damaged threads can cause leaks and loss of pressure, which could adversely affect the performance of the machine. It is strongly recommended that teflon thread tape, used in conservative amounts, be applied to threads when joining components together. It is not advised to use thread-sealing compounds, sometimes referred to as "pipe dope." Compounds can be ejected from the threads during the tightening process and become lodged in key components, rendering them useless.

ITEM	QTY	DESCRIPTION	PART NUMBER
	1	Outlet Plumbing, HH Steam, Complete Assembly	05700-002-01-55
1	1	Union, 3/4" NPT, Black Iron	04730-912-01-00
2	1	Bushing, Reducing, 3/4" to 1/2"	04730-911-02-34
3	2	Elbow, 3/4" 90-degree Street	04730-011-87-37
4	1	Nipple, Close, 3/4" NPT, Black Iron	04730-907-01-00
5	1	Steam Trap, 3/4" NPT F&T	06680-500-02-77

Click [here](#) for the Steam Booster manual.



SHOCK ABSORBER (WATER ARRESTOR) OPTION

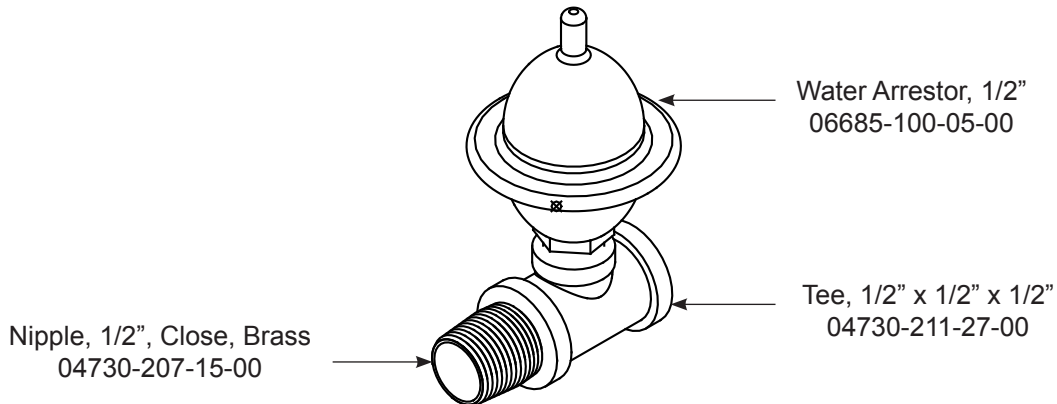

WATER TREATMENT OPTION

Scaltrol System
04730-003-05-76

Replacement Cartridge
(inspect at least every 6 months)
RSC-100

PRESSURE REGULATING VALVE OPTION*

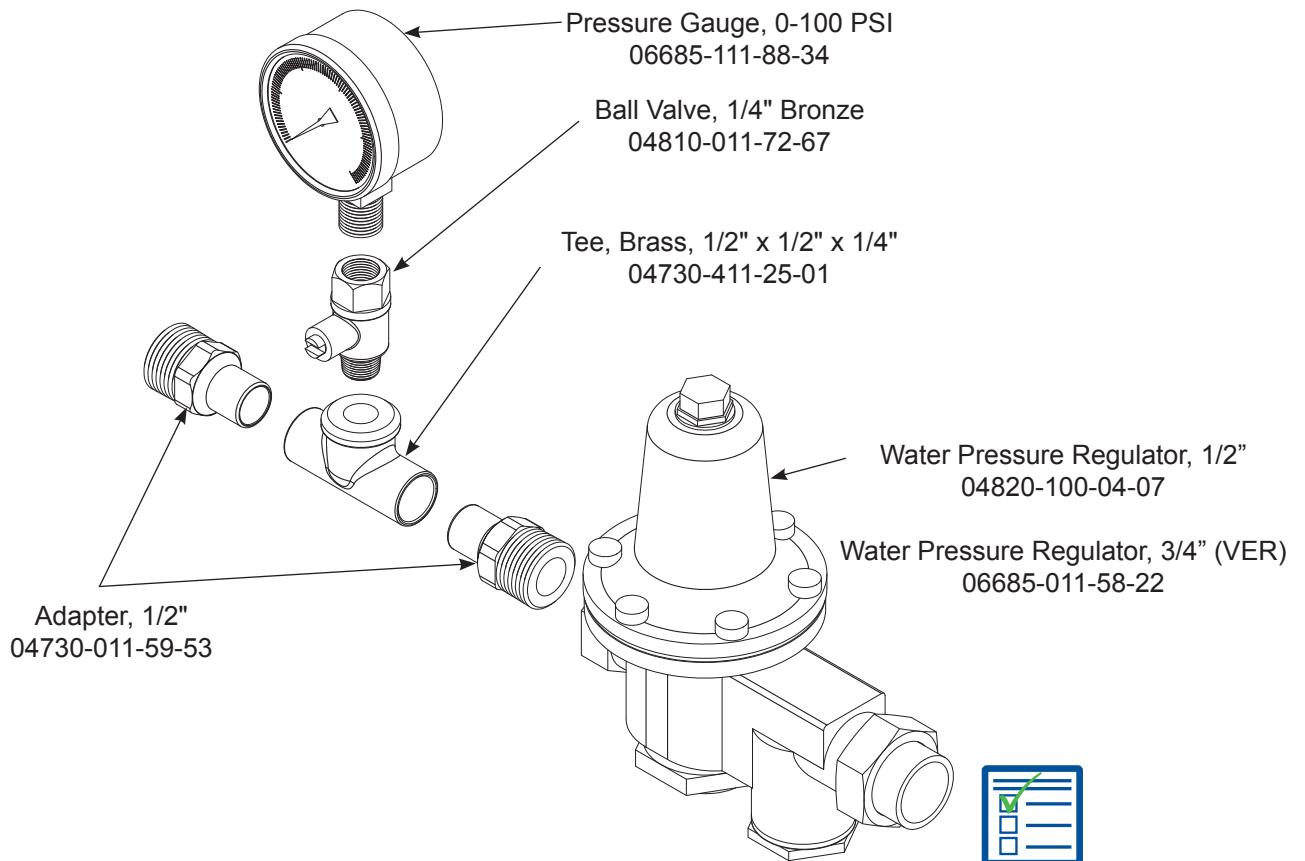

*PRV comes standard on the HH-E-VER but ships inside the machine. Click [here](#) for install instructions.

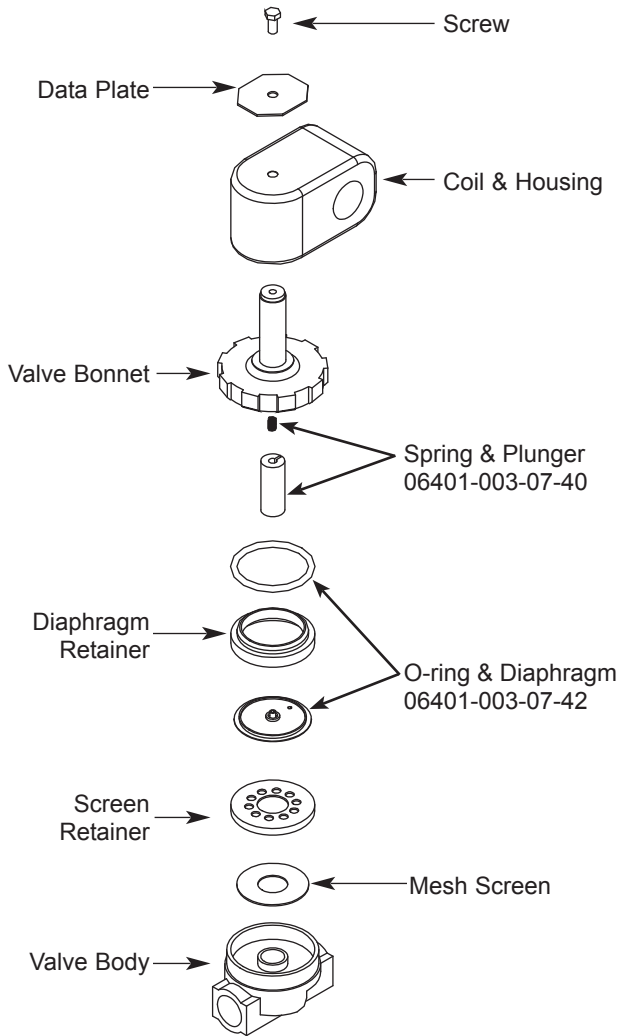

Complete 240 Volt Solenoid Valve Assembly
04810-100-03-18

Coil & Housing only
06401-003-07-44

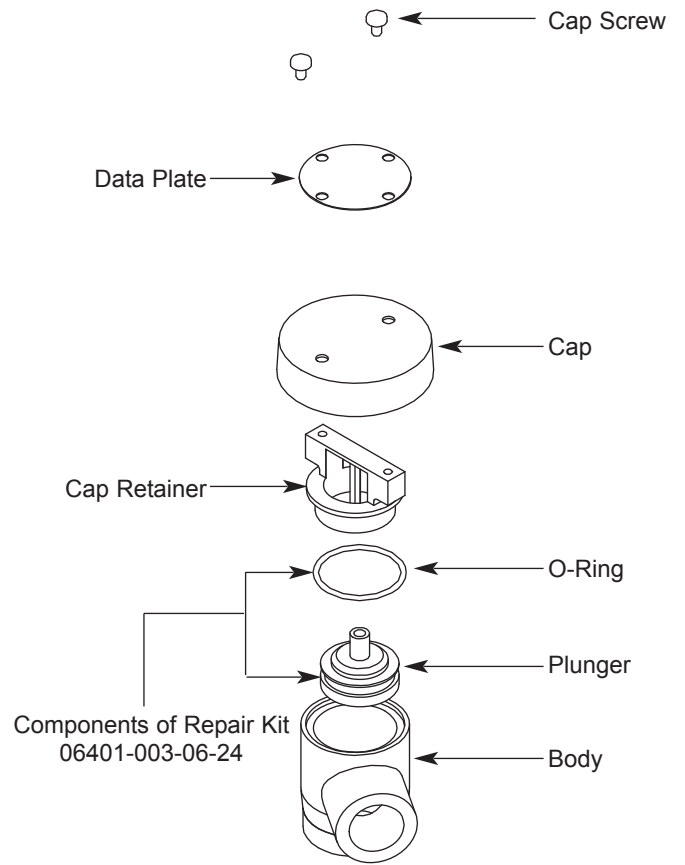

Complete Vacuum Breaker Assembly
04820-002-53-77

RINSE ARMS & MANIFOLD

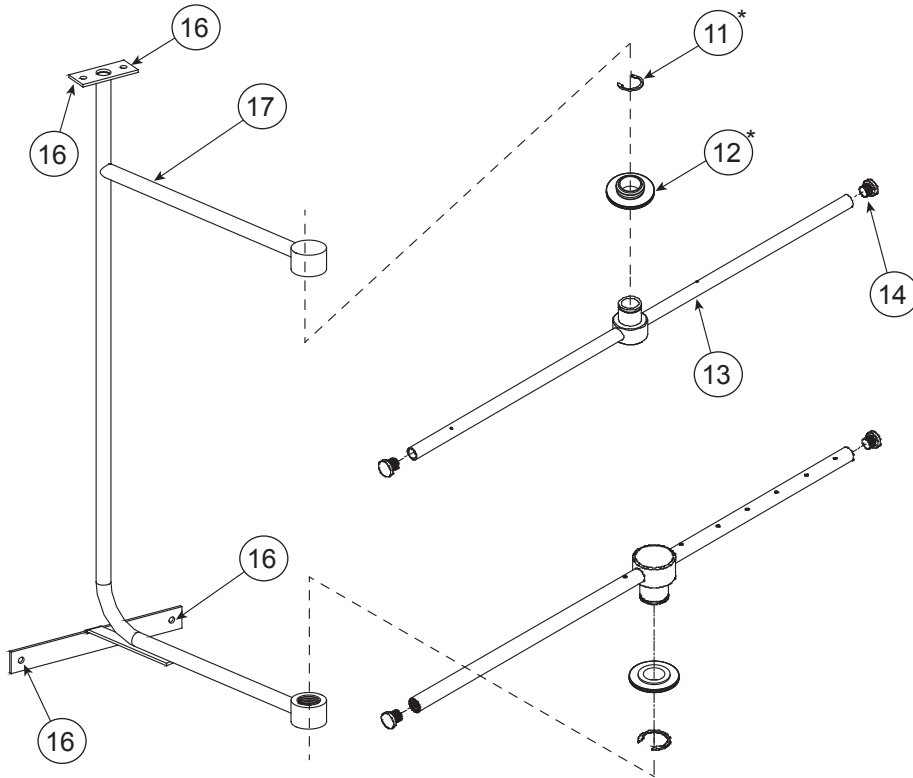

WASH ARMS & MANIFOLD

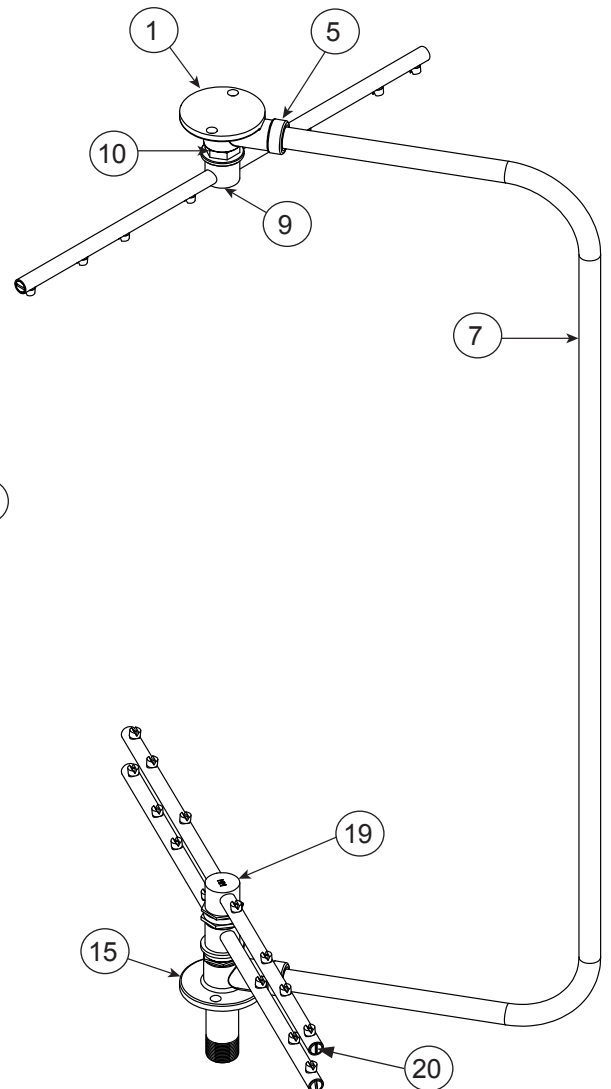
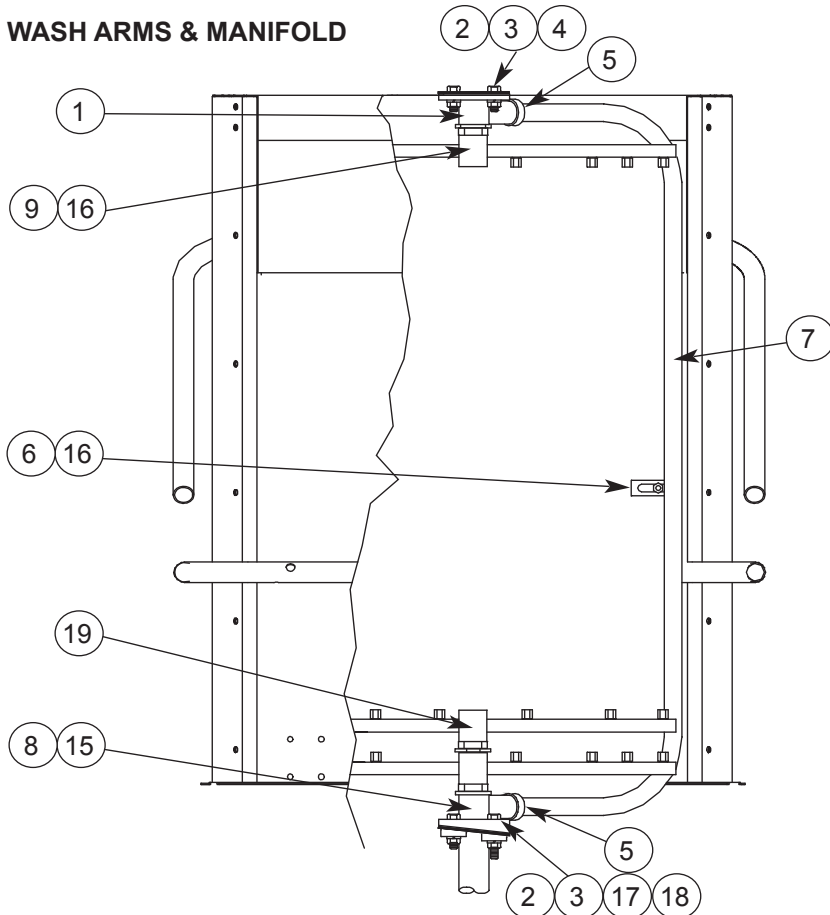

ITEM	QTY	DESCRIPTION	PART NUMBER
1	1	Upper Manifold	05700-031-34-82
2	4	Nut, 3/8-16 Hex	05310-276-01-00
3	4	Lockwasher, 3/8"	05311-276-01-00
4	2	Bolt, Hex 3/8-16 x 7/8"	05306-011-36-95
5	2	O-ring	05330-111-35-15
6	1	Positioning Bracket, Manifold Tube	05700-011-34-63
7	1	Tube, Wash Manifold	05700-031-92-58
8	2	Gasket, Manifold	05700-111-35-03
9	1	Wash Arm Assembly	05700-004-13-13
10	1	Bearing Assembly	05700-021-35-97
11*	2	Clip, Retaining, Rinse Head Bushing	05340-112-01-11
12*	2	Bearing Assembly, Rinse Arm	05700-004-54-71
13	2	Complete Rinse Arm Assembly	05700-004-47-74
	2	Rinse Arm	05700-004-47-56
14	4	Rinse Arm End-cap	04730-111-60-41
15	1	Lower Wash Manifold Weldment	05700-002-21-70
16	5	Locknut, 1/4-20 Hex with Nylon Insert	05310-374-01-00
17	1	Rinse Manifold Weldment	05700-002-01-19
18	2	Bolt, Hex 3/8-16 x 1 1/4"	05305-276-10-00
19	1	Wash Arm, Double Assembly	05700-003-94-00
20	6	Wash Arm End-cap	05700-003-31-59

*Rinse Arm Bearing Kit
(Includes items 11 and 12)
06401-004-57-50

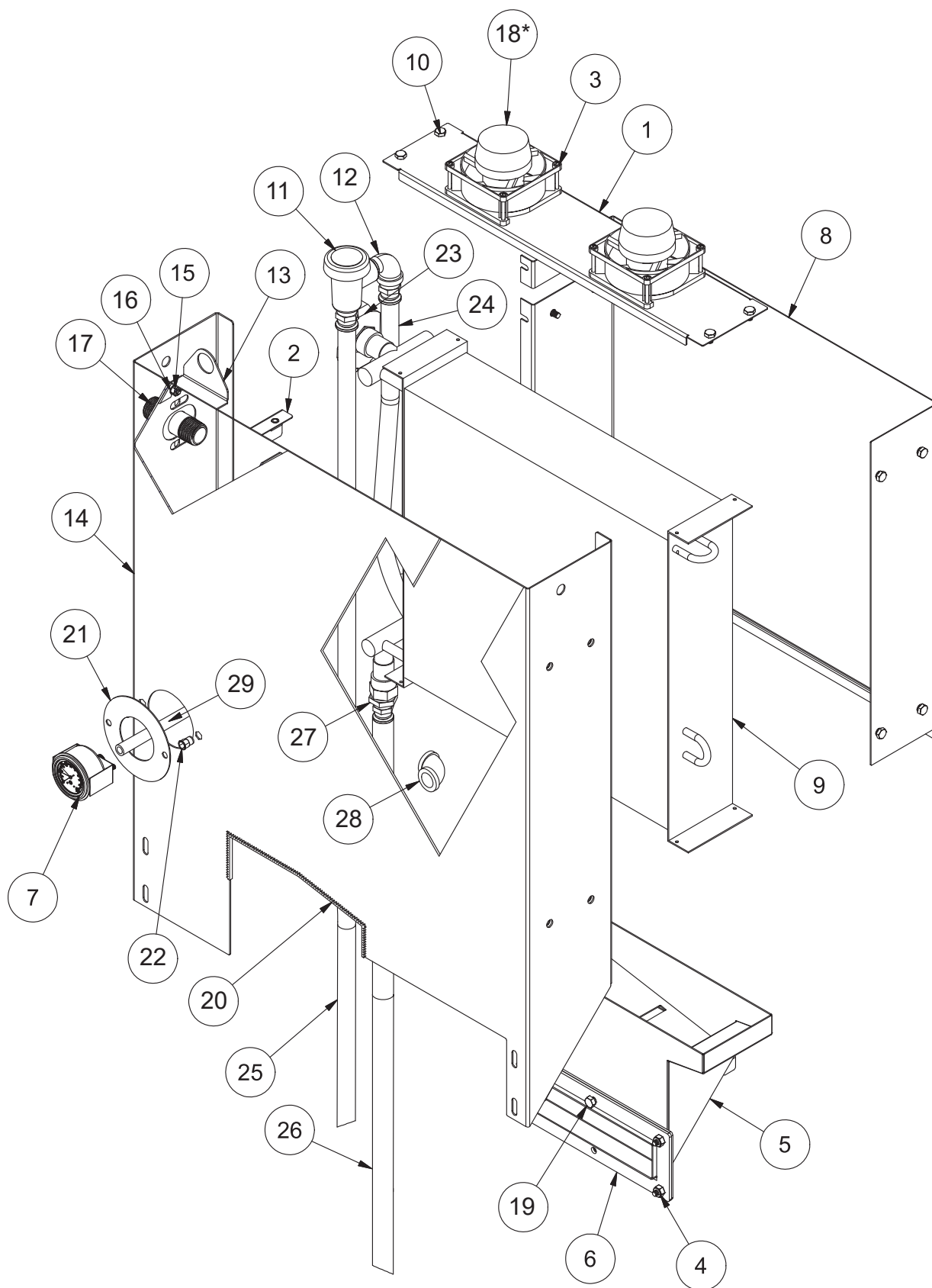

ITEM	QTY	DESCRIPTION	PART NUMBER
	1	VER System, Complete Assembly	05700-004-53-47
1	1	Plate, Fan Mounting	05700-004-18-07
2	1	Upper Shroud	05700-004-18-06
3	8	Screw, 6-32 x 1 3/4"	05305-004-19-80
4	4	Locknut, 1/4-20 Hex with Nylon Insert	05310-374-01-00
5	1	Exhaust Box	05700-004-18-04
6	1	Gasket, Heat Exchanger	05330-004-18-22
7	1	Gauge	06680-004-19-78
8	1	Coil Box, Back	05700-004-18-03
9	1	Coil, Heat Exchanger	04420-004-19-61
10	12	Bolt, 1/4-20 x 3/8" Hex	05305-274-20-00
11	1	Vacuum Breaker, 1/2" Brass	04820-003-06-13
12	1	Elbow, 1/2", 90-degree Street Brass	04730-206-08-00
13	1	Bracket, Vacuum Breaker	05700-004-18-91
14	1	Shroud, Heat Exchanger	05700-004-18-92
15	6	Locknut, 10-24 Hex with Nylon Insert	05310-373-01-00
16	6	Washer, Flat	05311-173-02-00
17	1	Inlet, Cold Water	05700-004-19-01
18*	2	Fan, 85-236 V AC* Fan, 24 V DC*	05999-004-19-46* 05999-004-81-80*
19	2	Screw, 1/4-20 x 5/8" Hex Head	05305-274-24-00
20	1	Edge Protector	05700-004-25-62
21	1	Ring, Pressure Gauge	05700-004-35-70
22	4	Nut, 1/4-20	05310-004-23-96
23	1	Bracket, Water Inlet	05700-004-41-27
24	1	Hose, 1/2" x 24" Red	05700-004-19-89
25	1	Hose, 1/2" x 38" Red	05700-004-31-81
26	1	Hose, 1/2" x 48" Blue	05700-004-48-23
27	1	Bushing, 3/4" x 1/2"	04730-002-56-27
28	1	Elbow, 1/2", 90-degree Brass	04730-011-42-96
29	1	Hose, 1/4" x 30" Black	05700-004-63-75

*Confirm fans are AC or DC before ordering.

ITEM	QTY	DESCRIPTION	PART NUMBER
1	1	Plate, Interlock	05700-004-97-10
2	1	Link, Interlock Connector	05700-004-71-37
3	1	Interlock Cam	05700-004-71-39
4	1	Interlock Guide	05700-004-71-50
5	1	Pin, Interlock	05700-004-71-49
6	1	Motor, Interlock	06105-004-70-04
7	2	Switch, Interlock	05930-004-71-36
8	1	Set Screw, 6-32 x 1/4"	05305-004-71-42
9	2	Shoulder Screw, 10-32	05305-004-71-40
10	2	Screw, 10-32 x 1/2"	05305-011-39-36
11	2	Screw, 6-32 x 3/8"	05305-171-02-00
12	2	Locknut, 10-32 with Nylon Insert	05310-373-02-00
13	5	Locknut, 4-40	05310-279-06-00
14	8	Insert, Threaded Hex 1/4-20	05310-004-23-96
15	2	Bushing, Lock	05975-210-05-00
16	2	Locknut, 6-32 with Nylon Insert	05310-373-03-00
17	1	Box, Door Interlock	05700-004-99-16
18	1	Fitting	05975-011-49-03
19	6	Screw, 1/4-20 x 1/2" Button Head Hex	05305-004-62-33
20	2	Spacer	05700-011-32-79
21	2	Screw, 1/4-20 x 1"	05305-274-27-00

The following instructions are for models equipped with the Door Interlock option. These instructions should only be used if the door interlock fails to unlatch and the door won't open.

1. Turn machine off by flipping the power switch to "OFF."

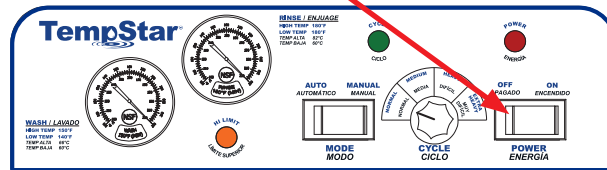

2. If this doesn't disengage the interlock rod, push the rod back by hand.

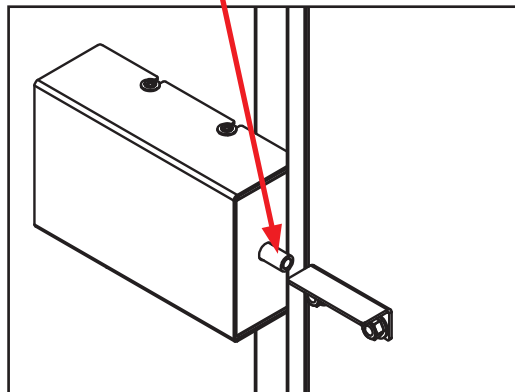

3. The door should now open.
4. Contact a qualified service agency to have the interlock serviced.

460 V MACHINE TRANSFORMER MOUNTING BOX

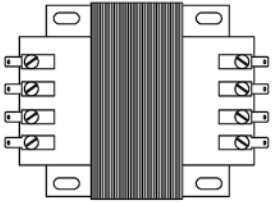

460 V Transformer
05950-111-65-93

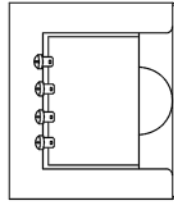

2 A Circuit Breaker
05925-111-64-18

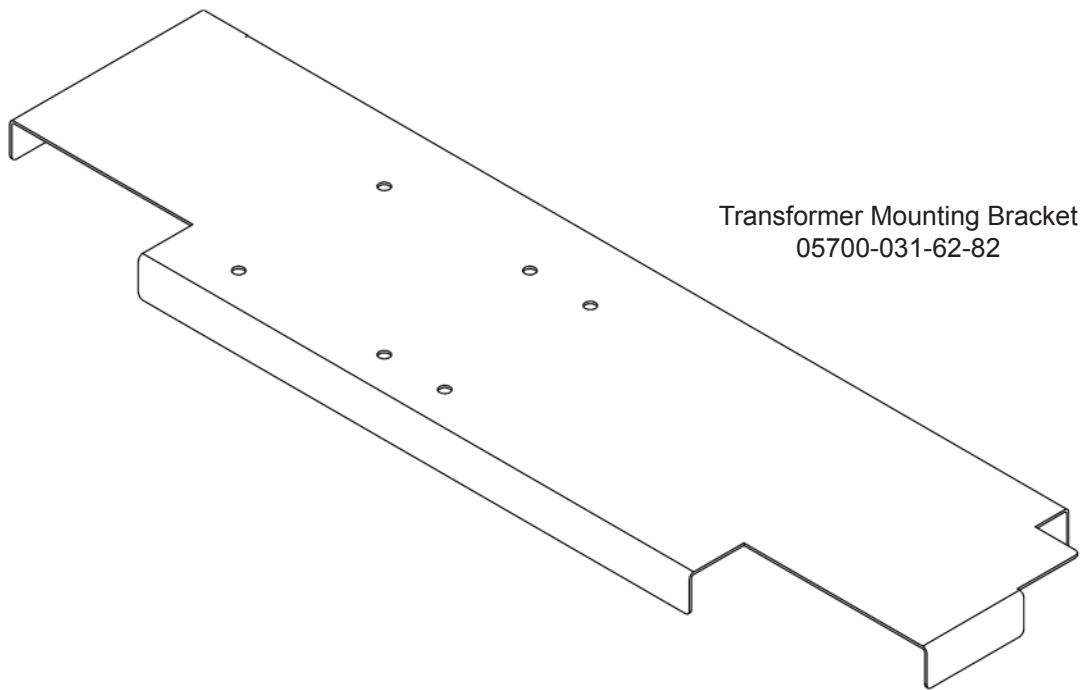
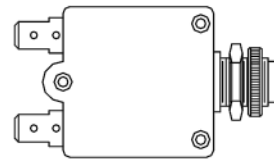

Transformer Mounting Bracket
05700-031-62-82

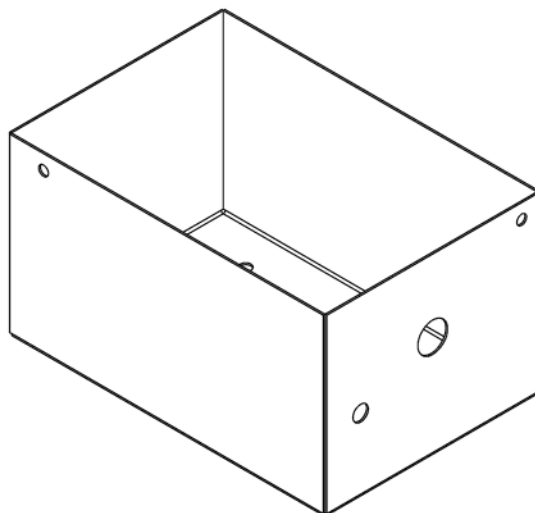

Transformer Mounting Box
05700-002-10-01

Transformer Mounting Box Top
(Not Shown)
05700-000-78-53

Call 1-880-800-5672 to order kits for TempStar HH-E models and use the part numbers below:

DESCRIPTION	PART NUMBER
Door Interlock Kit	06401-004-03-23
Door Magnet Cover Kit	06401-004-07-73
Drain Water Tempering Kit	06401-004-07-86
Exhaust Fan Contactor Kit	05700-004-35-35
False Panel Kit	05700-002-52-89
Phase Conversion Kit	06401-004-00-22
TempStar Go Box Kit*	06401-003-62-04

*The Go Box is a kit of the most-needed parts to successfully complete a repair in the first call 90% or more of the time.

LEGEND

- L1,L2,L3 POWER DISTRIBUTION BLOCK
- GND GROUND
- H1 RINSE HEATER
- H2 WASH HEATER
- M1 WASH MOTOR
- R1 RINSE HEATER CONTACTOR
- R2 WASH HEATER CONTACTOR
- R3 WASH MOTOR CONTACTOR
- R4 CONTROL RELAY
- R5 FILL RELAY
- F1 FUSE, CONSTANT VOLTAGE CONN.
- F2 FUSE, DETERGENT DISPENSER
- F3 FUSE, RINSE DISPENSER
- F4 FUSE, EXHAUST FAN
- S1 POWER SWITCH
- S2 DOOR SWITCH
- S3 AUTO/MANUAL (DELIME) SWITCH
- S4 CYCLE SELECTOR
- E1 POWER LIGHT
- E2 HEATER OVERLOAD LIGHT
- E3 CYCLE LIGHT
- HLTS1 HIGH LIMIT, WASH HEATER
- HLTS2 HIGH LIMIT, RINSE HEATER
- TS1 RINSE HEATER THERMOSTAT
- TS2 WASH HEATER THERMOSTAT
- WFSW1 WASH FLOAT SWITCH 1
- WFSW2 WASH FLOAT SWITCH 2
- FS RINSE/FILL SOLENOID
- UT UNIVERSAL TIMER
- TM EXHAUST FAN TIMER
- PB1 RINSE TEMP PROBE
- PB2 WASH TEMP PROBE
- RF RECOVERY FANS (OPTIONAL)
- DI DOOR INTERLOCK (OPTIONAL)
- SPL SPLICE
- T1 CONTROL TRANSFORMER
- MOL MOTOR OVERLOAD
- CF CONTROL FUSE
- P.S. 24VDC POWER SUPPLY
- R7 VER RECOVERY FAN RELAY

TEMPSTAR & WAREFORCE SCHEMATIC STD/VER/HHE/HHE-VER FL/FL-VER/STD NB/HHE NB

460 VOLTS, 50/60 Hz, 3-PHASE

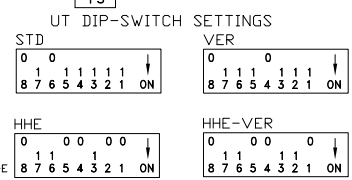
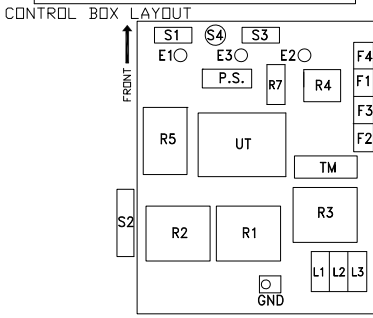
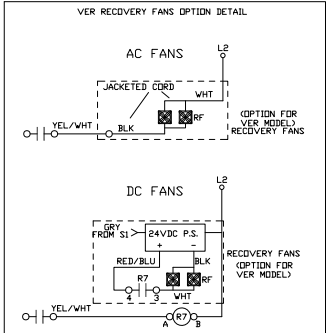
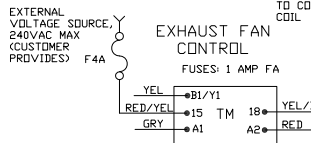
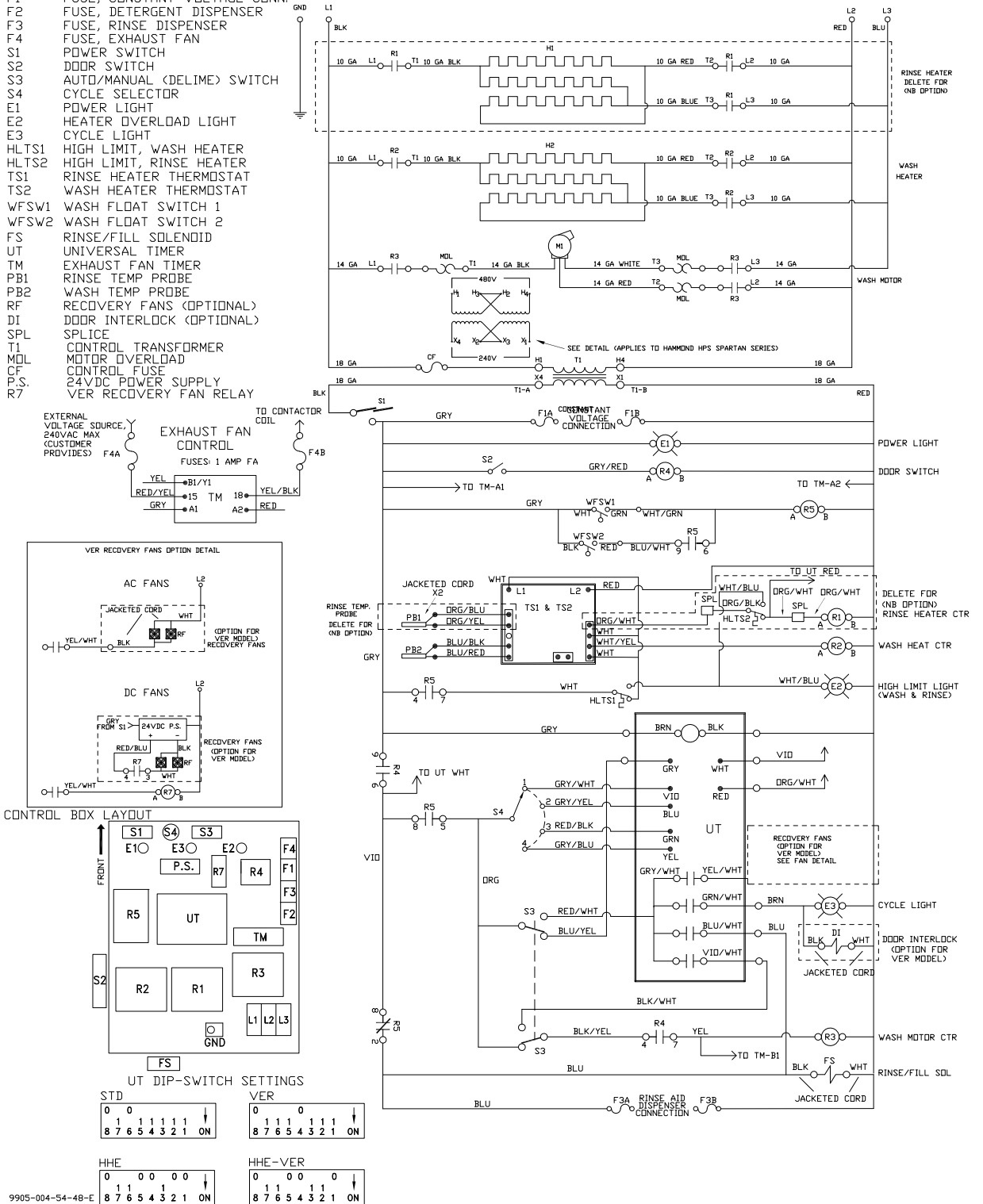

TEMPSTAR SCHEMATIC
STEAM/HH-STEAM

208/230 VOLTS, 50/60 Hz, 1-PHASE

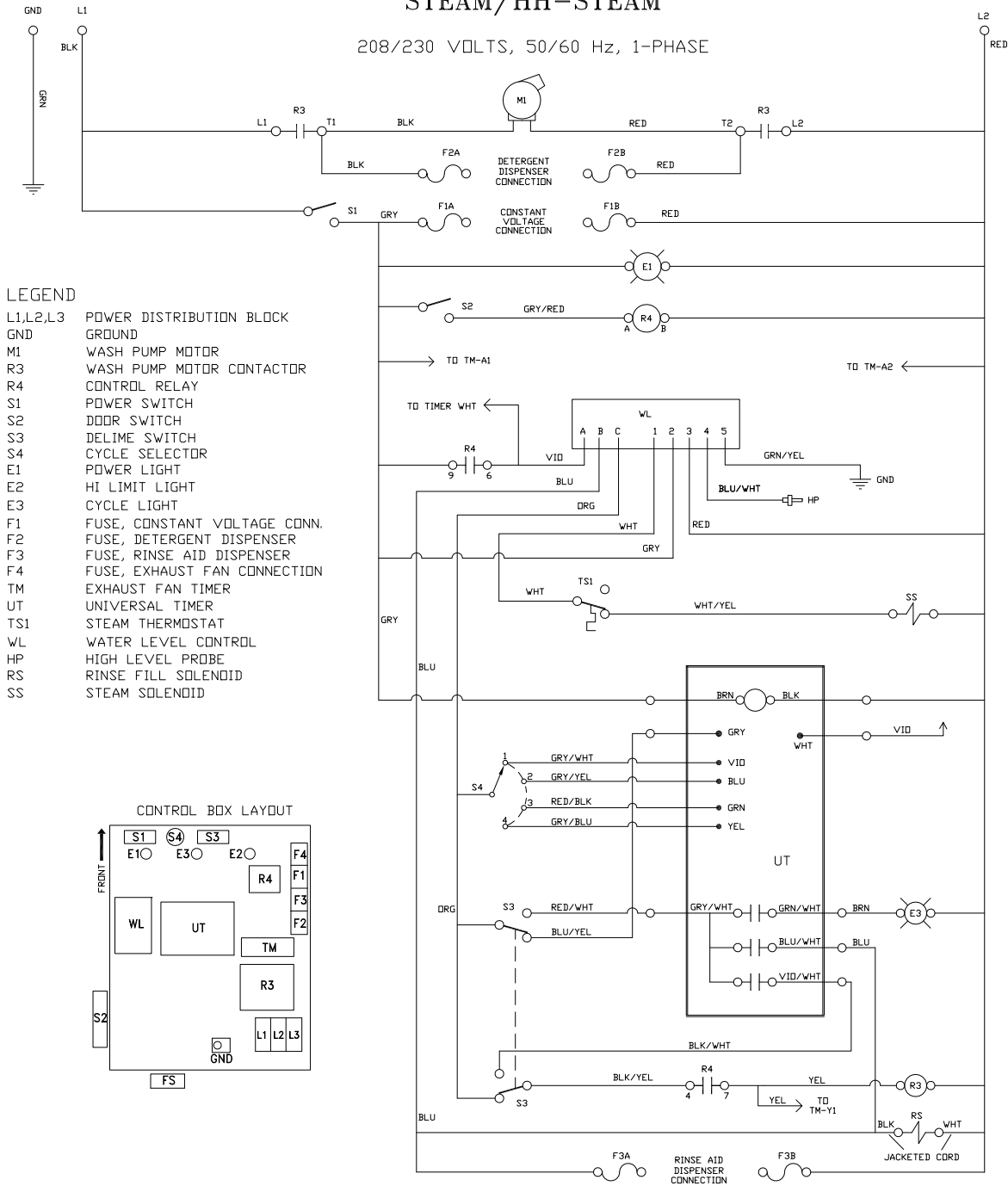

LEGEND

- L1,L2,L3 POWER DISTRIBUTION BLOCK
- GND GROUND
- M1 WASH PUMP MOTOR
- R3 WASH PUMP MOTOR CONTACTOR
- R4 CONTROL RELAY
- S1 POWER SWITCH
- S2 DOOR SWITCH
- S3 DELIME SWITCH
- S4 CYCLE SELECTOR
- E1 POWER LIGHT
- E2 HI LIMIT LIGHT
- E3 CYCLE LIGHT
- F1 FUSE, CONSTANT VOLTAGE CONN.
- F2 FUSE, DETERGENT DISPENSER
- F3 FUSE, RINSE AID DISPENSER
- F4 FUSE, EXHAUST FAN CONNECTION
- TM EXHAUST FAN TIMER
- UT UNIVERSAL TIMER
- TS1 STEAM THERMOSTAT
- WL WATER LEVEL CONTROL
- HP HIGH LEVEL PROBE
- RS RINSE FILL SOLENOID
- SS STEAM SOLENOID

CONTROL BOX LAYOUT

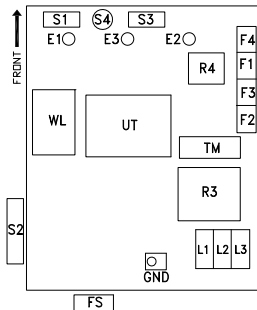

DRAIN QUENCH (OPTION)

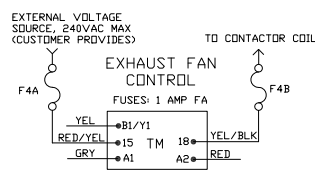
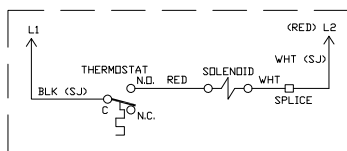

UT DIP-SWITCH SETTINGS

STEAM							
0	0						
1	1	1	1	1	1	1	↓
8	7	6	5	4	3	2	ON

HH-STEAM							
0	1	1	1	0	0		
1	1	1	1	0	0	1	↓
8	7	6	5	4	3	2	ON

TEMPSTAR SDI OPTION FOR 208/230 VAC CIRCUIT

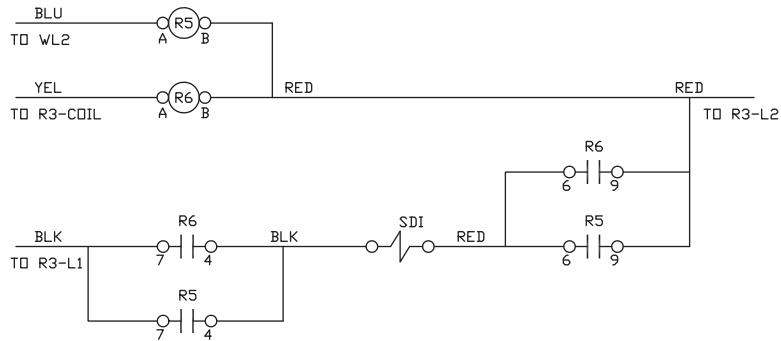

LEGEND

- R5 RELAY, RINSE
- R6 RELAY, WASH
- SDI SOLENOID, SAFETY DOOR INTERLOCK

09905-002-35-85 REV B

TEMPSTAR SDI OPTION FOR 120 VAC CIRCUIT

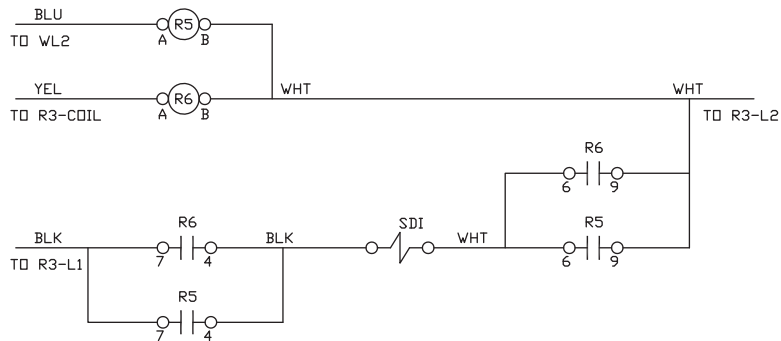

LEGEND

- R5 RELAY, RINSE
- R6 RELAY, WASH
- SDI SOLENOID, SAFETY DOOR INTERLOCK

09905-002-55-78 REV B



Jackson WWS, Inc. • 6209 N. US Hwy 25E • Gray, KY 40734 USA
1.888.800.5672 • www.jacksonwws.com