

Jackson[®]

WAREWASHING SYSTEMS

INSTALLATION, OPERATION, AND SERVICE MANUAL



TEMPSTAR SERIES DOOR-TYPE DISHMACHINES

TempStar Manual • 07610-003-61-42-AA

TEMPSTAR[®]

**MANUFACTURER'S LIMITED WARRANTY
(APPLICABLE ONLY IN THE UNITED STATES AND CANADA)**

WARRANTY REGISTRATION:

To register your Jackson Dishmachine's warranty go to jacksonwws.com/warranty or call 1-888-800-5672. Failure to register the Dishmachine will void the warranty.

ONE YEAR LIMITED PARTS AND LABOR WARRANTY

For a period of one (1) year from date of original installation of a new Jackson Dishmachine (but in no event to exceed eighteen (18) months from date of shipment from Jackson's factory), Jackson WWS, Inc. (Jackson) will repair or replace, at its discretion, any original part that proves defective in materials or workmanship at the time the Dishmachine was purchased; provided that (i) the Dishmachine has not been altered, (ii) the Dishmachine has been properly installed, maintained, and operated under normal use conditions and in accordance with the applicable installation, operation and service manual available on the Jackson website, and (iii) a warranty claim is reported to a Jackson Authorized Service Agency within the warranty period. This warranty includes replacement with Jackson specified genuine replacement parts, purchased directly from a Jackson Authorized Parts Distributor or Service Agency. Use of generic replacement parts may create a hazard and shall void this warranty.

THIS WARRANTY DOES NOT APPLY OUTSIDE THE UNITED STATES AND CANADA.

Jackson will pay the labor to repair or replace a defective original part as a part of the warranty, provided that a Jackson Authorized Service Agency performs the labor. Any repair or replacement work by anyone other than a Jackson Authorized Service Agency is the sole responsibility of the purchaser. Labor coverage is limited to regular hourly rates; Jackson will not pay overtime premiums or emergency service charges.

Accessory components (such as table limit switches, pressure regulators, and drain water tempering kits) that are not installed by Jackson at the factory and are shipped with the Dishmachine carry only a (1) one-year parts warranty. Labor to repair or replace these components is not included in the warranty or covered by Jackson. Booster heaters not manufactured by Jackson are not covered by this warranty but are warranted by their respective manufacturers.

This warranty is void if any defect or failure is a direct result from shipping, handling, fire, water, accident, alteration, modification, misuse, abuse, flood, acts of God, burglary, casualty, attempted repair by unauthorized persons, use of replacement parts not authorized by Jackson, improper installation, installation not in accordance with local electrical and plumbing codes, if the serial number has been removed or altered, if the Dishmachine is used for any purpose other than originally intended, or if the equipment is installed for residential use.

Jackson does not authorize any other entity or person, including, without limitation, any entity or person who deals in Jackson Dishmachines, to change this warranty or create any other obligation in connection with Jackson Dishmachines.

TRAVEL LIMITATIONS:

Jackson limits warranty travel time to the customer site within 50 miles of the Jackson authorized service agent's office and during regular business hours. Jackson will not pay for travel time and mileage that exceeds these limits, or any fees such as those for air or boat travel without prior authorization.

REPLACEMENT PARTS WARRANTY:

For a period of (90) ninety days from the date of installation by a Jackson Authorized Service Agency (but in no event to exceed (180) one-hundred-eighty days from the date of purchase from a Jackson Authorized Parts Distributor or Service Agency), Jackson will repair or replace, at its discretion, any Jackson genuine replacement parts that prove defective in materials or workmanship at the time the replacement parts were installed. This warranty does not include paying the labor to repair or replace the replacement part. This warranty is subject to all conditions, exclusions and limitations applicable to the Dishmachine.

**MANUFACTURER'S LIMITED WARRANTY (CONT.)
(APPLICABLE ONLY IN THE UNITED STATES AND CANADA)**

PRODUCT CHANGES:

Jackson reserves the right to make changes in design and specification of any component of the Dishmachine as engineering or necessity requires.

DISCLAIMER OF WARRANTIES:

THERE ARE NO WARRANTIES, EXPRESSED OR IMPLIED, INCLUDING, WITHOUT LIMITATION, ANY IMPLIED WARRANTY OF FITNESS FOR A PARTICULAR PURPOSE OR MERCHANTABILITY, THAT ARE NOT SET FORTH HEREIN, OR THAT EXTEND BEYOND THE DURATION HEREOF.

LIMITATION OF REMEDIES AND LIABILITIES:

YOUR SOLE AND EXCLUSIVE REMEDY UNDER THIS LIMITED WARRANTY SHALL BE PRODUCT REPAIR OR REPLACEMENT AS PROVIDED HEREIN.

UNDER NO CIRCUMSTANCES WILL JACKSON BE LIABLE FOR ANY INCIDENTAL OR CONSEQUENTIAL DAMAGES, OR FOR DAMAGES IN THE NATURE OF PENALTIES. JACKSON'S LIABILITY ON ANY CLAIM OF ANY KIND WITH RESPECT TO THE GOODS OR SERVICES COVERED HEREUNDER SHALL IN NO CASE EXCEED THE PRICE OF THE GOODS OR SERVICES OR PART THEREOF WHICH GIVES RISE TO THE CLAIM.

ITEMS NOT COVERED:

THIS WARRANTY DOES NOT COVER (1) ADJUSTMENTS INCLUDING, BUT NOT LIMITED TO, TIMER CAMS, THERMOSTATS, DOORS, TANK HEATER ADJUSTMENTS OR CLUTCHES; (2) AIR FREIGHT OR OVERNIGHT FREIGHT; (3) ANY AMOUNT EXCEEDING ORIGINAL PURCHASE PRICE; (4) CLEANING OF DRAIN VALVES, GAS LINES, RINSE/WASH NOZZLES, STRAINERS, SCREENS, OR SPRAY PIPES; (5) CLEANING OR DELIMING OF THE DISHMACHINE OR ANY COMPONENT INCLUDING, BUT NOT LIMITED TO, WASH ARMS, RINSE ARMS AND STRAINERS; (6) CONDITIONS CAUSED BY THE USE OF INCORRECT (NON-COMMERCIAL) GRADE DETERGENTS; (7) CORROSION FROM CHEMICALS DISPENSED IN EXCESS OF RECOMMENDED CONCENTRATIONS; (8) COSMETIC DAMAGE, INCLUDING BUT NOT LIMITED TO, SCRATCHES, DENTS, CHIPS, AND OTHER DAMAGE TO THE DISHMACHINE FINISHES, UNLESS SUCH DAMAGE RESULTS FROM DEFECTS IN MATERIALS AND WORKMANSHIP AND IS REPORTED TO JACKSON WITHIN (30) THIRTY DAYS FROM THE DATE OF INSTALLATION; (9) DAMAGE CAUSED BY LABOR DISPUTE; (10) DAMAGES RESULTING FROM IMPROPER CONNECTION TO UTILITY SERVICE; (11) DAMAGES RESULTING FROM WATER CONDITIONS, INADEQUATE OR EXCESSIVE WATER PRESSURE, ACCIDENTS, ALTERATIONS, IMPROPER USE, ABUSE, HANDLING, OVERLOADS, TAMPERING, IMPROPER INSTALLATION OR FAILURE TO FOLLOW MAINTENANCE AND OPERATING PROCEDURES; (12) DISCOLORATION, RUST OR OXIDATION OF SURFACES RESULTING FROM CAUSTIC OR CORROSIVE ENVIRONMENTS, INCLUDING, BUT NOT LIMITED TO, HIGH SALT CONCENTRATIONS, HIGH MOISTURE OR HUMIDITY, OR EXPOSURE TO CHEMICALS; (13) ELECTRIC BOOSTERS, FEED LINES, FLEX HOSE, FUSES, GARBAGE DISPOSALS, OR GAS PILOTS; (14) EXCESSIVE LIME, MINERAL, OR ALKALINE BUILDUP; (15) EXPENSES DUE TO DISCONNECTION, DELIVERY, RETURN AND REINSTALLATION; (16) FAILURE OF ELECTRICAL COMPONENTS DUE TO CONNECTION OF CHEMICAL DISPENSING EQUIPMENT INSTALLED BY OTHERS; (17) FAILURE OF FACILITY WATER HEATER TO MAKE TEMPERATURE; (18) FAILURE TO MAINTAIN WATER HARDNESS LOWER THAN 3.0 GRAINS, PH BETWEEN 7.0 AND 8.5 AND TOTAL DISSOLVED SOLIDS BELOW 250 PPM; (19) FAILURE TO COMPLY WITH LOCAL ELECTRICAL BUILDING CODES; (20) LEAKS OR DAMAGE RESULTING FROM SUCH LEAKS CAUSED BY THE INSTALLER, INCLUDING THOSE AT MACHINE TABLE CONNECTIONS, OR BY CONNECTION OF CHEMICAL DISPENSING EQUIPMENT INSTALLED BY OTHERS; (21) OPENING OR CLOSING OF UTILITY SUPPLY VALVES OR SWITCHING OF ELECTRICAL SUPPLY CURRENT; (22) PERFORMANCE OF REGULAR MAINTENANCE AND CLEANING AS OUTLINED IN THE OPERATOR'S GUIDE; (23) REMOVAL OR REINSTALLATION OF INACCESSIBLE DISHMACHINES OR BUILT-IN FIXTURES THAT INTERFERE WITH SERVICING, REMOVAL OR REPLACEMENT OF THE DISHMACHINE; (24) REPLACEMENT WEAR ITEMS INCLUDING, BUT NOT LIMITED TO, CURTAINS, DRAIN BALLS, DOOR GUIDES, GASKETS, O-RINGS, SEALS, SQUEEZE TUBES, AND BEARINGS; (25) RESIDENTIAL USE; (26) USE WITH UTILITY SERVICE OTHER THAN THAT DESIGNATED ON THE RATING PLATE.

REVISION HISTORY

Revision	Date	Made by	Process	Details
A-S	N/A	N/A	N/A	See earlier revision of manual for revisions A-S.
T	1-11-16	JH	QOF-386	Changed item 12 on pg. 35 to 05700-003-07-76. Added 05700-004-23-78 and 05700-004-23-79 to view (pg. 31) and parts list (pg. 32).
U	3-14-17	JH	N/A	Added dimensions for notch cut into table on corner installations pg. 4. Corrected total amps and typical electrical circuit for 230 V, 50 Hz, 1 Phase LT/NB machines on pg. 7 to 35 A and 40 A, respectively. Corrected P/N for item 6 on pgs. 36 and 39. Changed item 19 to item 17 in Tube Length Chart on pg. 51. Changed valve (item 15) view and P/N to 04810-003-71-56 on pgs. 51 and 52. Changed valve (item 7) view and P/N to 04810-003-71-56 on pg. 53. Removed views that showed pressure regulator in certain locations. Created Plumbing Options, pg. 54, with the pressure regulator and arrestor as options. Added wash arm end-cap as item #21 to pg. 58. Added external device wiring instructions. Added instructions for programming new exhaust fan timer. Added rinse arm bearing replacement instructions. Updated schematics. Changed name of delime switch throughout from NORMAL/DELIME to AUTO/MANUAL. Updated Delime Instructions and added instructions for low-temp machine. Added water level probe cleaning to the Shutdown and Cleaning section. Updated to new manual format. Audited and corrected all P/Ns in the manual.
V	9-24-18	JH	8392 8480 8533 8536 8567 8576 8599	Added: links to exhaust fan timer instructions, Chemical Connections section, Motor Rotation section, new exhaust fan timer, fuses, page for new rinse tank, new phase conversion kit, list of applicable kits, and new rinse tank schematics. Changed: steam pressure to 10-30 PSI, P/N for contactor item #4 on pg. 25, rinse arm bearing assembly, rinse arm bearing kit P/N. Replaced thermostat and components with solid state thermostat and components. Updated: electrical requirements, pgs. 6-7, motor P/Ns, heater P/Ns, plumbing to new rinse tank plumbing, VER plumbing to new rinse tank plumbing, pg. 54-55 with new view and parts list.
W	3-24-21	JH	N/A	Removed LT from manual. Added 50 Hz models to Electrical Requirements section. Added VER System Assembly section. Included resistance-to-temperature table. Changed gauge P/N on VER System page and added item #21. Updated drain water tempering kit P/N on Kits page.
X	7-5-22	JH	8748	Added power supply and relay to Control Box pages (used on machines with door interlock and VER machines with DC fans). Added DC fan to VER System pages with note on models affected. Updated applicable schematics to show AC and DC fans.
Y	4-11-23	JH	8893 22-1424	Added FL and FL-VER models. Inserted scaltrol graphic into Water Supply Connection section. Updated latent and sensible heat values. Changed P/N of relay for door interlock. Updated plumbing section to identify all parts. Updated schematics.
Z	8-22-23	JH	N/A	Added: thermistor and union to booster, new door interlock, and links to previous revisions (LLC vs. float). Updated note on VER fans.
AA	6-26-25	JH	24-2513	Added: plug to booster, link back to earlier manual in door interlock section, o-ring to wash and rinse arm assemblies, relay to control box for VER units, and 6" minimum clearance above VER system to drawings. Corrected balloon numbers on frame page. Moved probe and fitting to back of booster. Removed 460 V motor o-ring (uses same as 208 V) and steam models/associated pages. Updated: rinse injector P/N, tub fitting P/N, VER assembly instructions, universal timer P/N, and disconnect power decal P/N.



TempStar®

Door-type dishmachine; ENERGY STAR® qualified, electrically-heated, high-temp, hot-water sanitizing, with booster heater.

TempStar® FL

Door-type dishmachine; front-loading, ENERGY STAR® qualified, electrically-heated, high-temp, hot-water sanitizing, with booster heater.

TempStar® NB

Door-type dishmachine; electrically-heated, high-temp, hot-water sanitizing, with no rinse booster.

TempStar® VER

Door-type dishmachine; electrically-heated, high-temp, hot-water sanitizing, with booster heater and ventless energy recovery system.

The manufacturer provides technical support for all of the dishmachines detailed in this manual. We strongly recommend that you refer to this manual before making a call to our technical support staff. Please have this manual open when you call so that our staff can refer you, if necessary, to the proper page. Technical support is not available on holidays.

Contact technical support toll free at 1-888-800-5672.

Technical support is available for service personnel only.

TABLE OF CONTENTS

GUIDES

Symbols.....	1
Abbreviations & Acronyms.....	1

SPECIFICATIONS

TempStar/NB Dimensions	2
TempStar FL Dimensions	3
TempStar VER Dimensions	4
TempStar FL-VER Dimensions	5
Table Dimensions	6
Operating Parameters	7
Electrical Requirements	8

INSTALLATION

Installation Instructions.....	10
<i>Inspection</i>	10
<i>Unpacking</i>	10
<i>VER System Assembly</i>	10
<i>Leveling</i>	14
<i>Plumbing</i>	14
<i>Water Supply Connection</i>	14
<i>Pressure Regulator</i>	15
<i>Shock Absorber</i>	15
<i>Connecting the Drain Line</i>	15
<i>Exhaust Fan Timer</i>	15
<i>Chemical Connections</i>	16
<i>Plumbing Check</i>	16
<i>Electrical Power Connections</i>	17
<i>Motor Rotation</i>	18
<i>Voltage Check</i>	18
<i>Surrounding Area</i>	18
<i>Temperature Setpoints</i>	18
<i>False Panel/Corner Install</i>	18

OPERATION

Operating Instructions	19
<i>Preparation</i>	19
<i>Power Up</i>	19
<i>Filling the Wash Tub</i>	19
<i>Ware Preparation</i>	19
<i>Daily Machine Preparation</i>	19
<i>Warm-Up Cycles</i>	20
<i>Washing a Rack of Ware</i>	20
<i>Operational Inspection</i>	20
<i>Shutdown & Cleaning</i>	20
<i>VER Coil Cleaning</i>	22

TABLE OF CONTENTS

OPERATION

Detergent Control	23
Delimiting	24

MAINTENANCE

Preventative Maintenance	25
--------------------------------	----

TROUBLESHOOTING

Troubleshooting	26
-----------------------	----

PARTS

Control Box	28
Hood	33
Hood - FL/FL-VER	34
Door & Arm	35
Door - FL/FL-VER	38
Tub	40
Frame	46
Rinse Tank	47
Motors	49
Heaters	51
TempStar/FL Plumbing	53
Plumbing - NB Models	55
Plumbing - VER/FL-VER	58
Plumbing Options	59
Wash & Rinse Assemblies	60
VER System	62
VER Door Interlock	64
FL-VER Door Interlock	66
VER Door Interlock Override	67
460 V Machine Transformer Mounting Box	68
Kits	69

SCHEMATICS

208-230 V	70
460 V	71
NB, 208-230 V	72
NB, 460 V	73
SDI Options	75

GUIDES

SYMBOLS



- Risk of Injury to Personnel



- Risk of Damage to Equipment



- Risk of Electrical Shock



- Caustic Chemicals



- Reference Data Plate



- Lockout Electrical Power

NOTICE - Important Note



- Instructions Hyperlink

ABBREVIATIONS & ACRONYMS

- ANSI** - American National Standards Institute
- Btu/Hr** - British Thermal Units per Hour
- CFM** - Cubic Feet per Minute
- GHT** - Garden Hose Thread
- GPH** - Gallons per Hour
- GPM** - Gallons per Minute
- GPG** - Grains per Gallon
- HP** - Horsepower
- Hz** - Hertz
- ID** - Inside Diameter
- kW** - Kilowatts
- MCA** - Minimum Circuit Ampacity
- MOP** - Maximum Overcurrent Protection
- NFPA** - National Fire Protection Association
- NPT** - National Pipe Thread
- OD** - Outside Diameter
- PRV** - Pressure Regulating Valve
- PSI** - Pounds per Square Inch
- V** - Volts

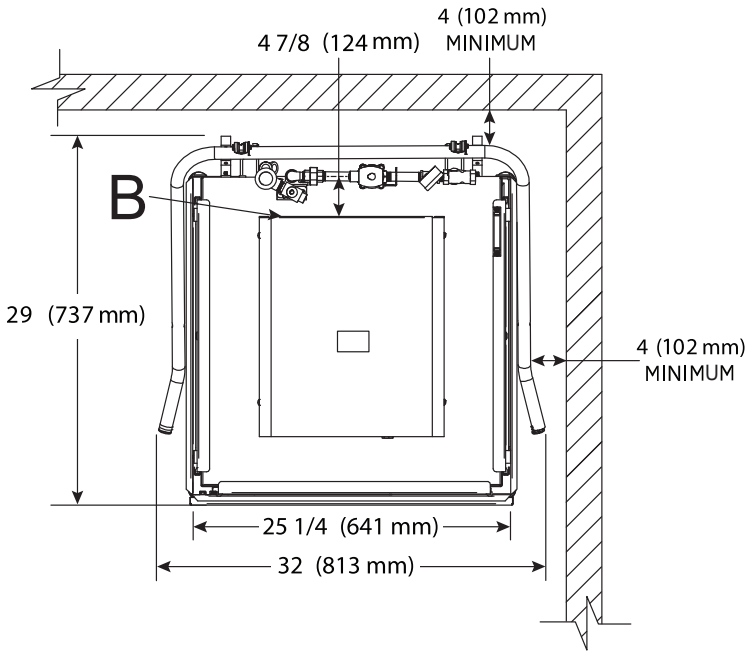

LEGEND

- A - Water Inlet (1/2" NPT)
- B - Electrical Connection Point
- C - Drain (1 1/2" NPT)

All dimensions from the floor can be increased 1 1/8" using the machine's adjustable feet.

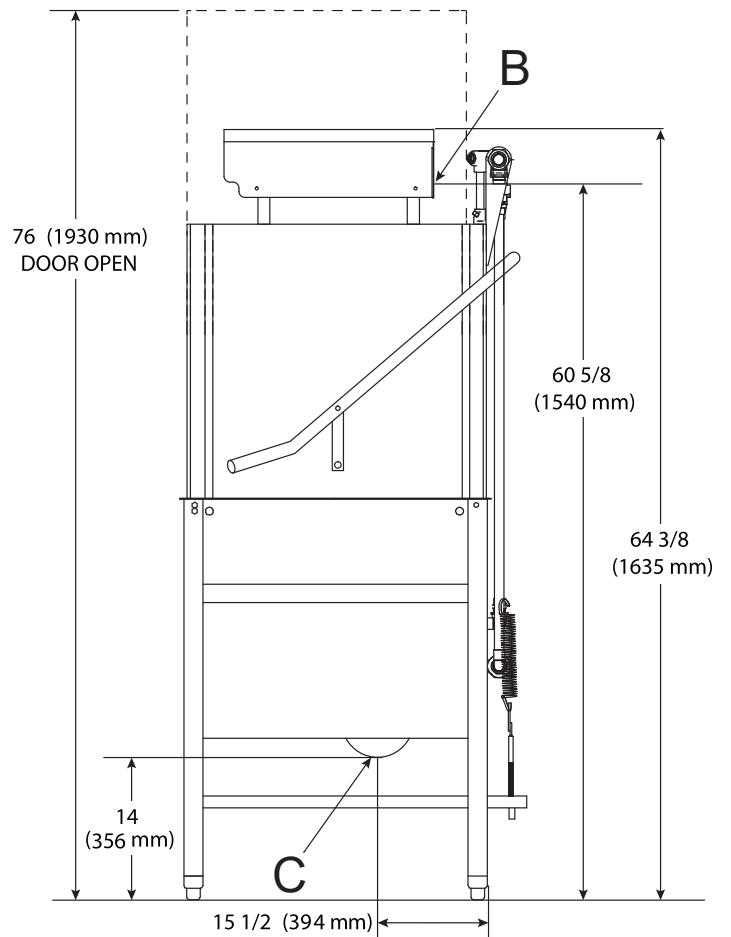
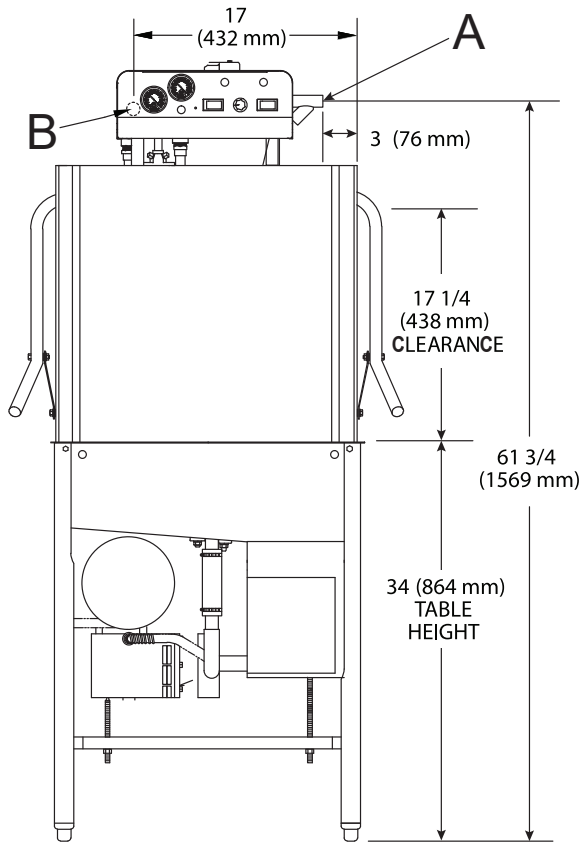

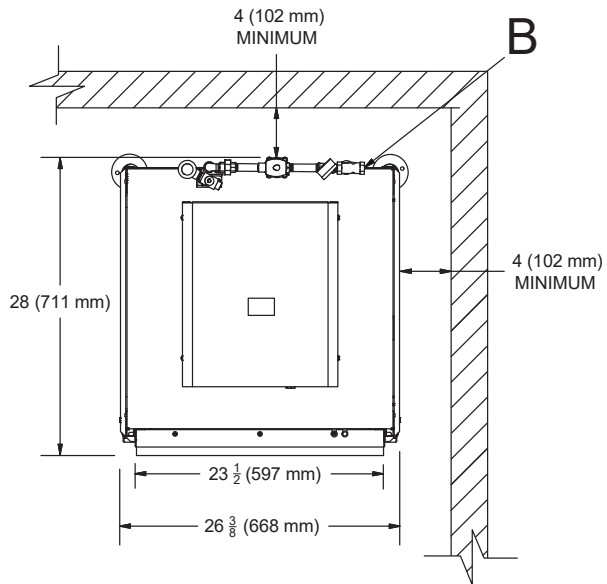

LEGEND

- A - Drain (1 1/2" NPT)
- B - Water Inlet (3/4" NPT)
- C - Electrical Connection

All dimensions from the floor can be increased 1 1/8" using the machine's adjustable feet.

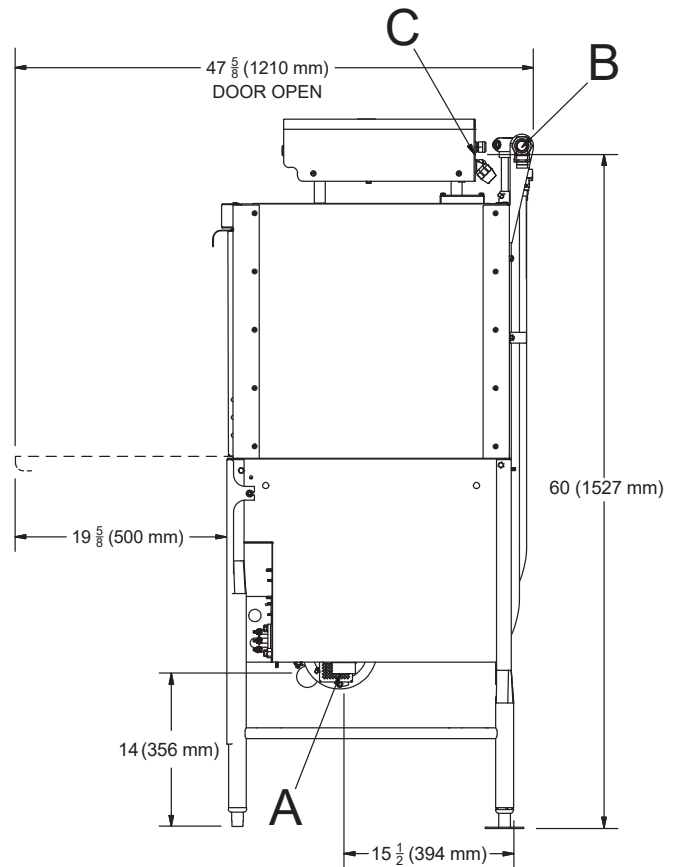
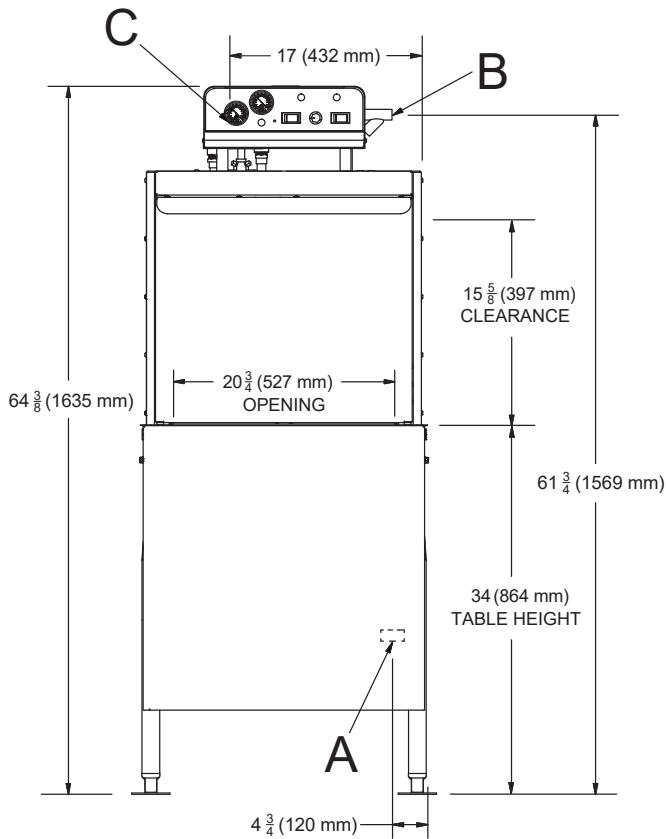

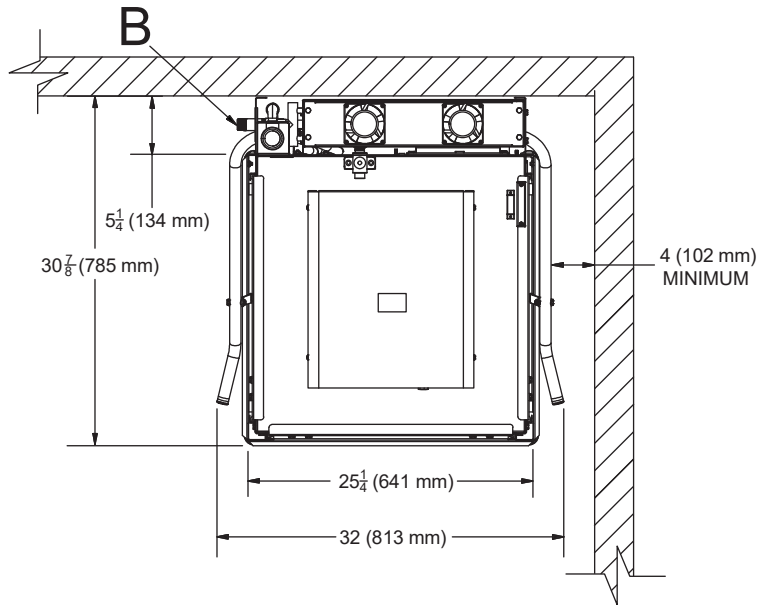

LEGEND

- A - Drain (1 1/2" NPT)
- B - Water Inlet (3/4" NPT)
- C - Electrical Connection

All dimensions from the floor can be increased 1 1/8" using the machine's adjustable feet.

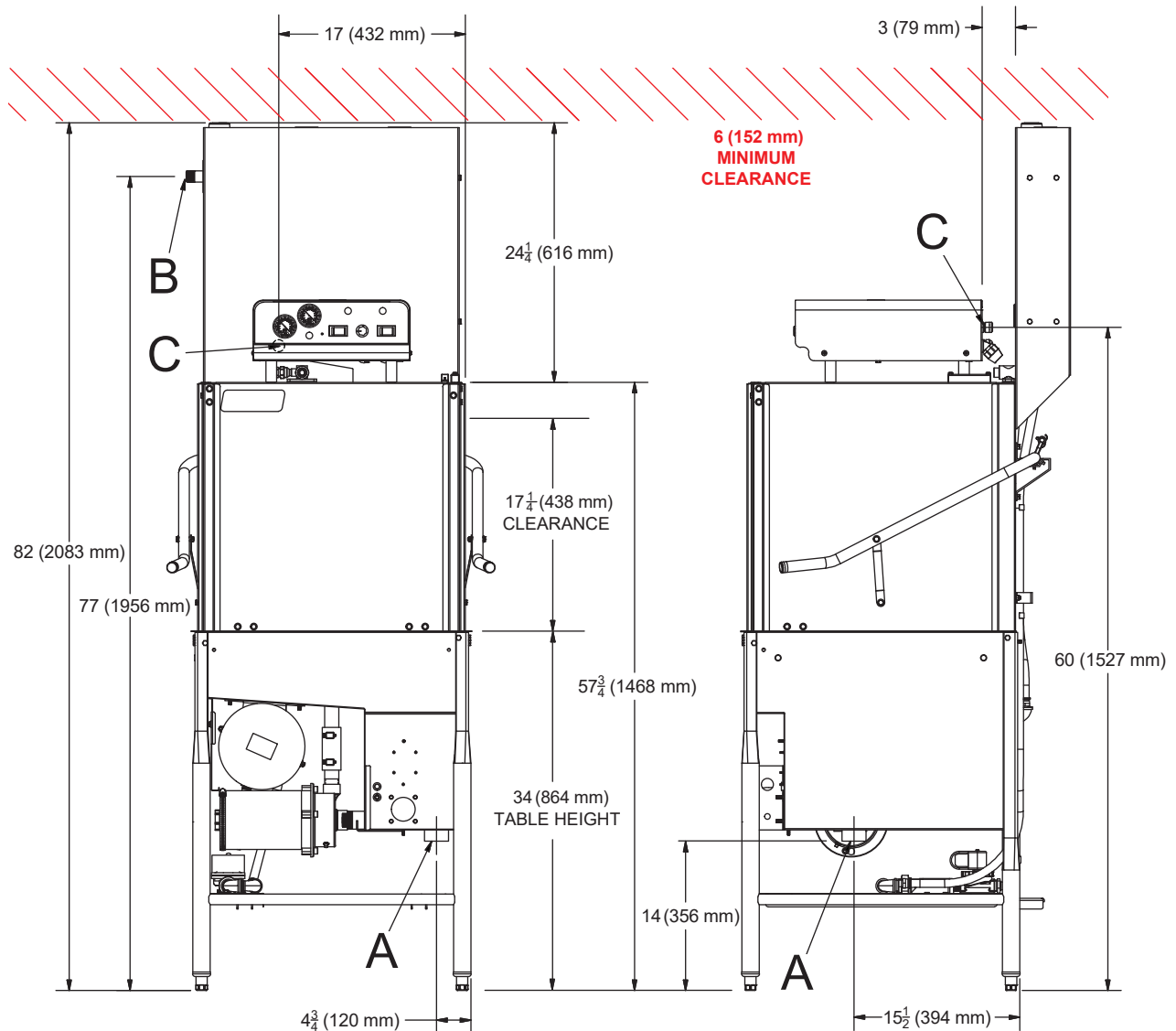

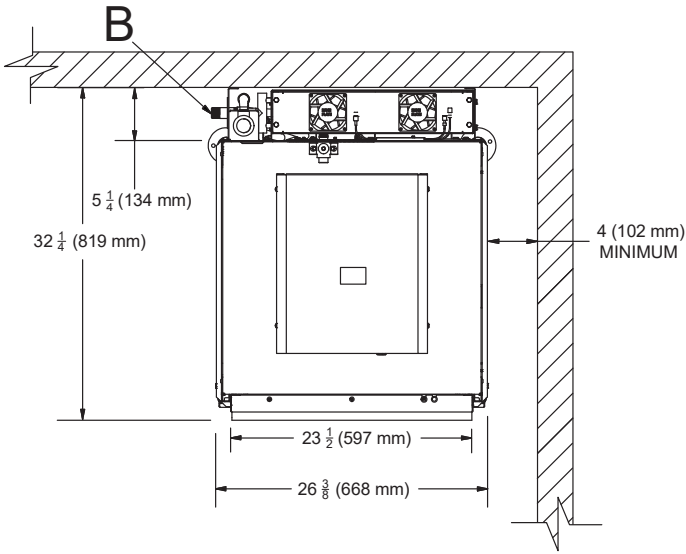

LEGEND

- A - Drain (1 1/2" NPT)
- B - Water Inlet (3/4" NPT)
- C - Electrical Connection

All dimensions from the floor can be increased 1 1/8" using the machine's adjustable feet.

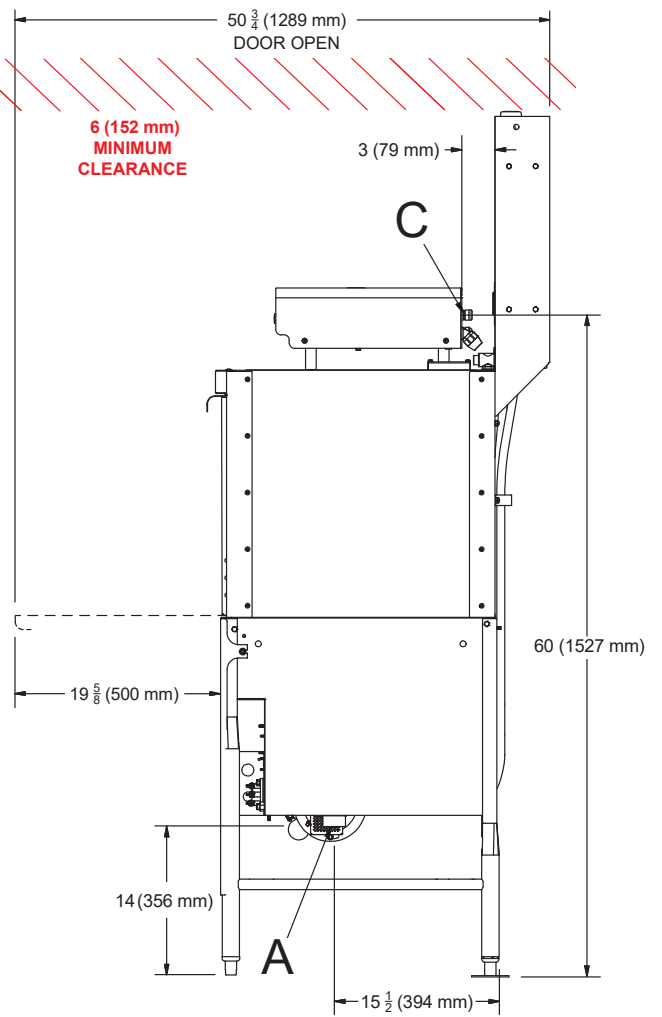
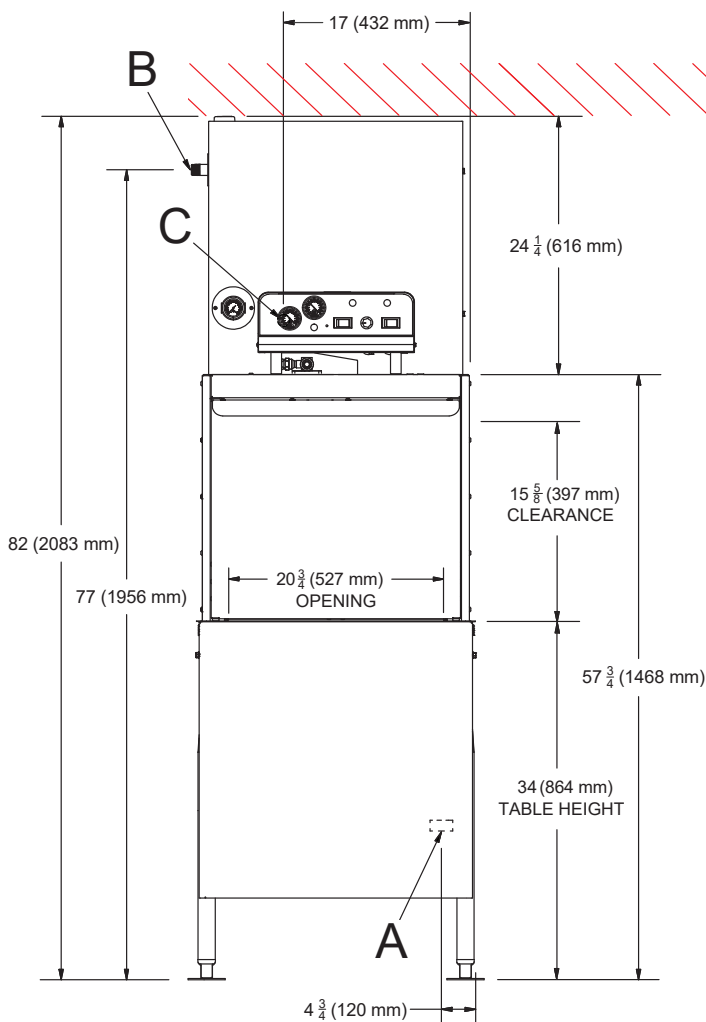

CORNER INSTALLATION

For corner install instructions:

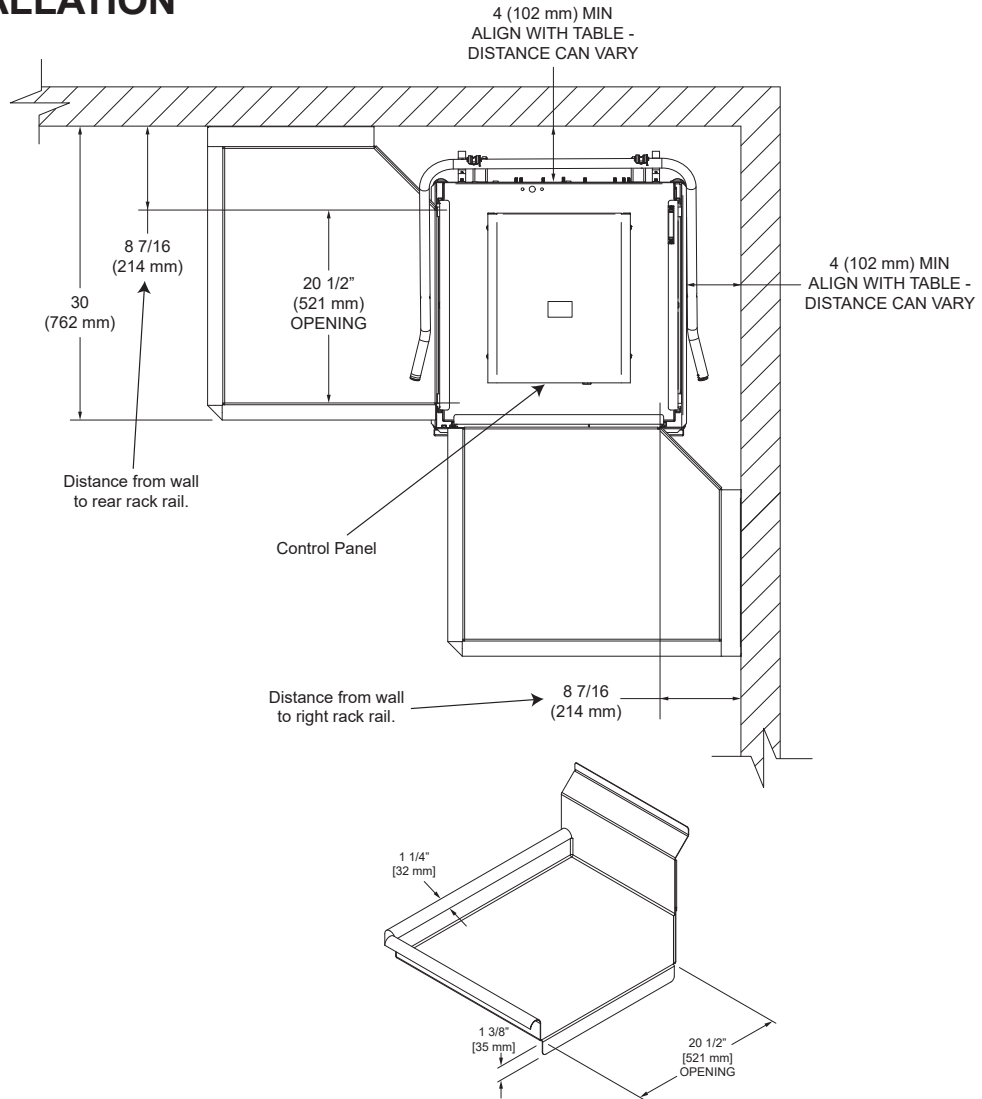

STRAIGHT-THROUGH INSTALLATION

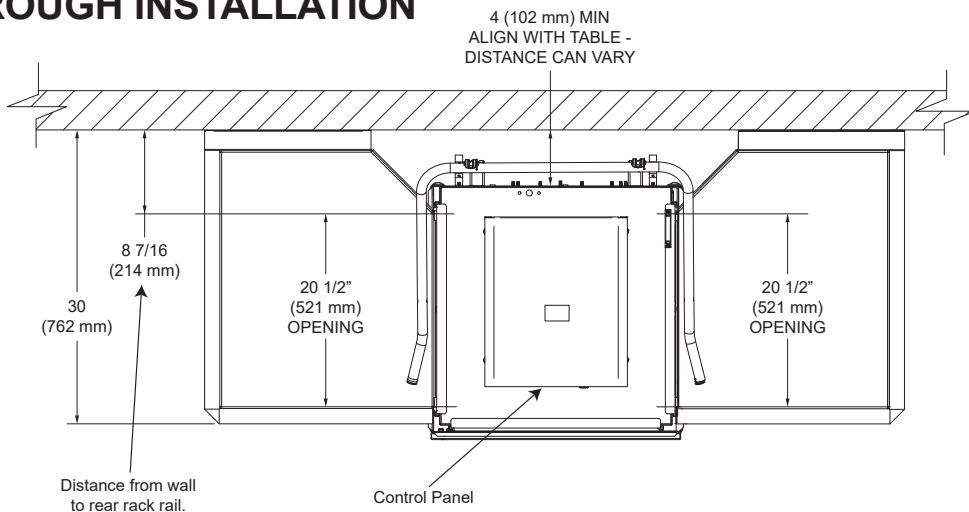

PERFORMANCE/CAPABILITIES

Operating Capacity:

TempStar/FL/NB

Racks per Hour	63 (58*) (41**)
Dishes per Hour	1575
Glasses per Hour	2268

VER/FL-VER

Racks per Hour	41 (39*) (30**)
Dishes per Hour	1025
Glasses per Hour	1476

Minimum Operating Cycle (seconds):

TempStar/FL/NB

Wash Time	40
Rinse Time	13
Dwell Time	4
Total Cycle Time	57

VER/FL-VER

Wash Time	40
Rinse Time	13
Dwell Time	4
Condensate Removal	30
Total Cycle Time	87

Tank Capacity (gallons/liters):

Wash Tank	8.0/30.3
Rinse Tank	2.0/7.6

WATER REQUIREMENTS

TempStar/FL/VER/FL-VER

Minimum Wash Temperature (°F/°C)	150/66
Minimum Rinse Temperature (°F/°C)	180/83
Inlet Water Temperature:	
12 kW Rinse Heater (°F/°C)	140/60
14 kW Rinse Heater (°F/°C)	110/44
VER/FL-VER (°F/°C)	40-90/4.4-32.2
Flow Pressure (PSI)	10 ± 2
Water Line Size	1/2"
Water Line Size (VER)	3/4"
Drain Line Size	1 1/2"

NB

Minimum Wash Temperature (°F/°C)	150/66
Minimum Rinse Temperature (°F/°C)	180/83
Inlet Water Temperature (°F/°C)	180/83
Flow Pressure (PSI)	10 ± 2
Water Line Size	1/2"
Drain Line Size	1 1/2"

ENERGY SPECIFICATIONS

VER/FL-VER

Latent Heat	6326 Btu/Hr
Sensible Heat	4685 Btu/Hr

NOTICE



Always refer to the machine data plate for specific electrical and water requirements. The material provided on this page is for reference only and is subject to change without notice.

*Racks per hour calculated with NSF-suggested load time of :05 for door-type dishmachines (straight-through).

**Racks per hour for FL and FL-VER calculated with NSF-suggested load time of :30 for front-opening dishmachines.

Local codes may require more stringent protection than what is displayed here and on the data plate. Always verify with your electrical service contractor that your circuit protection is adequate and meets all applicable national and local codes. Numbers in this manual are for reference and may change without notice. On three-phase machines, imbalanced wild leg goes to L3. Also see the Motor Rotation section.



TempStar/FL 70° Rise (14 kW) & VER/FL-VER

Volts	Phase	Freq	Wash Motor	Wash Heater	Rinse Heater	Total Load	MCA	MOP
208	3	60 Hz	5.0 A	11.4 A	29.2 A	45.6 A	46.9 A	50 A
230	3	60 Hz	5.0 A	12.6 A	32.3 A	49.9 A	51.2 A	55 A
460	3	60 Hz	1.24 A	6.3 A	16.1 A	23.7 A	24.0 A	25 A
208	1	60 Hz	5.0 A	19.7 A	50.6 A	75.3 A	76.6 A	80 A
230	1	60 Hz	5.0 A	21.8 A	55.9 A	82.7 A	84.0 A	90 A
208	3	50 Hz	7.8 A	11.4 A	29.2 A	48.4 A	50.3 A	55 A
230	3	50 Hz	7.8 A	12.6 A	32.3 A	52.6 A	54.6 A	60 A
380	3	50 Hz	1.7 A	8.3 A	21.3 A	31.3 A	31.7 A	35 A
415	3	50 Hz	1.7 A	7.6 A	14.6 A	23.8 A	24.3 A	25 A
208	1	50 Hz	7.8 A	19.7 A	50.6 A	78.0 A	80.0 A	85 A
230	1	50 Hz	7.8 A	21.8 A	55.9 A	85.5 A	87.4 A	95 A

TempStar/FL 40° Rise (12 kW)

Volts	Phase	Freq	Wash Motor	Wash Heater	Rinse Heater	Total Load	MCA	MOP
208	3	60 Hz	5.0 A	11.4 A	25.0 A	41.4 A	42.7 A	45 A
230	3	60 Hz	5.0 A	12.6 A	27.7 A	45.3 A	46.6 A	50 A
460	3	60 Hz	1.24 A	6.3 A	13.8 A	21.4 A	21.7 A	25 A
208	1	60 Hz	5.0 A	19.7 A	43.3 A	68.0 A	69.3 A	70 A
230	1	60 Hz	5.0 A	21.8 A	47.9 A	74.7 A	76.0 A	80 A
208	3	50 Hz	7.8 A	11.4 A	25.0 A	44.2 A	46.1 A	50 A
230	3	50 Hz	7.8 A	12.6 A	27.7 A	48.0 A	50.0 A	55 A
380	3	50 Hz	1.7 A	8.3 A	31.6 A	41.6 A	42.0 A	45 A
415	3	50 Hz	1.7 A	7.6 A	21.6	30.9 A	31.3 A	35 A
208	1	50 Hz	7.8 A	19.7 A	43.3 A	70.8 A	72.8 A	80 A
230	1	50 Hz	7.8 A	21.8 A	47.9 A	77.5 A	79.4 A	85 A

Local codes may require more stringent protection than what is displayed here and on the data plate. Always verify with your electrical service contractor that your circuit protection is adequate and meets all applicable national and local codes. Numbers in this manual are for reference and may change without notice. On three-phase machines, imbalanced wild leg goes to L3. Also see the Motor Rotation section.



TempStar NB

Volts	Phase	Freq	Wash Motor	Wash Heater	Total Load	MCA	MOP
208	3	60 Hz	5.0 A	11.4 A	16.4 A	17.7 A	20 A
230	3	60 Hz	5.0 A	12.6 A	17.6 A	18.9 A	20 A
460	3	60 Hz	1.24 A	6.3 A	7.5 A	7.8 A	15 A
208	1	60 Hz	5.0 A	19.7 A	24.7 A	26.0 A	30 A
230	1	60 Hz	5.0 A	21.8 A	26.8 A	28.1 A	30 A
208	3	50 Hz	7.8 A	11.4 A	19.2 A	21.1 A	25 A
230	3	50 Hz	7.8 A	12.6 A	20.4 A	22.3 A	30 A
380	3	50 Hz	1.7 A	8.3 A	10.0 A	10.4 A	15 A
415	3	50 Hz	1.7 A	7.6 A	9.3 A	9.7 A	15 A
208	1	50 Hz	7.8 A	19.7 A	27.5 A	29.4 A	35 A
230	1	50 Hz	7.8 A	21.8 A	29.6 A	31.5 A	35 A

INSPECTION

Before installing the machine, check packaging and machine for damage. If packaging is damaged, the machine might also be damaged. If there is damage to both packaging and machine, do not throw away the packaging. The machine has been inspected and packed at the factory and is expected to arrive in new, undamaged condition. However, rough handling by carriers or others might result in damage to the machine while in transit. If so, do not return the machine to the manufacturer. Instead, contact the carrier and ask them to send a representative to the site to inspect the damage and complete an inspection report. You must contact the carrier and the dealer within 48 hours of receiving the machine.

Do not throw away packaging if damage is evident!

UNPACKING

Unpack the machine and ensure there are no missing parts. If an item is missing, contact the manufacturer immediately. VER system for VER/FL-VER models ships in separate packaging and must be installed before proceeding with machine installation.

VER SYSTEM ASSEMBLY

1. Ensure hoses are connected to VER system.

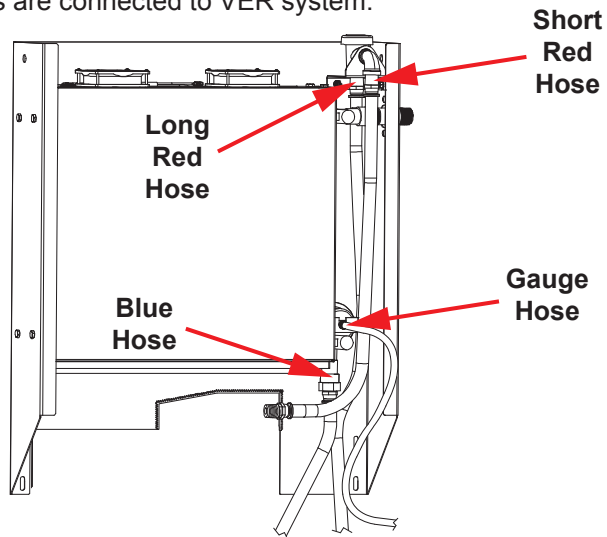

2. Locate bag inside the machine with four 1/4-20 bolts. These secure VER system to the machine.

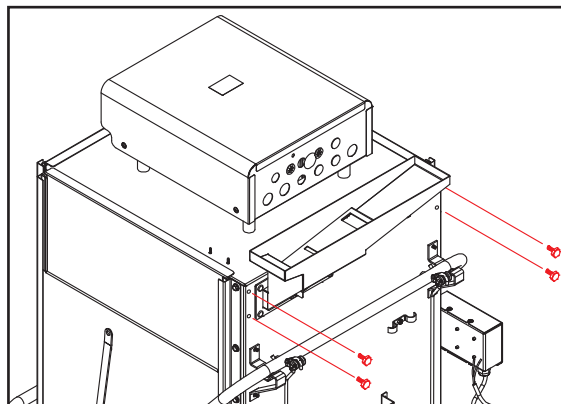

Locate bolts in bag inside the machine.

VER SYSTEM ASSEMBLY

3. Lift VER system up and over lower air inlet, then align and slide into lower air inlet. VER system slides inside lower air inlet at the seam.



WARNING! Use proper lifting techniques or use a lifting aid.

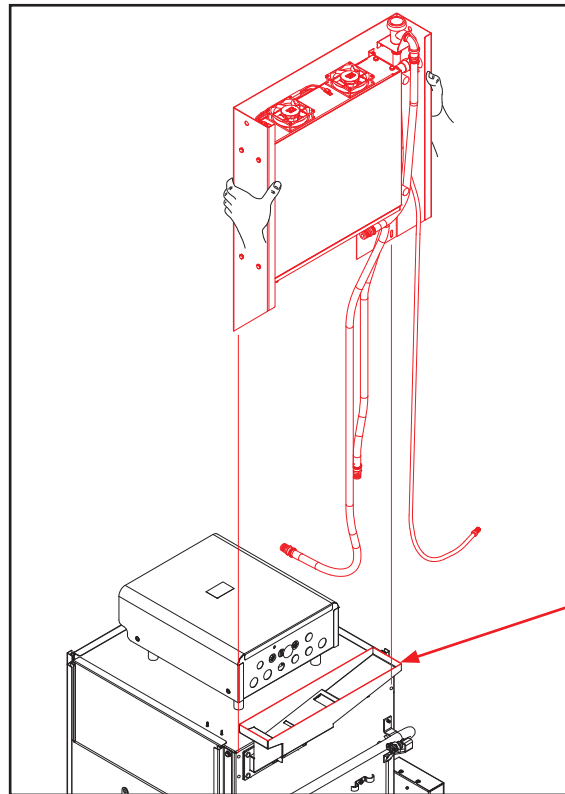

Lower Air Inlet Seam

4. Install four 1/4-20 bolts located in Step 1 with 7/16 wrench.

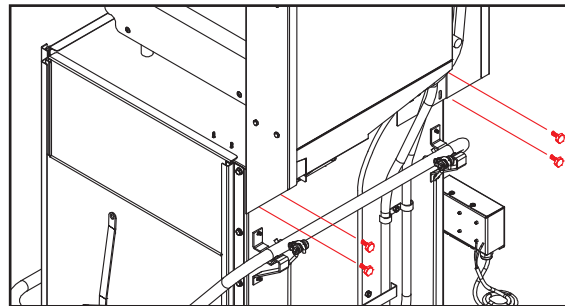

7/16 wrench used in this step.

Bolts located in Step 1 used in this step.

5. Use 9/16 wrench to connect gauge hose to side of tee on plumbing from booster.

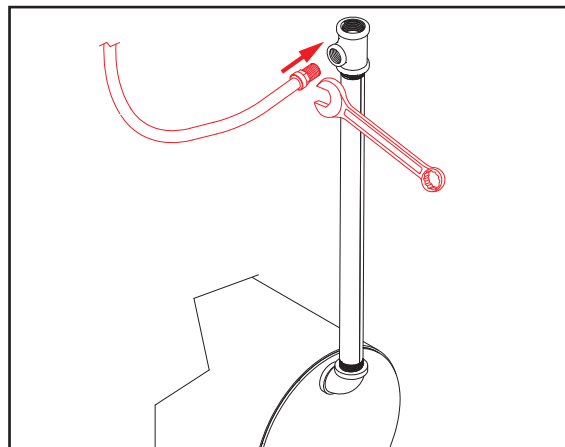

9/16 wrench used in this step.

Apply thread tape to threads of hose before connecting.

Hose is cut-to-length and will only reach intended connection point.

VER SYSTEM ASSEMBLY

6. Use adjustable wrench to connect long red hose to top of tee on plumbing from booster.

Adjustable wrench used in this step.

Apply thread tape to threads of hose before connecting.

Hose is cut-to-length and will only reach intended connection point.

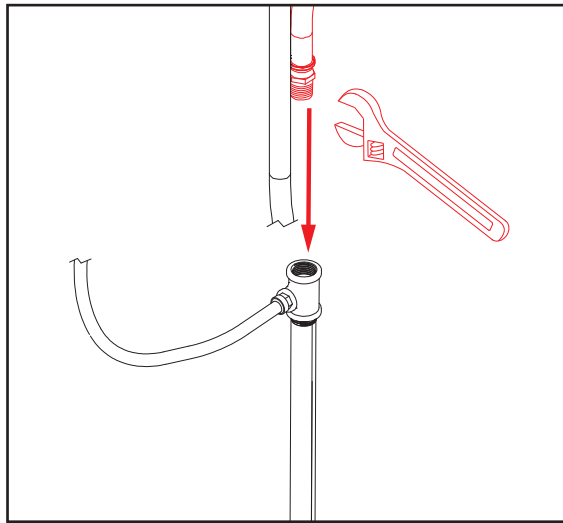

7. Use adjustable wrench to connect short red hose to rinse injector.

Adjustable wrench used in this step.

Apply thread tape to threads of hose before connecting.

Hose is cut-to-length and will only reach intended connection point.

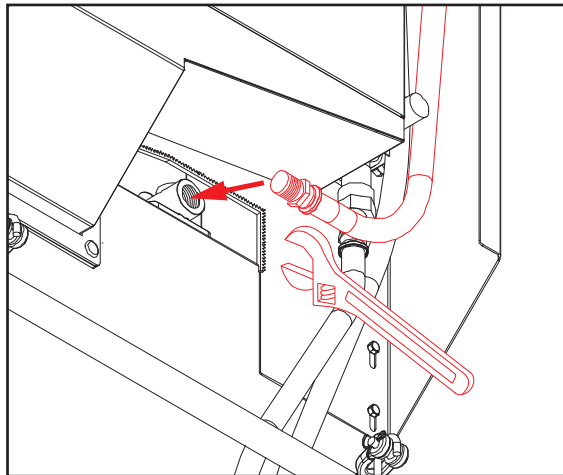

8. Use adjustable wrench to connect blue hose to coupling on plumbing going to booster.

Adjustable wrench used in this step.

Apply thread tape to threads of hose before connecting.

Hose is cut-to-length and will only reach intended connection point.

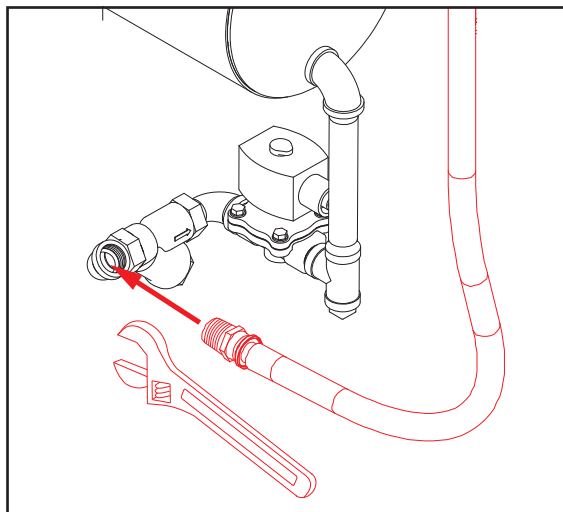

VER SYSTEM ASSEMBLY

9. Tidy hoses by sliding them under clamps.

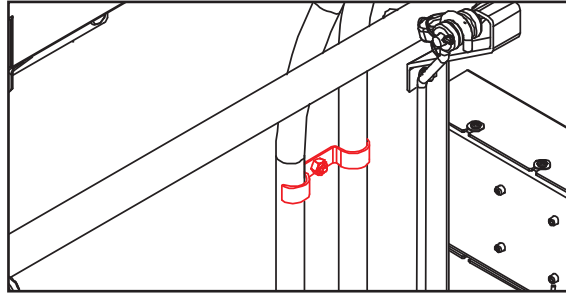

10. Locate wire connectors on fan wires at top of VER system (near fans) and connect BLK wire and WHT wire from machine control box (located in black cord routed from control box). Connect BLK fan wires to connector with BLK wire (-) and RED fan wires to connector with WHT wire (+).

BLK and WHT wires are shipped disconnected on end shown, but are already connected inside control box.



CAUTION! Fan wires must be connected to black wire and white wire before proceeding with machine installation!

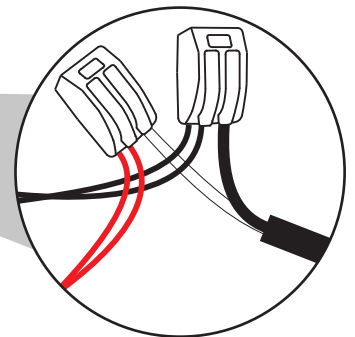
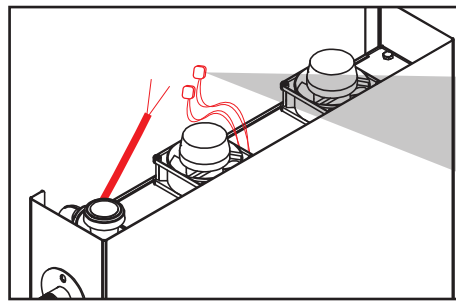

11. Tidy wires and lock them in place with p-clamp on top of VER system.

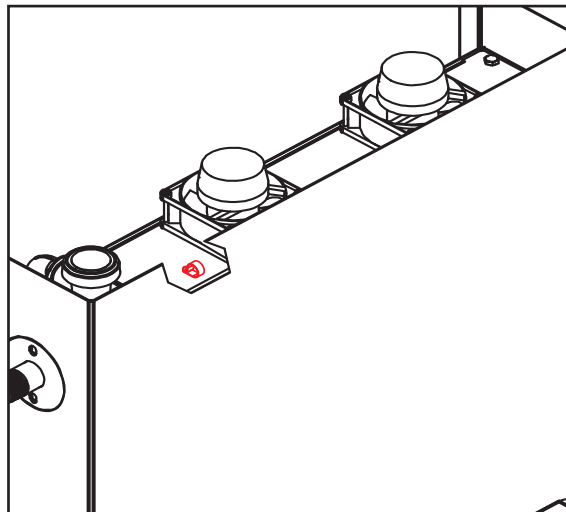

12. VER system is now assembled.

LEVELING The machine must be level in its operating location to prevent damage to the machine during operation and to ensure best results. The machine comes with four adjustable bullet feet, which can be turned using a pair of channel locks (or by hand if the machine can be raised safely). Ensure that the machine is level from side-to-side and front-to-back before making any connections.

PLUMBING Plumbing connections must comply with all applicable local, state, and national plumbing codes. The plumber is responsible for ensuring the incoming water line is thoroughly flushed before connecting it to any component of the machine. It is very important to remove all foreign debris from the water line that might potentially get trapped in the valves or cause an obstruction. Any valves that are fouled as a result of foreign matter left in the water line—and any expenses resulting from this fouling—are not the responsibility of the manufacturer.

Plumber MUST flush the incoming water line!

A water hardness test MUST be performed.

A water hardness test must be performed to determine if a water treatment system needs to be installed.

**WATER SUPPLY CONNECTION:
WATER HARDNESS GREATER THAN 3 GPG**

If water hardness tests at greater than 3 GPG, install the Scaltrol Water Treatment system (see the Plumbing Options page) into the water line before the machine's incoming water connection point. A water shut-off valve should be installed to allow access for service.

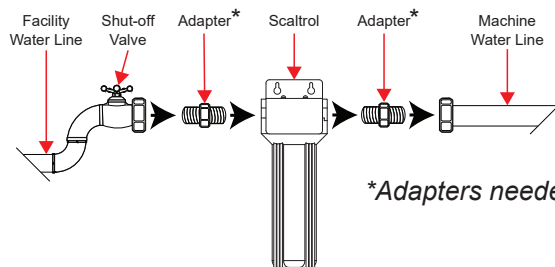

**Adapters needed will vary.*

**WATER SUPPLY CONNECTION:
WATER HARDNESS LOWER THAN 3 GPG**

If water hardness tests at lower than 3 GPG, install the water supply line directly to the machine's incoming water connection point. A water shut-off valve should be installed to allow access for service.

PRESSURE REGULATOR



The manufacturer recommends installation of a pressure regulating valve (PRV) in the incoming water line to ensure proper flowrate at all times and offers these devices as options (see the Plumbing Options page). The PRV comes standard on the TempStar VER but ships inside the machine. Click [here](#) for install instructions.

Do not confuse static pressure with flow pressure. Static pressure is the line pressure in a “no flow” condition (all valves and services are closed). Flow pressure is the pressure in the fill line when the fill valve is opened during the cycle.

SHOCK ABSORBER

The manufacturer also recommends installation of a shock absorber in the incoming water line and offers these devices as options (see the Plumbing Options page). This prevents line hammer/hydraulic shock—induced by the solenoid valve as it operates—from causing damage to the equipment.

CONNECTING THE DRAIN LINE

The machine's drain is a gravity-discharge drain. All piping from the 1 1/2” NPT connection on the wash tank must be pitched (1/4” per foot) to the floor or sink drain. All piping from the machine to the drain must be a minimum 1 1/2” NPT and must not be reduced. There must also be an air-gap between the machine drain line and the floor sink or drain. If a grease trap is required by code, it should have a flow capacity of 5 GPM.

EXHAUST FAN TIMER

Determine which exhaust fan timer is on the machine (located in the control box) and click the instructions icon below that timer to access programming instructions.

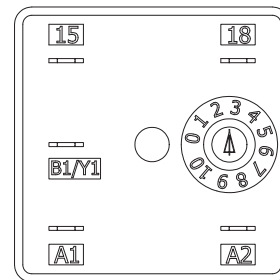
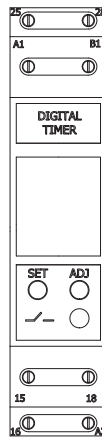

CHEMICAL CONNECTIONS

Chemical connections should be made by chemical supplier.

Using deionized water or other aggressive fluids will result in corrosion and failure of components and will void the warranty.



WARNING! Some of the chemicals used in dishwashing can cause chemical burns if they come in contact with skin. Wear protective gear when handling these chemicals. If any skin comes in contact with these chemicals, immediately follow the instructions provided with the chemicals for treatment.



Detergent
Connect detergent by removing bulkhead fitting on back of the machine and replacing it with appropriate dispensing equipment.

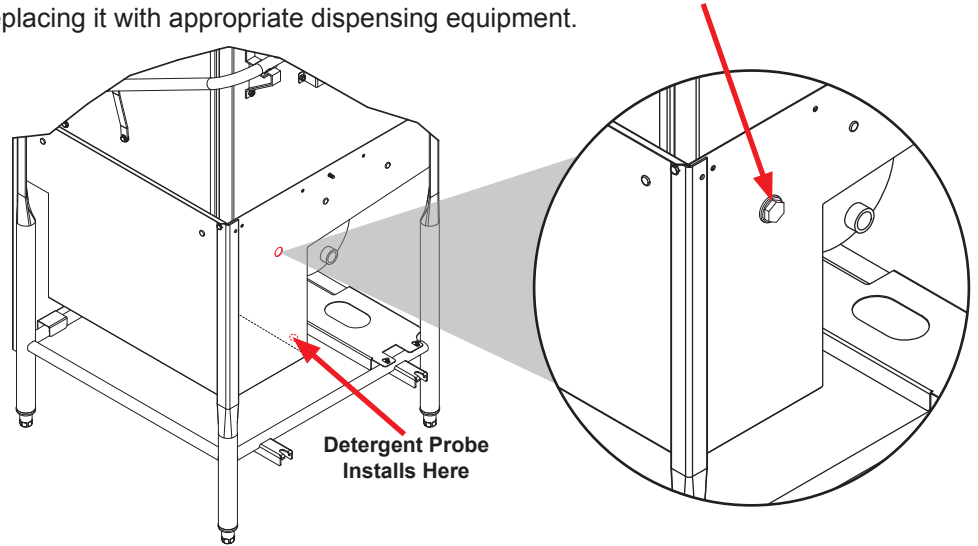

Rinse-aid
Connect rinse-aid by removing brass plug at base of rinse injector and replacing it with appropriate dispensing equipment. See Plumbing - VER page for a depiction of VER rinse injector.

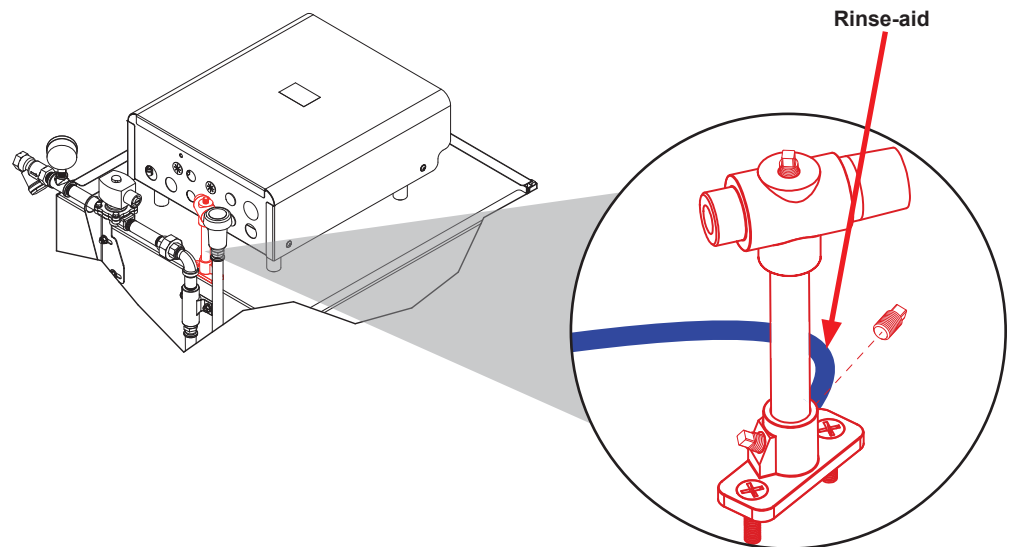

Dispenser Electrical Connections
Electrical connections for chemical dispensers are made on a fuse block inside control box. Click [here](#) for a depiction of fuse block and connection locations.

PLUMBING CHECK

Slowly turn on water supply to the machine after incoming fill line and drain line have been installed. Check for any leaks and repair as required. All leaks must be repaired before operating the machine.

ELECTRICAL POWER CONNECTIONS

Electrical and grounding conductors must comply with applicable portions of National Electric Code ANSI/NFPA 70 (latest edition) and/or other electrical codes.



Disconnect electrical power supplies and lockout/tagout in accordance with appropriate procedures and codes at the disconnect switch.

If necessary, see Heaters page for phase conversion kit.

Data plate is located on right side of the machine. Refer to data plate for machine operating requirements, machine voltage, total amperage, and serial number.

1. Open control box by using a phillips screwdriver to remove four screws on front cover of control box.
2. Install 3/4" conduit into pre-punched holes in back of control box.
3. Route power wires and connect to power block and grounding lug.
4. Install service wires (L3 for 3-Phase only) to appropriate terminals as they are marked on terminal block.

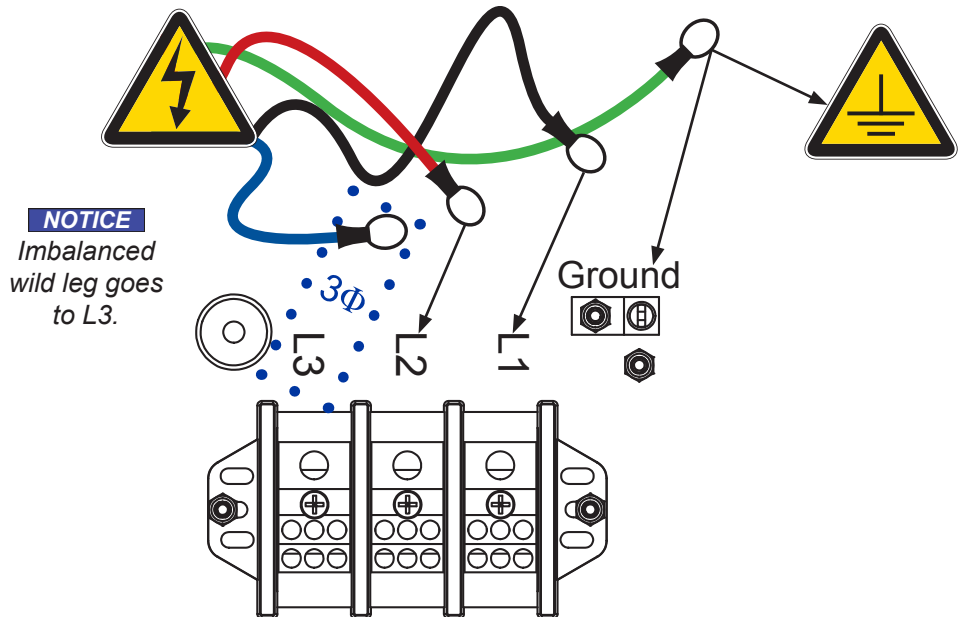

5. Install grounding wire into lug provided.
6. Tighten connections.

NOTICE "DE-OX" or similar anti-oxidation agent should be used on all power connections.



CAUTION! Improperly connecting external devices can cause damage to the machine and/or electrical infrastructure! Click [here](#) for a wiring guide.

MOTOR ROTATION

On 3-Phase machines only, correct pump motor rotation must be verified before the machine is operated. Failure to do so can result in damage to the machine and components.

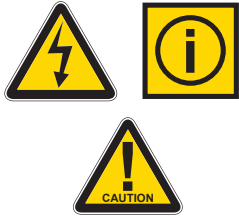

CAUTION! On 3-Phase machines only, correct pump motor rotation must be verified before operation!

1. Follow Filling the Wash Tub section.
2. Locate wash pump motor and identify arrow decal which shows correct motor rotation (if no decal is present, correct rotation is away from pump volute).

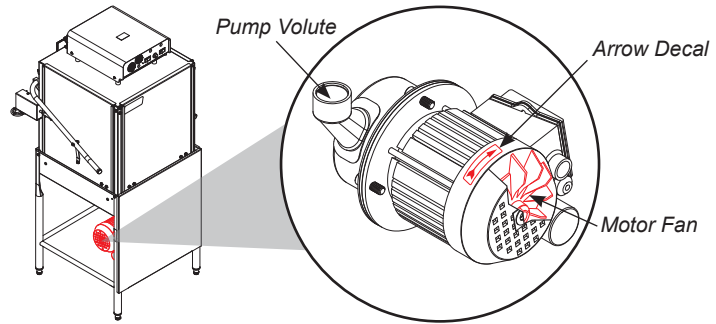

3. Flip mode switch to "MANUAL" and start the machine.
4. Observe rotation of motor fan and quickly stop the machine.
5. If rotation is incorrect, disconnect electrical power and reverse L1 and L2 connections at terminal block shown in section above.

VOLTAGE CHECK

Ensure power switch is in "OFF" position and apply power to the machine. Check incoming power at terminal block and ensure it corresponds with voltage listed on data plate. If not, contact a qualified service agency. Do not run the machine if voltage is too high or too low. Shut off service breaker and advise all proper personnel of the location of breaker and any problems. Replace control box cover and tighten-down screws.



SURROUNDING AREA

This is a commercial dishmachine and reaches temperatures that can exceed those generated by a residential machine. Surrounding countertops, cabinets, flooring material, and subflooring material must be designed and/or selected with these higher temperatures in mind.

NOTICE Any damage to surrounding area caused by heat/moisture to materials that are not recommended for higher temperatures will not be covered under warranty or by the manufacturer.

TEMPERATURE SETPOINTS

The temperature setpoints on the machine have been set at the factory. They should only be adjusted by an authorized service agent.

FALSE PANEL/ CORNER INSTALL

The manufacturer offers an optional False Panel Kit for corner installations. See the Kits page for kit part number. Click [here](#) for false panel/corner install instructions.



PREPARATION Before operating the machine, verify the following:

1. Tank is clean and free of debris.
2. Wash arms, rinse arms, sump strainer, and scrap screen are all installed correctly.
3. Standpipe is installed.

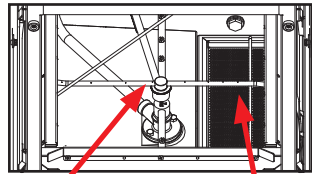

Wash & Rinse Arms, Scrap Screen

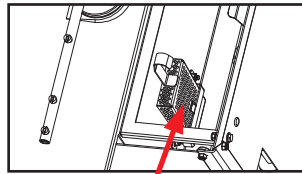

Sump Strainer

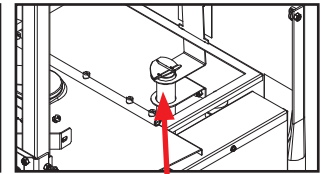

Standpipe

POWER UP To energize the machine, turn on power at service breaker. Voltage should have been previously verified. If not, verify voltage.

FILLING THE WASH TUB Ensure mode switch is in "AUTO" position, and place power switch into "ON" position. The machine will fill automatically and shut-off when appropriate level is reached (just below scrap screen). Wash tub must be completely filled before operating wash pump to prevent damage to components. Once wash tub is filled, the machine is ready for operation.

WARE PREPARATION Proper ware preparation will help ensure good results and fewer re-washes. If not prepared properly, ware might not come out clean and efficiency of the machine will be reduced. Putting unscrapped dishes into the machine affects its performance, so scraps should always be removed from ware before being loaded into a rack. Pre-rinsing and pre-soaking are good ideas, especially for silverware and casserole dishes.

Place cups and glasses upside-down in racks so they don't hold water during the cycle. The machine sanitizes as well as cleans. To do this, ware must be properly prepared before being placed in the machine.

DAILY MACHINE PREPARATION Refer to Preparation section and follow instructions there. Afterward, ensure chemicals are supplied to the machine. If not, contact chemical supplier.

WARM-UP CYCLES

For first operation of each day, it might be necessary to run the machine through three cycles to ensure all cold water is out of the system and to verify that the machine is operating correctly. To cycle the machine, ensure power is on and tub has filled to correct level. Lift and close door and cycle light will illuminate. The machine will start, run through cycle, and shut-off automatically. Repeat this two more times. The machine is now ready.

WASHING A RACK OF WARE

To wash a rack, open door completely (avoiding hot water that might drip) and slide rack into the machine.

Close door and the machine will start automatically. Once cycle is complete, open door and remove rack of clean ware. Replace with a rack of soiled ware and close door. Repeat this process.

OPERATIONAL INSPECTION

Based on use, scrap screen might become clogged with soil and debris as workday progresses. Operators should regularly inspect scrap screen to ensure it has not become clogged. If clogged, it will reduce washing capability of the machine. Instruct operators to clean-out scrap screen at regular intervals or as required by workload. Do NOT beat strainers to remove debris.

SHUTDOWN & CLEANING

1. Turn machine off by flipping power switch to "OFF."

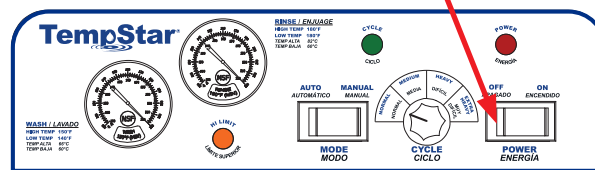

- 2. Open door and allow steam/heat to escape.
- 3. Remove standpipe and allow tub to drain.



WARNING! Wash tank water will be hot!

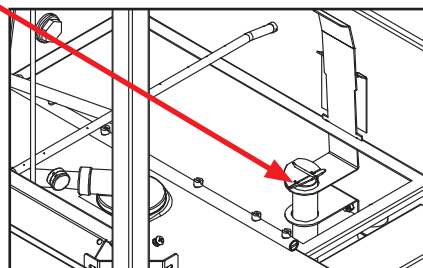

SHUTDOWN & CLEANING

4. Remove scrap screen and sump strainer.

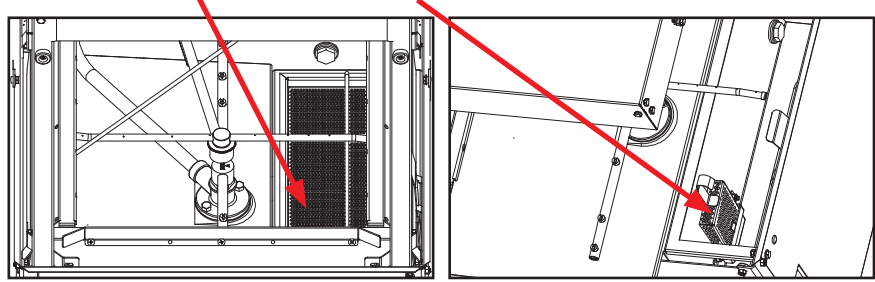

5. Use a hand-scraper to scrape foodsoil into a trash basket.

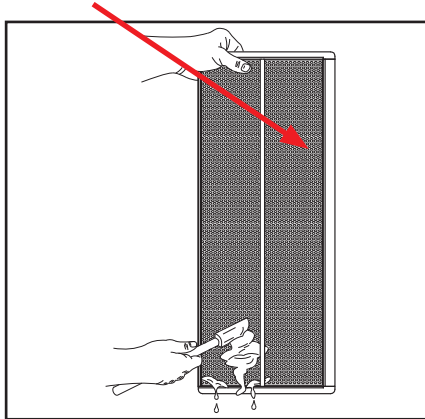

6. Rinse with pre-rinse hose and replace.

7. Remove all wash and rinse arms.

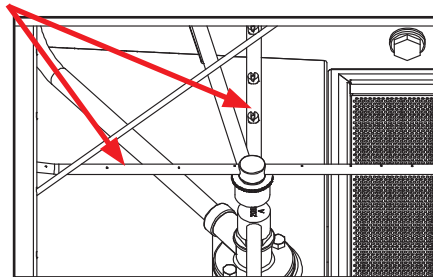

8. Remove end-caps from the arms.

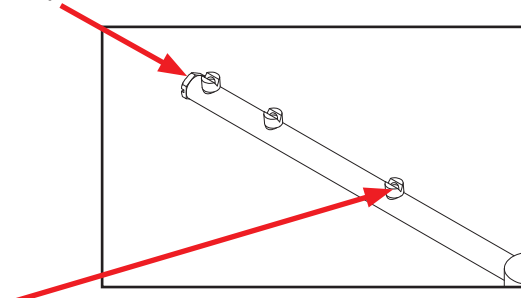

9. Clean nozzles with a brush.

10. Use a small wire or toothpick to remove remaining debris or lime deposits from nozzles.

11. Flush arms with water.

SHUTDOWN & CLEANING

12. Replace end-caps and ensure they are tight.

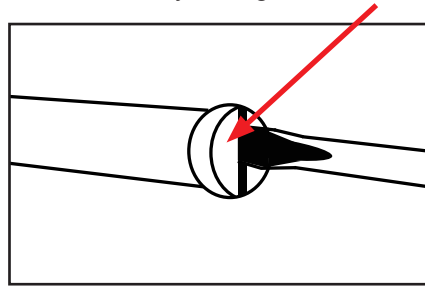

13. Spray or wipe out interior of the machine.

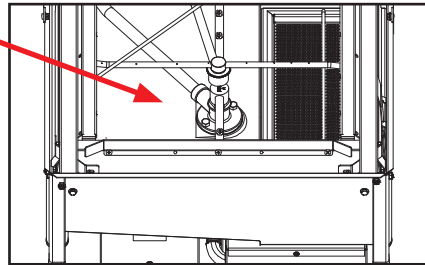

14. Replace wash and rinse arms.

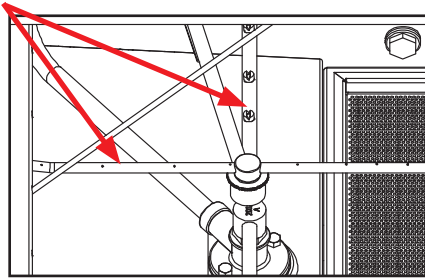

15. Ensure sump strainer and scrap screen are clean and securely in place.

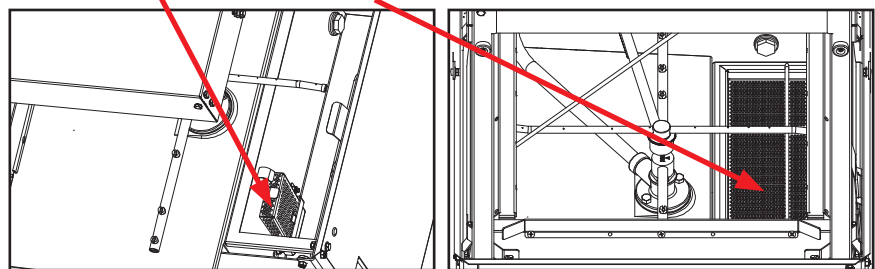

16. Use stainless steel polish to clean and protect outside of the machine.

VER COIL CLEANING

Coil on VER model must be inspected periodically. If the coil is greasy, dirty, or there is scale build-up, click [here](#) for cleaning instructions.



**DETERGENT
CONTROL**

Detergent usage and water hardness are two factors that contribute greatly to how efficiently the machine will operate. Using detergent in proper amounts can become a source of substantial savings. A qualified water treatment specialist can determine what is needed for maximum efficiency from the detergent.

*See Water Supply
Connection section for
more information
on water treatment.*

1. Hard water greatly affects performance of the machine, causing amount of detergent required for washing to increase. If the machine is installed in an area with hard water, the manufacturer recommends installation of water treatment equipment.
2. Deposited solids from hard water can cause spotting that will not be removed with a drying agent. Treated water will reduce this occurrence.
3. Treated water might not be suitable for use in other areas of operation and it might be necessary to install a water treatment system for the water going to the machine only. Discuss this option with a qualified water treatment specialist.
4. Machine operators should be properly trained on how much detergent is to be used per cycle. Meet with a water treatment specialist and detergent vendor to discuss a complete training program for operators.
5. The machine requires chemicals be provided for proper operation and sanitization and require installation of third-party chemical feeders to introduce these chemicals to the machine. Contact a chemical supplier with any questions.
6. Water temperature is an important factor in ensuring the machine functions properly. The machine's data plate details what the minimum temperatures must be for the incoming water supply, the wash tank, and the rinse tank. If minimum requirements are not met, there is a possibility that dishes will not be clean or sanitized.
7. Instruct machine operators to observe the required temperatures and to report when they fall below the minimum allowed. A loss of temperature can indicate a larger problem.



DELIMING To delime the machine, follow steps below. Tank capacities of the machine can be found on Operating Parameters page.

1. Remove rinse arms and place in sink with deliming solution.
2. Disconnect or turn off chemical feeder pumps.
3. Add deliming solution per chemical supplier's instructions.
4. Close door and turn the machine on in "MANUAL" mode.
5. Run the machine for length of time recommended by chemical supplier.
6. Flip mode switch to "AUTO" to shut the machine off.
7. Open door and step away for five minutes.
8. Inspect inside of the machine. If the machine is not delimed, run again.
9. When clean, drain and re-fill the machine.
10. Run two cycles in "AUTO" to remove residual deliming solution.
11. Drain and re-fill the machine.
12. Flush rinse arms with water and replace.

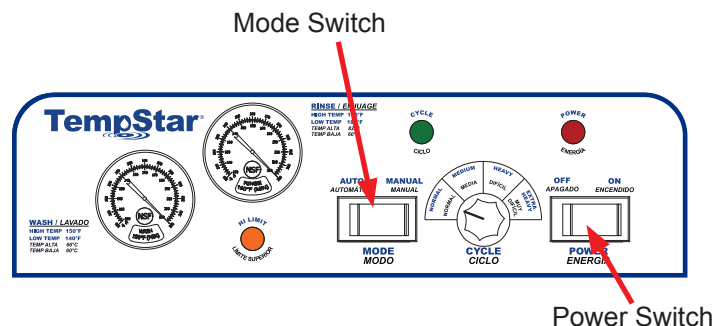

CAUTION! *The machine is not recommended for use with deionized water or other aggressive fluids. Using deionized water or other aggressive fluids will result in corrosion and failure of components and will void the warranty.*

PREVENTATIVE MAINTENANCE



The manufacturer highly recommends that any maintenance and repairs not specifically discussed in this manual be performed only by qualified service personnel.

WARNING! *Unqualified personnel performing maintenance on the machine may void the warranty, lead to larger problems, or cause harm to the operator.*



Following operating and cleaning instructions in this manual will result in the most efficient results from the machine. As a reminder, here are some steps to take to ensure the machine is being used the way it was designed to work:

CAUTION!
Do NOT beat strainers to remove debris!

1. Ensure water temperatures match those listed on machine data plate. A loss of temperature can indicate a larger problem.
2. Ensure all strainers are clean and securely in place before operating the machine. When cleaning out strainers, do NOT beat them on waste cans. Wipe out strainers with a rag and rinse with water if necessary. Use a toothpick to dislodge any stubborn debris.
3. Ensure all wash and rinse arms are secure in the machine before operating.
4. Ensure standpipe is in position before operating.
5. Remove as much soil from dishes by hand as possible before loading into racks.
6. Do not overfill racks.
7. Ensure glasses are placed upside-down in rack.
8. Ensure all chemicals being injected into the machine are at correct concentrations.
9. Clean the machine at end of every day/shift per Shutdown and Cleaning section.
10. Follow all safety procedures, whether listed in this manual or put forth by local, state, or national codes/regulations.

RESISTANCE-TO-TEMPERATURE VALUES

R (kΩ)	°F
11.58	69.8
10.37	75.2
9.30	80.6
7.78	89.6
3.05	140.0
2.54	150.8
2.18	159.8
1.58	179.6
1.45	185.0
1.33	190.4
1.16	199.4
0.96	212.0



WARNING! Inspection, testing, and repair of electrical equipment should only be performed by a qualified service technician. Many tests require the machine have power to it and live electrical components be exposed. USE EXTREME CAUTION WHEN TESTING THE MACHINE.

OBSERVATION	POSSIBLE CAUSE	REMEDY
Machine will not fill after door is closed. Power "ON" light is illuminated.	<ol style="list-style-type: none"> 1. Faulty rinse solenoid valve. 2. Faulty door switch. 3. Fouled/faulty high-level probe. 	<ol style="list-style-type: none"> 1. Repair or replace valve as required. 2. Verify wiring of switch; if correct, replace switch. 3. Clean probe if fouled. If clean and still not working, replace.
Machine will not fill after door is closed. Power "ON" light is NOT illuminated.	<ol style="list-style-type: none"> 1. Service breaker tripped. 2. Machine not connected to power source. 3. Faulty power source. 	<ol style="list-style-type: none"> 1. Reset. If breaker trips again, contact an electrician to verify amp draw of the machine. 2. Verify the machine has been properly connected to power source. 3. Verify wiring of switch; if correct, replace switch.
Machine will not run after door is closed. Power "ON" light is illuminated and the machine is filling.	<ol style="list-style-type: none"> 1. Timer is faulty. 2. Wash motor faulty/damaged. 3. Wash motor contactor faulty. 	<ol style="list-style-type: none"> 1. Verify timer is receiving power. If so, replace timer assembly. 2. Verify wash motor is getting power. If so, replace motor. 3. Check for continuity; if contacts are open, replace contactor.
Machine runs continuously in the wash cycle.	<ol style="list-style-type: none"> 1. Machine is in Delime mode. 2. Timer motor is faulty. 3. Cam timer jammed by obstruction. 	<ol style="list-style-type: none"> 1. Flip mode switch to "AUTO." 2. Verify timer is rotating. If not, verify motor is receiving power. If so, replace motor and/or timer assembly. 3. Remove obstruction.
Wash or rinse heater does not work.	<ol style="list-style-type: none"> 1. Faulty heater element. 2. Faulty heater contactor. 3. Misadjusted/faulty thermostat(s). 	<ol style="list-style-type: none"> 1. Check element for continuity; if open, replace heater. 2. Replace contactor. 3. Verify operation and setting of thermostats, replace if necessary.
Machine fills slowly and/or rinse is weak.	<ol style="list-style-type: none"> 1. Clogged or obstructed rinse arms. 2. Low incoming water pressure. 3. Y-strainer is clogged. 	<ol style="list-style-type: none"> 1. Remove and clean rinse arms. 2. Adjust water pressure regulator to ensure there is 10 ± 2 PSI flow. 3. Clean out Y-strainer.
Rinse water not reaching required temperature.	<ol style="list-style-type: none"> 1. Faulty rinse heater. 2. Mis-adjusted/faulty thermostat(s). 3. Rinse thermometer is defective. 	<ol style="list-style-type: none"> 1. Check element for continuity; if open, replace heater. 2. Verify operation and setting of thermostats, replace if necessary. 3. Replace thermometer.



WARNING! Inspection, testing, and repair of electrical equipment should only be performed by a qualified service technician. Many tests require the machine have power to it and live electrical components be exposed. USE EXTREME CAUTION WHEN TESTING THE MACHINE.

OBSERVATION	POSSIBLE CAUSE	REMEDY
Machine doesn't drain when power switch is flipped to "OFF."	<ol style="list-style-type: none"> 1. Drain clogged. 2. Standpipe not removed before draining. 	<ol style="list-style-type: none"> 1. Remove obstruction. 2. Remove standpipe and run drain cycle again.
Incorrect water pressure displayed during Fill or Rinse modes.	<ol style="list-style-type: none"> 1. Water turned off. 	<ol style="list-style-type: none"> 1. Turn water on.
Wash water is not reaching required temperature.	<ol style="list-style-type: none"> 1. Faulty wash heater. 2. Misadjusted/faulty thermostat(s). 3. Wash thermometer is defective. 	<ol style="list-style-type: none"> 1. Check element for continuity; if open, replace heater. 2. Verify operation and setting of thermostats, replace if necessary. 3. Replace thermometer.
Door will not close completely.	<ol style="list-style-type: none"> 1. Improper spring tension. 2. Obstruction in door channel. 3. Door panels are not square with frame. 	<ol style="list-style-type: none"> 1. Adjust spring tension as required by loosening (not removing) spring bolt nuts and adjusting tension. Tighten nuts back when done. 2. Remove obstruction. 3. Adjust frame to accommodate the door panels.
Water leaks at wash pump.	<ol style="list-style-type: none"> 1. Wash pump seal defective. 2. Petcock or pump drain (if equipped) not shut/tight. 3. Loose hoses (hose clamps) on the wash pump. 	<ol style="list-style-type: none"> 1. Replace seal. 2. Close or tighten. 3. Tighten hose clamps.
Will not rinse during autcycle.	<ol style="list-style-type: none"> 1. Defective rinse solenoid. 2. Faulty timer. 3. No water to the machine. 	<ol style="list-style-type: none"> 1. Repair or replace rinse solenoid as required. 2. Replace timer. 3. Verify there is water at 10 ± 2 PSI connected to the machine.
Dishes are not coming clean.	<ol style="list-style-type: none"> 1. Machine temperatures are not up to minimum requirements. 2. No detergent/too much detergent. 	<ol style="list-style-type: none"> 1. Verify incoming water, rinse water, and wash water match required temperatures as listed on machine data plate. 2. Adjust detergent concentration as required for amount of water held by the machine.

NOTICE

Machines before 21D393474 have a different control box. Click [here](#) to open earlier manual.

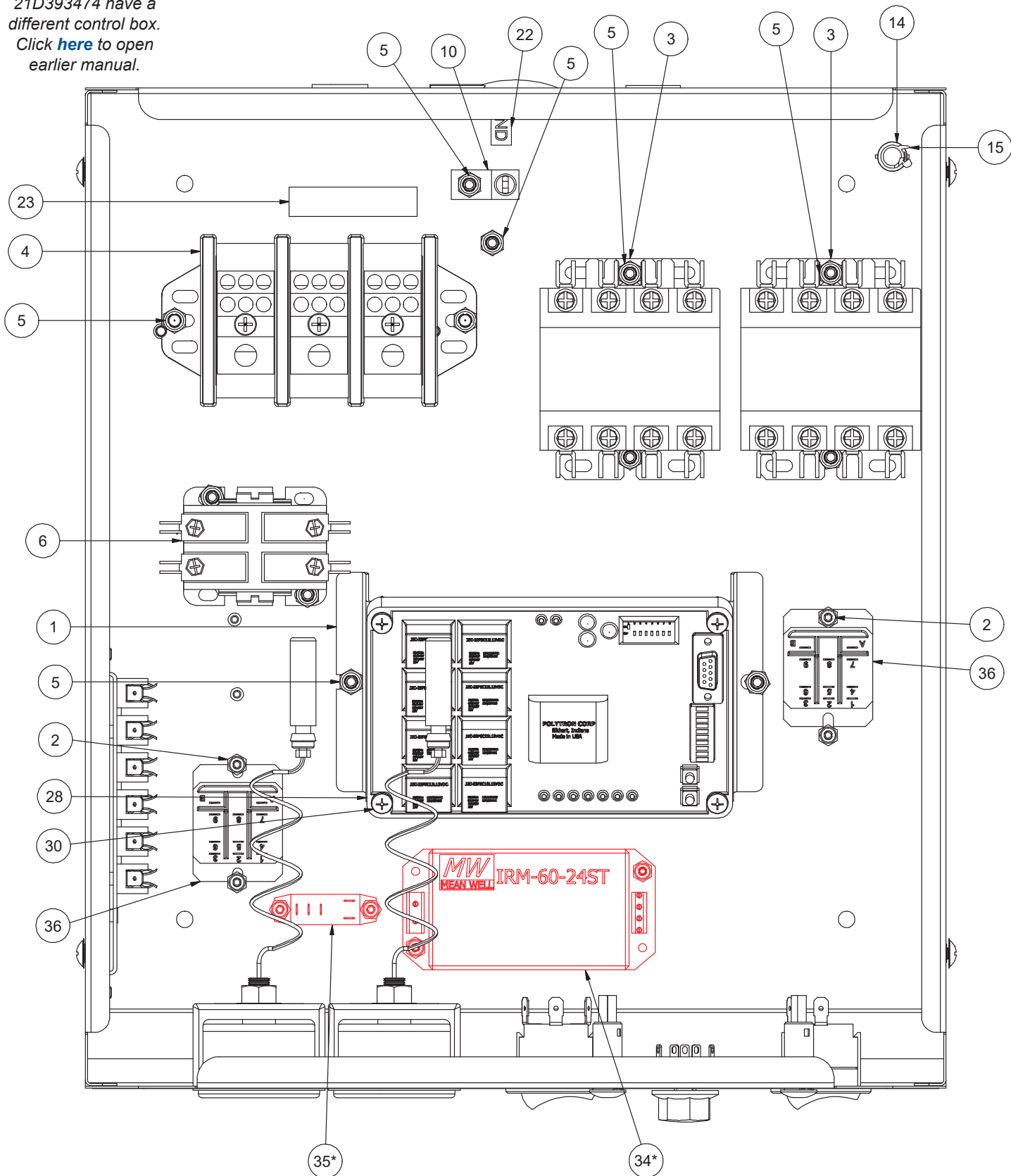

*Power supply and relay used only on machines with door interlock and VER machines with DC fans.

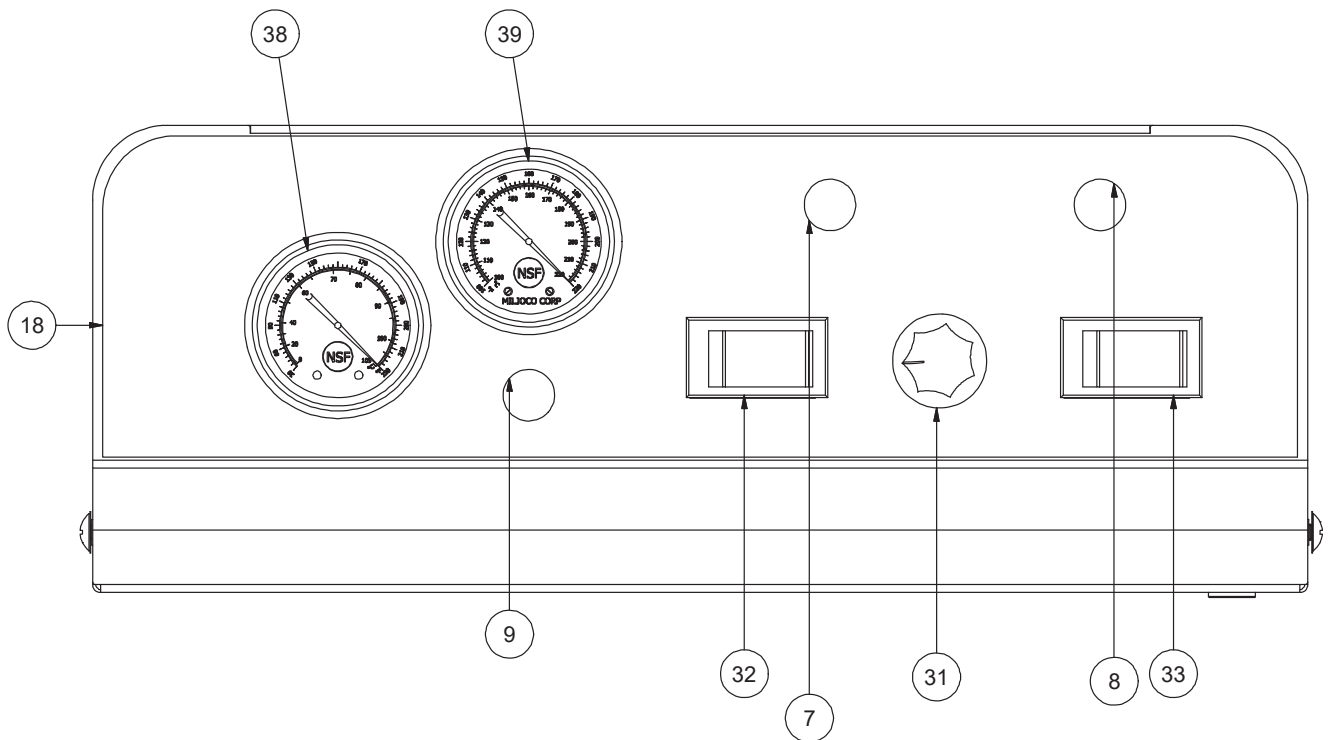
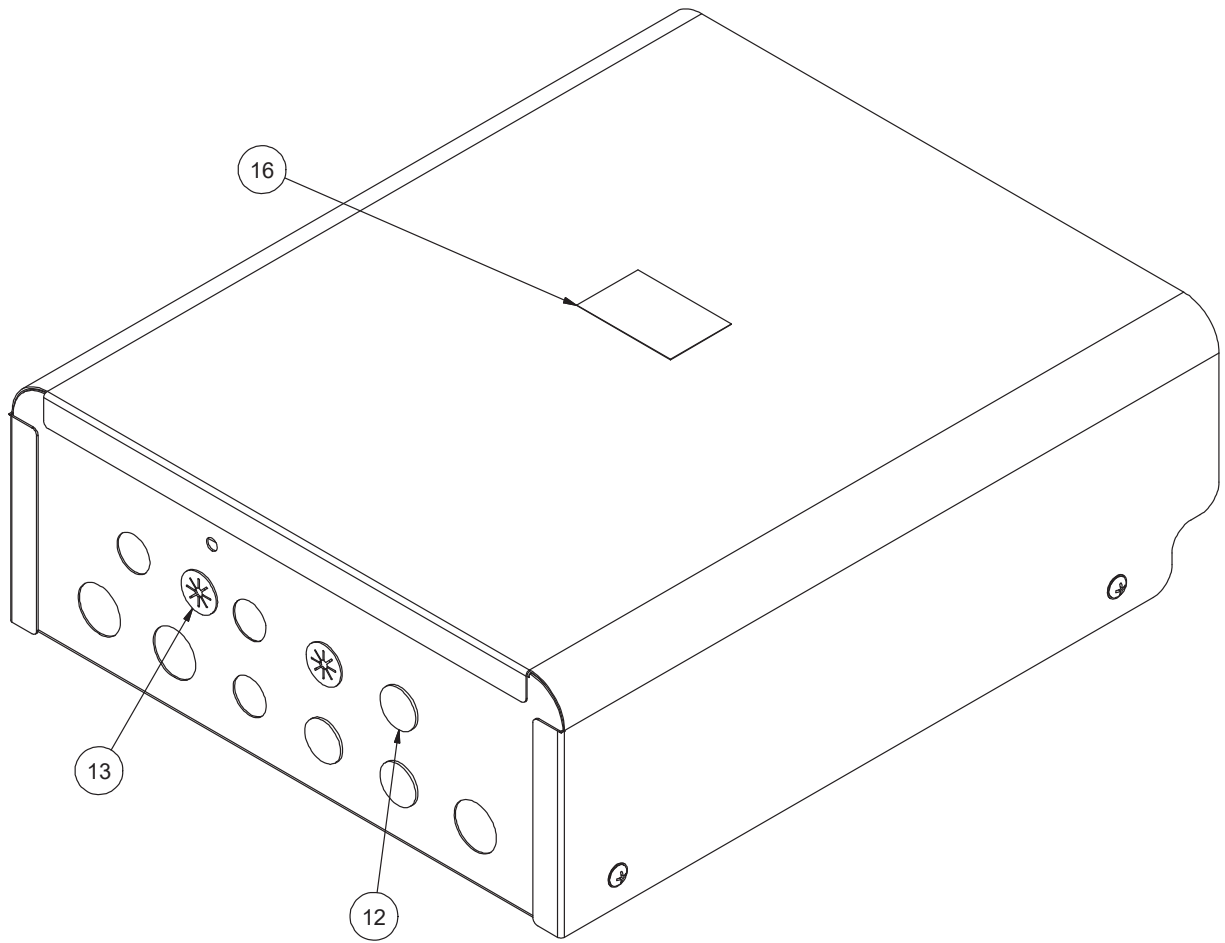

Fuses

208/230 V

or

460 V

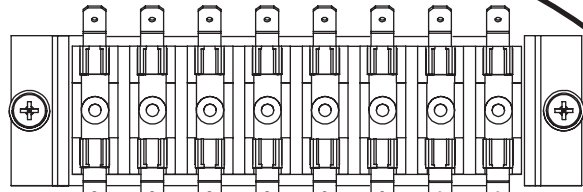
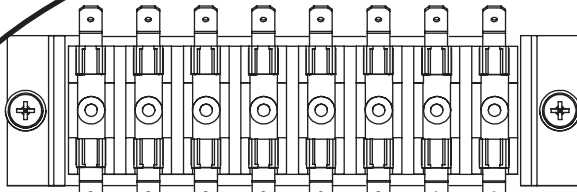

WARNING: DISCONNECT POWER TO MACHINE BEFORE SERVICING

EXHAUST FAN CONTROL	CONSTANT VOLTAGE CONNECTION	RINSE-AID DISPENSER CONNECTION	DETERGENT DISPENSER CONNECTION
MAXIMUM LOAD 1 AMP, 240/120 VAC	LIVE WHEN MACHINE POWER SWITCH IS ON	LIVE WHEN RINSE VALVE IS OPEN	LIVE WHEN WASH PUMP MOTOR IS ON
INPUT L1 (EXTERNAL)	OUTPUT TO EXT. RELAY	FUSE: 3 AMP SLOW-ACTING L1 OUT	FUSE: 3 AMP SLOW-ACTING L1 OUT

WARNING: DISCONNECT POWER TO MACHINE BEFORE SERVICING

EXHAUST FAN CONTROL	CONSTANT VOLTAGE CONNECTION	RINSE-AID DISPENSER CONNECTION	DETERGENT DISPENSER CONNECTION
MAXIMUM LOAD 1 AMP, 240/120 VAC	LIVE WHEN MACHINE POWER SWITCH IS ON	LIVE WHEN RINSE VALVE IS OPEN	LIVE WHEN WASH PUMP MOTOR IS ON
INPUT L1 (EXTERNAL)	OUTPUT TO EXT. RELAY	FUSE: 200 mA SLOW-ACTING L1 OUT	FUSE: 200 mA SLOW-ACTING L1 OUT

Fuse, 1 A, Fast-acting
05999-004-47-87
Littelfuse P/N - 0312001.HXP
Qty - 2 (2 per output)

Fuse, 3 A, Slow-acting
05999-004-44-34
Littelfuse P/N - 0313003.HXP
Qty - 6 (2 per output)

Fuse, 1 A, Fast-acting
05999-004-47-87
Littelfuse P/N - 0312001.HXP
Qty - 2 (2 per output)

Fuse, 200 mA, Slow-acting
05999-004-44-33
Littelfuse P/N - 0313.200HXP
Qty - 6 (2 per output)

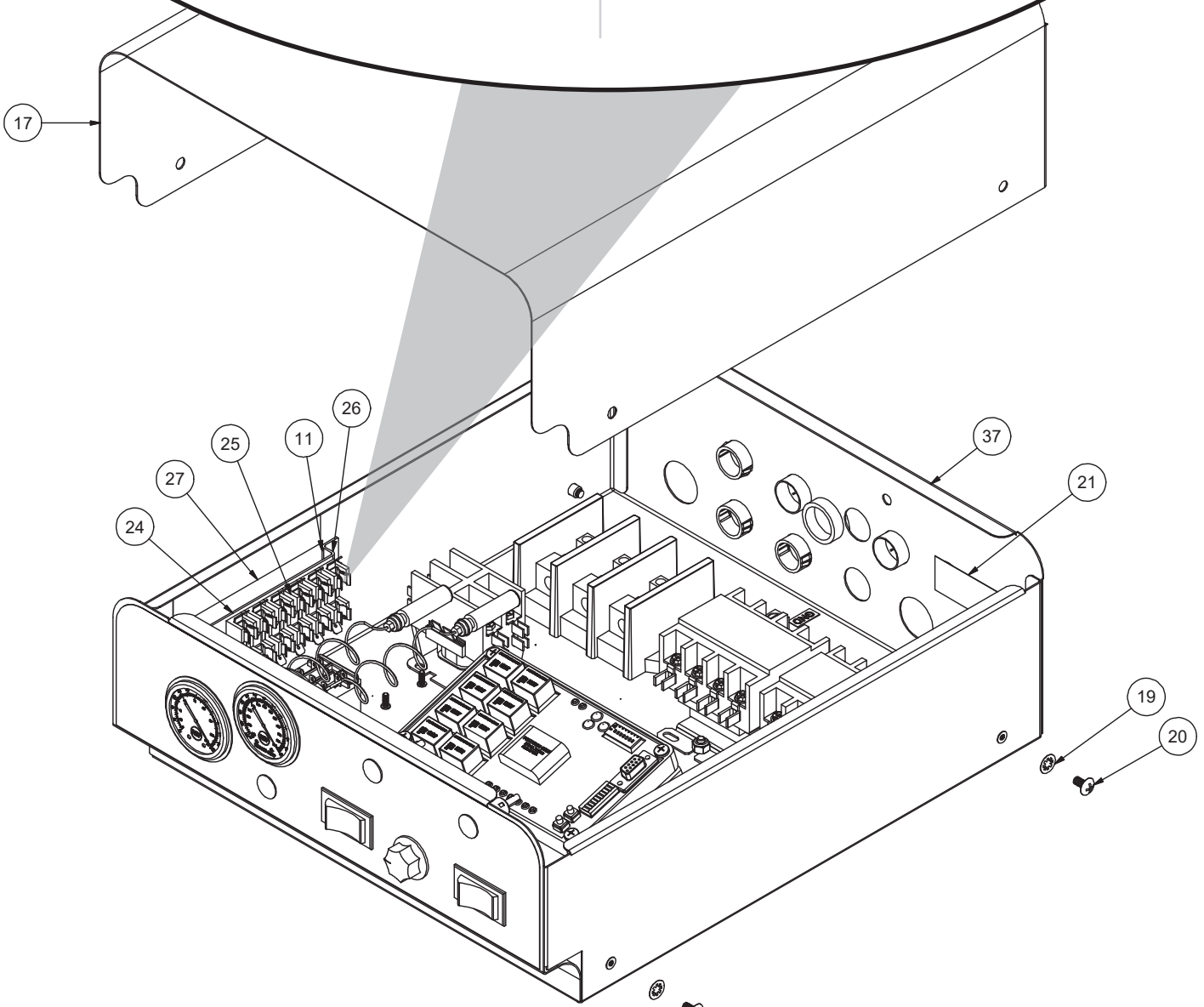

ITEM	QTY	DESCRIPTION	PART NUMBER
1	1	Timer Bracket	05700-003-02-08
2	8	Locknut, 6-32	05310-373-03-00
3	2	Contactora, 4-Pole	05945-004-43-74
4	1	Terminal Block	05940-011-48-27
5	14	Locknut, 10-24	05310-373-01-00
6	1	Contactora, Wash Motor	05945-002-74-20
7	1	Light, Green	05945-111-44-43
8	1	Light, Red	05945-111-44-45
9	1	Light, Yellow	05945-111-44-44
10	1	Ground Lug	05940-200-76-00
11	4	Tricnut, 6-32	05340-118-04-00
12	3	Plug, 1/2"	05975-011-47-81
13	2	Grommet, 7/8" Split	05975-200-40-00
14	1	Bushing Snap	05975-210-05-00
15	1	Clamp, Hose 1/4" - 1/3"	05975-002-61-43
16	1	Decal, Warning-Disconnect Power	09905-004-08-16
17	1	Cover, Top Mount Control Box	05700-002-23-03
18	1	Decal, Control Box	09905-003-97-36
19	4	Lockwasher, Int. Tooth #10	05311-273-03-00
20	4	Screw, 10-32 x 3/8" Phillips Truss Head	05306-004-42-04
21	1	Decal, Copper Conductors	09905-011-47-35
22	1	Decal, Ground	09905-011-86-86
23	1	Decal, L1, L2	09905-101-12-66
24	1	Bracket, Fuse Strip	05700-002-42-03
25	1	Fuse Holder, 6-pole	05920-002-42-13
26	4	Screw, 6-32 x 3/8" with Tooth Washer	05305-002-25-91
27	1	Decal, Dispenser Connection	09905-003-34-09
	1	Decal, Dispenser Connection (460 V)	09905-004-43-81
28	1	Timer, Universal	05945-003-75-23
29	4	Locknut, 10-32	05340-118-05-00
30	4	Screw 10-32 x 1"	05340-118-05-00

ITEM	QTY	DESCRIPTION	PART NUMBER
31	1	Switch, Rotary Selector	05930-003-97-61
32	1	Switch, Operation	05930-301-53-00
33	1	Switch, Power	05930-011-49-55
34*	1	Power Supply, In 100-240 V DC, 1.8 A, Out 24 V, 2.5 A*	05950-004-81-79*
35*	1	Relay, 10 A, 220 V*	05945-004-84-93*
36	2	Relay, 240 V	05945-002-47-74
37	1	Control Box Weldment	05700-003-30-14
38	1	Temperature Gauge, 96"	06685-004-31-46
39	1	Temperature Gauge, 48"	06685-004-31-47
40	1	Transformer, 460 V Machine Only (Not Shown)	05950-111-65-93
41	1	Fuse Holder, Single, 460 V Machine Only (Not Shown)	05920-011-72-89
42	1	Fuse, 1 A, Bussman P/N FNQ-R-1, 460 V Machine Only (Not Shown)	05920-002-67-23
43	1	Pump Contactor, 460 V Machine Only (Not Shown)	05945-002-65-00
44	1	Overload, 4NK0AKY 1.7-2.6, 460 V Machine Only (Not Shown)	05945-002-65-02

*Power supply and relay used only on machines with door interlock and VER machines with DC fans.

NOTICE

Machines before
21D393474 have a
different control box.
Click [here](#) to open
earlier manual.

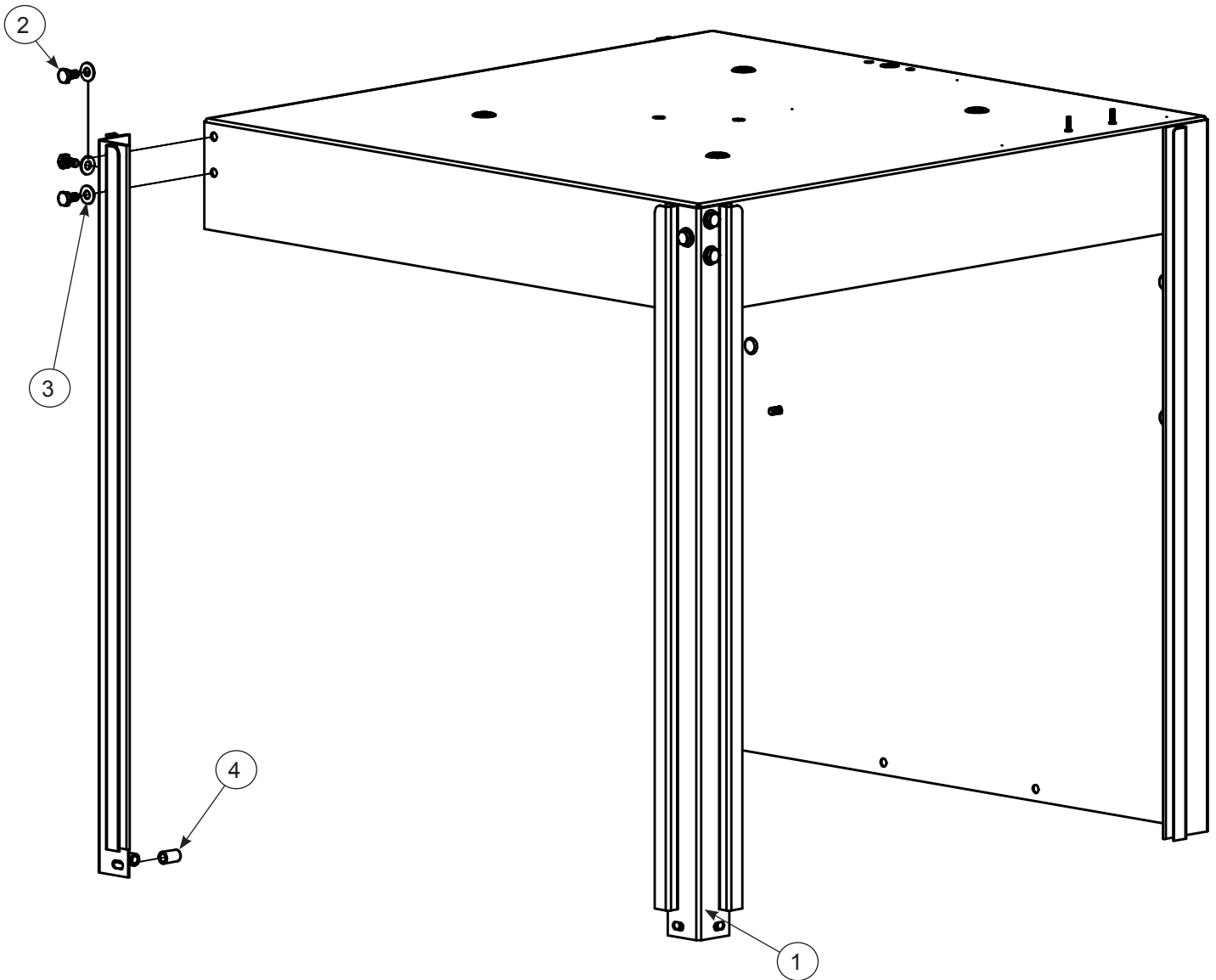

ITEM	QTY	DESCRIPTION	PART NUMBER
1	2	Hood Support	05700-002-78-99
2	6	Bolt, 1/4-20 x 1/2"	05305-274-21-00
3	6	Washer, Flat, SS, 1/4-20	05311-174-01-00
4	4	Spacer, Sleeve Hood	05700-003-55-15
5	6	Locknut, 1/4-20 with Nylon Insert (Not Shown)	05310-374-01-00

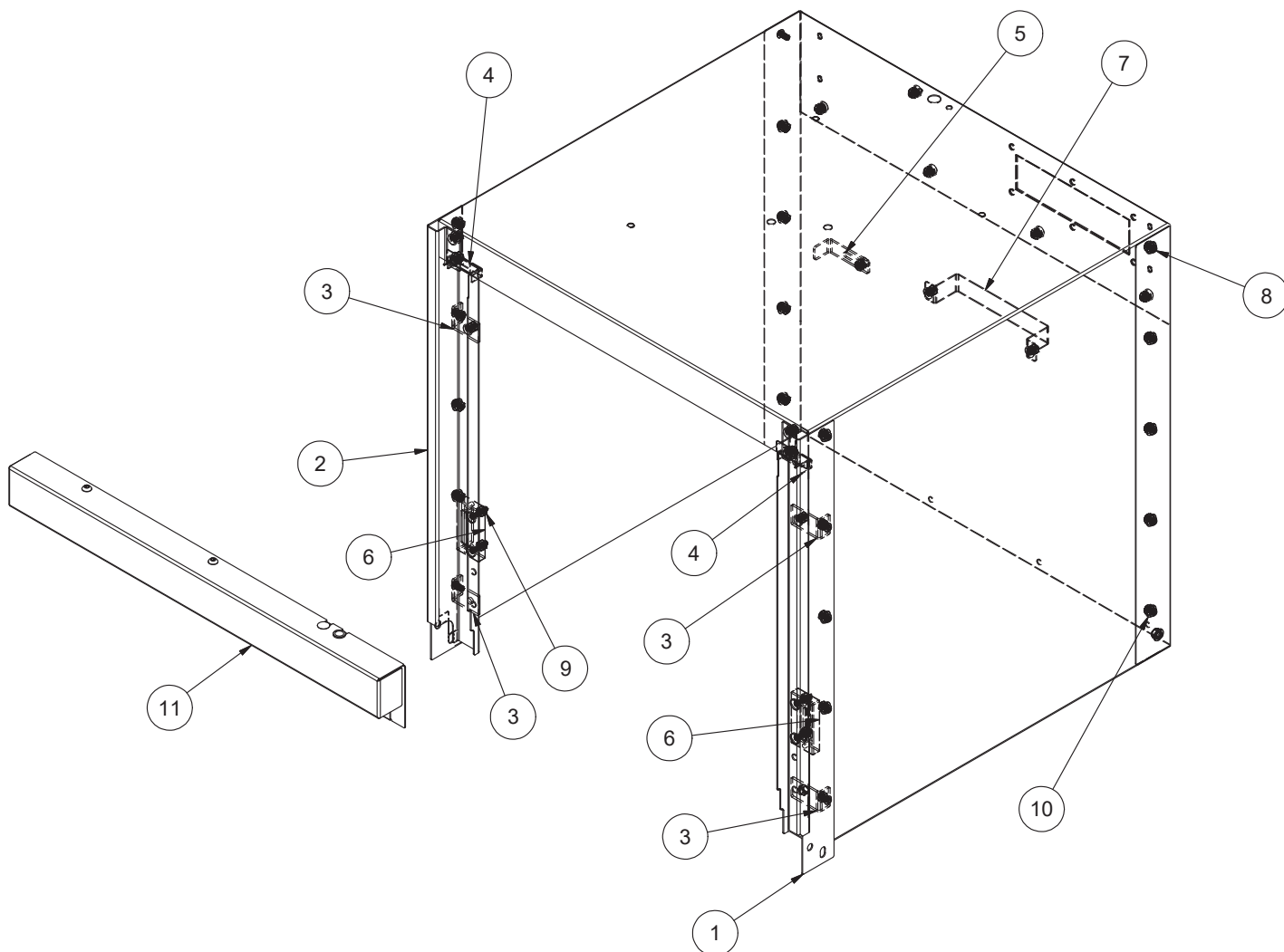

ITEM	QTY	DESCRIPTION	PART NUMBER
1	1	Upright, Right	05700-004-81-53
2	1	Upright, Left	05700-004-81-54
3	4	Bracket, Upright Upper	05700-004-76-36
4	2	Cap, Upright	05700-004-79-65
5	1	Bracket, Manifold Position	05700-011-34-63
6	2	Guide Block, Stop	09330-004-77-73
7	1	Bracket, Conduit	EL-104106
8	20	Screw, 1/4-20 x 1/2" Button Head Hex	05305-004-62-33
9	40	Locknut, 1/4-20 Hex with Nylon Insert	05310-374-01-00
10	20	Washer, 1/4-20	05311-174-01-00
11	1	Upper Dress with Door Interlock	05700-005-06-44
		Upper Dress without Door Interlock	05700-005-06-43

ITEM	QTY	DESCRIPTION	PART NUMBER
1	1	Cantilever Arm	05700-031-50-67
2	2	Spring Pin, 1/4" x 1 1/8"	05315-407-06-00
3	2	Yoke Assembly	05700-000-75-77
3a	1	Cotter Pin	05315-207-01-00
3b	1	Yoke	05700-000-75-78
3c	1	Clevis Pin, 5/16" x 1 3/8"	05315-700-01-00
3d	2	Nylon Washer	05311-369-03-00
3e	1	Bushing	03120-100-03-00
4	2	Rod, Spring	05700-003-67-39
5	2	Spring	05340-109-02-00
6	2	Bolt, Cantilever Hanger Eye 3/8-16	05306-956-05-00
7	2	Washer, 3/8" ID x 7/8" OD	05311-176-02-00
8	4	Nut, 3/8-16 S/S Hex	05310-276-01-00
9	2	Connector, Cantilever Arm	05700-011-90-99
10	2	Screw, 1/4-20 x 1 1/2"	05305-274-23-00
11	4	Washer, 1/4"	05311-174-01-00
12	4	Locknut, 1/4-20 Hex with Nylon Insert Low Profile	05310-374-02-00
13	2	Sleeve, Cantilever Arm	05700-000-85-69
14	2	Plug, Cantilever Arm	05340-011-35-00
15	1	Magnet, Reed Switch	05930-111-51-68
16	2	Locknut, 8-32 Hex with Nylon Insert	05310-272-02-00
17	1	Door, Right Side (Complete Assembly)	05700-004-07-47
	1	Door, Right Side (Weldment with Studs)	05700-002-29-85
18	6	Guide, Door	05700-111-33-59
19	2	Screw, 1/4-20 x 1/2"	05305-274-02-00
20	2	Spacer, PB Bolt	05700-000-29-40
21	4	Locknut, 1/4-20 Hex with Nylon Insert (Not Shown)	05310-374-01-00
22	2	Door Connector Bracket	05700-021-33-39
23	1	Door, Front with Decal (Complete Assembly)	05700-002-30-89
	1	Door Only, Front	05700-002-67-71

ITEM	QTY	DESCRIPTION	PART NUMBER
24	1	Door, Left Side (Complete Assembly)	05700-002-30-87
	1	Door, Left Side (VER, Complete Assembly)	05700-004-24-32
	1	Door Only, Left Side	05700-002-29-86
	1	Door Only, Left Side (VER)	05700-004-24-34
25	1	Door Connecting Plate (Not Shown)	05700-002-20-78
26	2	Bracket, Cantilever Arm Support	09515-003-15-64
27	1	Wear Button, 1/2" Dia. UHMW (Not Shown)	05700-011-88-01
28	1	Door Interlock Bracket (Not Shown)	05700-004-23-17
29	1	Cover, Door Magnet	05700-004-07-39
30	1	Switch, Door/Cycle	05930-003-05-84

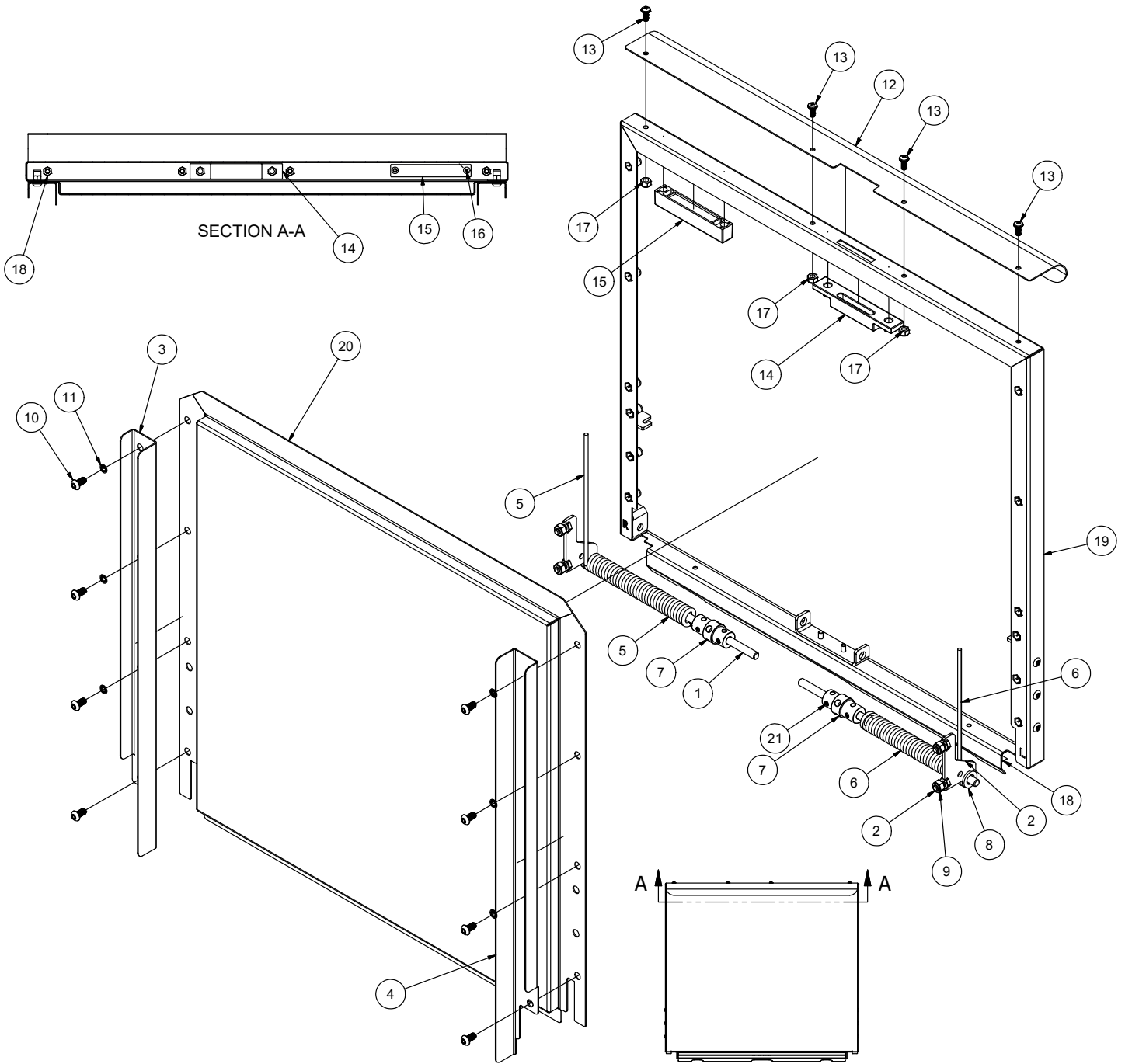

ITEM	QTY	DESCRIPTION	PART NUMBER
1	1	Bracket, Door, Right	05700-004-74-35
2	1	Bracket, Door, Left	05700-004-74-36
3	1	Guide, Rack, Right	05700-004-72-81
4	1	Guide, Rack, Left	05700-004-72-82
5	1	Spring, Door Torsion, Right	05340-004-74-71
6	1	Spring, Door Torsion, Left	05340-004-77-89
7	2	Yoke, Spring Rod	09515-004-74-76
8	2	Washer, Nylon	05311-369-03-00
9	4	Locknut, 1/4-20 Hex with Nylon Insert	05310-374-01-00
10	9	Screw, 1/4-20 x 1/2" Button Head Hex	05305-004-62-33
11	7	Washer, Lock 1/4"	05311-004-23-67
12	1	Door Handle	05700-005-05-48
13	4	Screw, 10-32 x 1/2" Pan with Washer	05305-002-32-37
14	1	Latch Receiver	09515-005-05-30
15	1	Magnet, 3/8" x 2 1/2"	05930-111-51-68
16	2	Screw, 8-32 x 1/4" Pan	05305-172-09-00
17	6	Locknut, 10-32 with Nylon Insert	05310-373-02-00
18	1	Bracket, Splash Shield	05700-005-05-57
19	1	Panel, Door Outer	05700-005-05-58
20	1	Panel, Door Inner	05700-005-05-59
21	4	Set Screw, 8-32 x 5/8"	05305-004-77-87

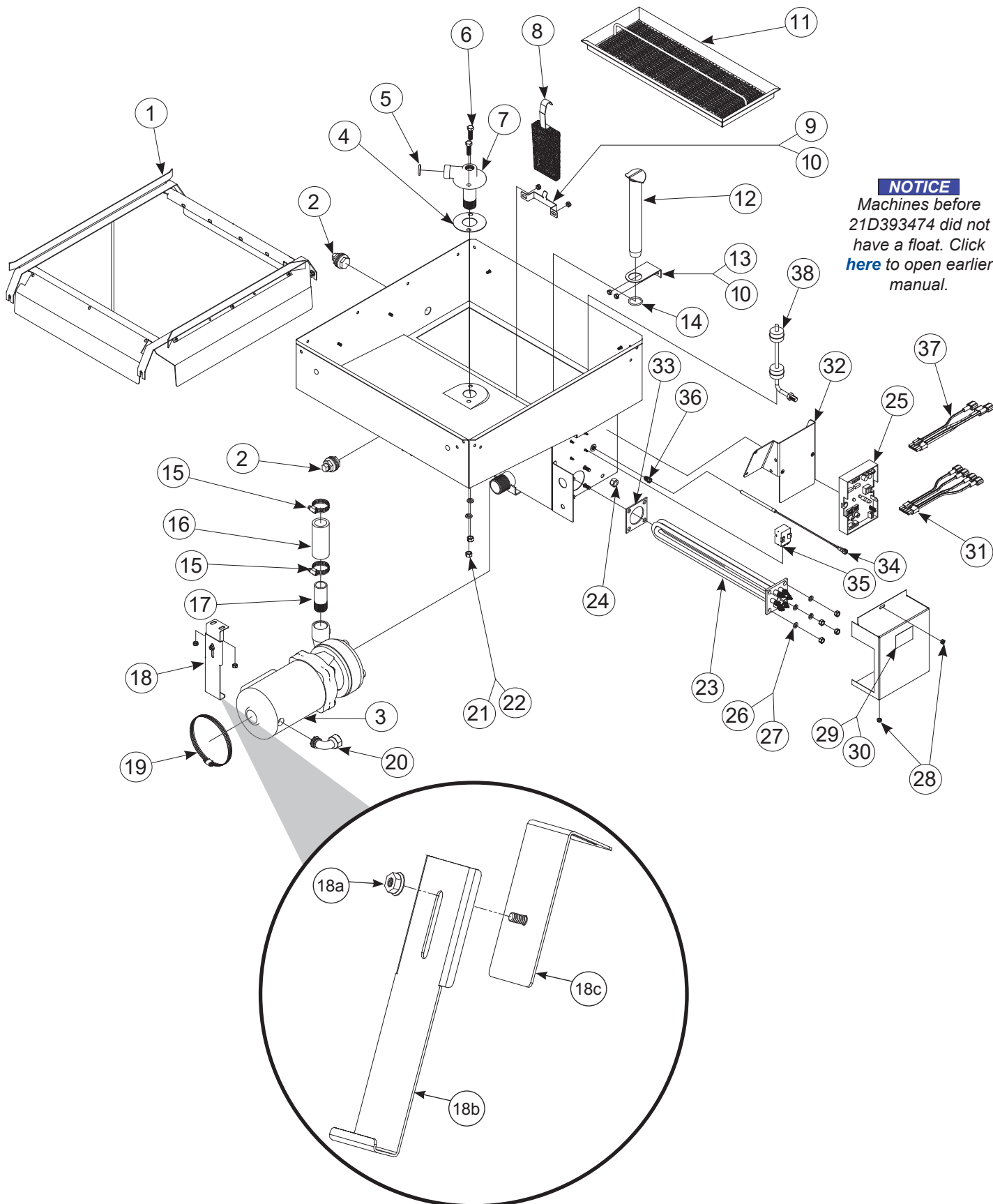

NOTICE
 Machines before 21D393474 did not have a float. Click [here](#) to open earlier manual.

ITEM	QTY	DESCRIPTION	PART NUMBER
1	1	Track Assembly	05700-002-01-00
2	2	Bulk Head Plug	04730-609-05-00
3	1	Wash Motor	See Motors page.
4	1	Gasket	05700-111-35-03
5	1	O-ring	05330-111-35-15
6	4	Bolt, Hex 3/8-16 x 1 1/4" Long	05305-276-10-00
7	1	Lower Wash Manifold	05700-031-46-00
8	1	Sump Strainer	05700-002-16-13
9	1	Bracket, Sump Strainer	05700-001-22-24
10	8	Locknut, 1/4-20 with Nylon Insert	05310-374-02-00
11	1	Scrap Screen	05700-003-07-76
12	1	Standpipe	05700-001-25-69
12a	1	Support, Ball Stop Lift (Not Shown)	05700-002-91-55
12b	1	Ball Stop Lift (Not Shown)	05700-002-91-54
13	1	Overflow Support Bracket	05700-001-27-55
13a	1	Shim, Overflow Support (Not Shown)	05700-002-96-48
14	1	O-ring	05330-400-05-00
15	2	Clamp, Hose 1 5/16" to 2 1/4"	04730-719-01-37
16	1	Discharge Hose	05700-011-88-24
17	1	Nipple	05700-021-34-84
18	1	Pump Support Bracket Assembly	05700-002-00-46
18a	1	Nut, 1/4-20 Hex Nut	05310-011-66-49
18b	1	Pump Support Adjustable Bracket	05700-002-20-41
18c	1	Bracket, Pump Support	05700-002-68-31
19	1	Clamp, Hose 5 5/8" to 6"	04730-011-34-90
20	1	Connector, 1/2"	05975-111-01-00
21	4	Nut, 3/8-16 Hex	05310-276-01-00
22	4	Lockwasher 3/8"	05311-276-01-00
23	1	Heater	See Heaters page.
24	1	Nut, Float Switch	05310-011-72-58
25	1	Thermostat, Elan Electric Dual	06685-004-17-27

ITEM	QTY	DESCRIPTION	PART NUMBER
26	4	Lockwasher, 5/16", Split	05311-275-01-00
27	4	Nut, Hex, 5/16-18	05310-275-01-00
28	4	Locknut, 10-24 with Nylon Insert	05310-373-01-00
29	1	Cover, Wash Heater	05700-031-47-57
30	1	Decal, Warning-Disconnect Power	09905-004-08-16
31	1	Harness, 5-Connector	05700-004-23-78
32	1	Thermostat Mounting Bracket	05700-004-22-17
33	1	Wash Heater Gasket	05330-011-47-79
34	1	Probe, Thermistor 4"	06685-004-17-26
35	1	Thermostat, High Limit	05930-004-33-12
36	1	Fitting, 1/4" Imperial Brass	05310-924-02-05
37	1	Harness, 4-Connector	05700-004-23-79
38	1	Float Switch	06680-121-70-71

NOTICE

Machines before
21D393474 did not
have a float. Click
[here](#) to open earlier
manual.

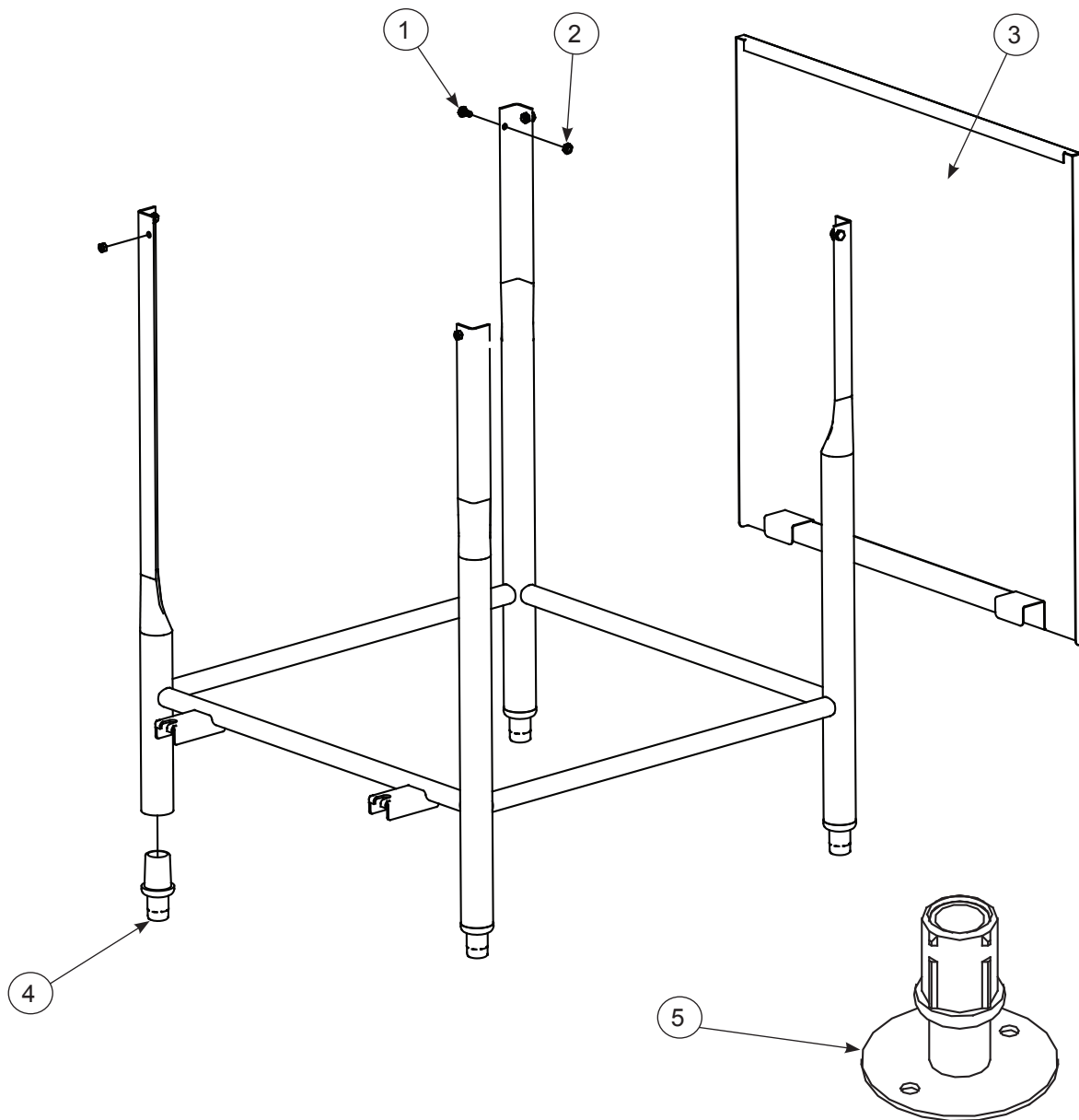

ITEM	QTY	DESCRIPTION	PART NUMBER
1	4	Bolt, 1/4-20 x 1/2"	05305-274-02-00
2	4	Locknut, 1/4-20 Hex with Nylon Insert	05310-374-02-00
3	1	Front Panel	05700-002-36-65
4	4	Bullet Foot	05340-108-01-03
5	4	Flanged Bullet Foot (Optional) (Back feet on FL/FL-VER)	05340-002-34-86

Complete Assemblies
 208-230 V, 14 kW 70° Rise - 05700-004-43-33
 208-230 V, 12 kW 40° Rise - 05700-004-52-19
 460 V, 14 kW 70° Rise - 05700-004-53-22
 460 V, 12 kW 40° Rise - 05700-004-53-21

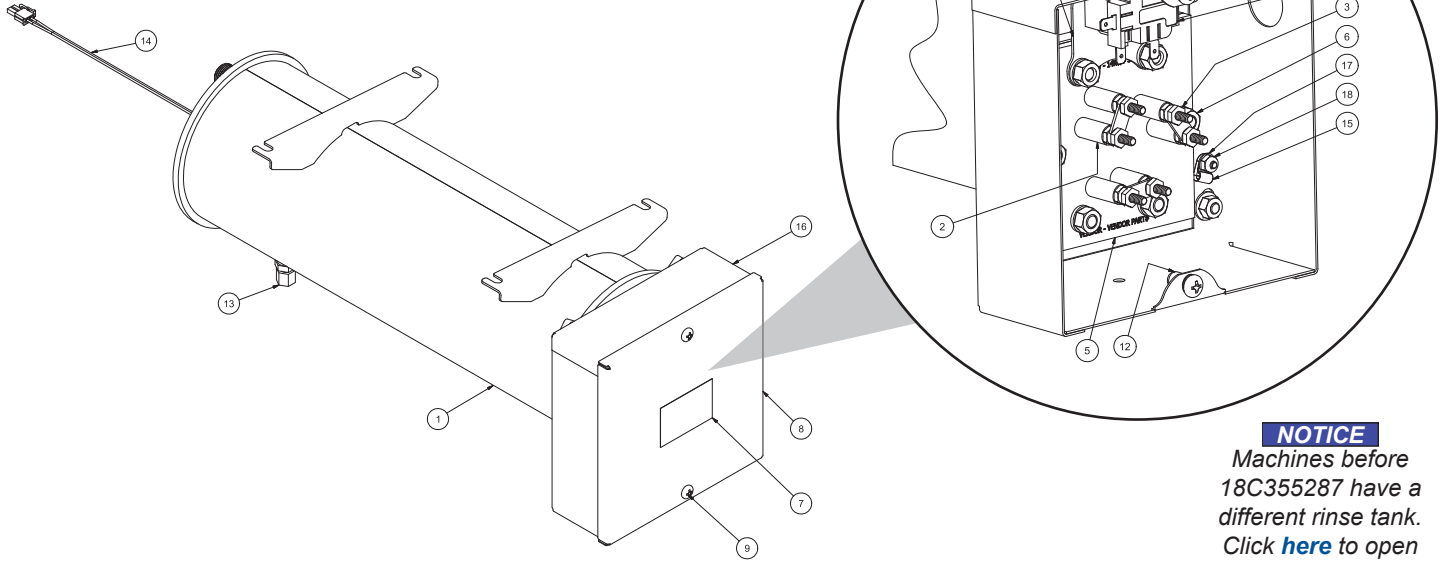

NOTICE
 Machines before 18C355287 have a different rinse tank. Click [here](#) to open earlier manual.

ITEM	QTY	DESCRIPTION	PART NUMBER
1	1	Tank, Rinse	05700-004-50-86
2	1	Heater, Rinse	See Heaters page.
3	6	Lockwasher, Split 5/16"	05311-275-01-00
4	1	Probe Fitting, 1/4" Brass Sleeve (Not Shown)	05310-924-02-05
5	1	Gasket, Rinse Heater	05330-200-02-70
6	6	Nut, Hex 5/16-18	05310-275-01-00
7	1	Decal, Warning-Disconnect Power	09905-004-08-16
8	1	Cover, Heater	05700-004-51-34
9	2	Screw	05305-004-27-82
10	1	Thermostat, High-limit	05930-004-33-12
11	1	Bracket, High-limit Thermostat	05700-004-36-84
12	2	Nut, 1/4-20	05310-004-23-96
13	1	Plug, 1/4" Brass	04730-209-01-00
14	1	Thermistor Probe	06685-004-17-26
15	1	Clamp, Wire 1/8", P-clip	05975-601-10-15
16	1	Cover Door, New Rinse Tank	05700-004-52-21
17	1	Washer, Flat	05311-173-02-00
18	1	Locknut, Hex 8-32	05310-272-02-00

Complete Assemblies

(See next page for parts.)

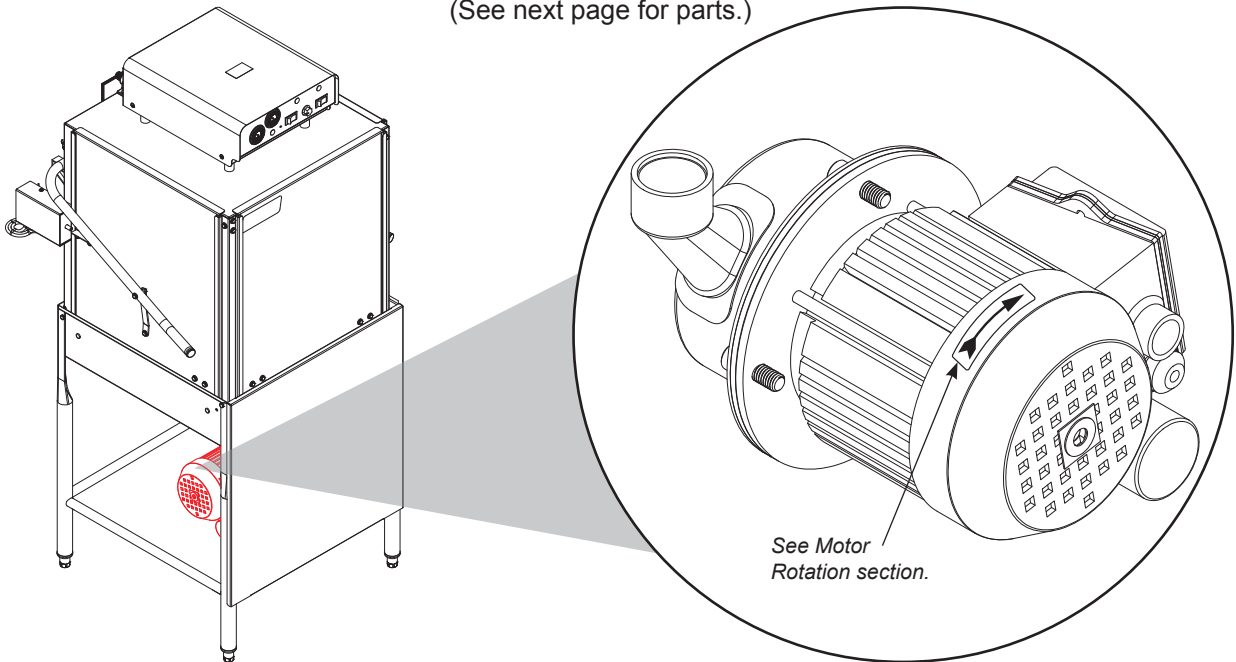

The models covered in this manual come supplied with various wash motor assemblies (a wash motor assembly includes the wash motor and the pump end), depending on the characteristics of the machine. To ensure you order the correct wash motor assembly for the model you are servicing, please refer to the following table:

MODEL	VOLTS	Hz	PHASE	WASH MOTOR ASSEMBLY
All	208	60	1	06105-004-24-80 ¹
All	208	60	3	06105-004-24-80 ¹
All	230	60	1	06105-004-24-80 ¹
All	230	60	3	06105-004-24-80 ¹
All	460	60	3	06105-121-64-21 ²

¹Use P/N 06105-004-32-04 to order the motor only.

²Use P/N 06105-002-62-71 to order the motor only.

NOTICE

When servicing a wash motor, it is important to refer to the wiring schematic found on the motor to ensure the motor is wired correctly. Different manufacturers of motors might not use the same wire color codes and your new motor might not connect using the same wires. Always refer to the wiring diagrams on the motor you are installing. If the motor you are installing has had the schematic removed, contact the manufacturer immediately for technical support.

Parts

(See previous page for complete assemblies.)

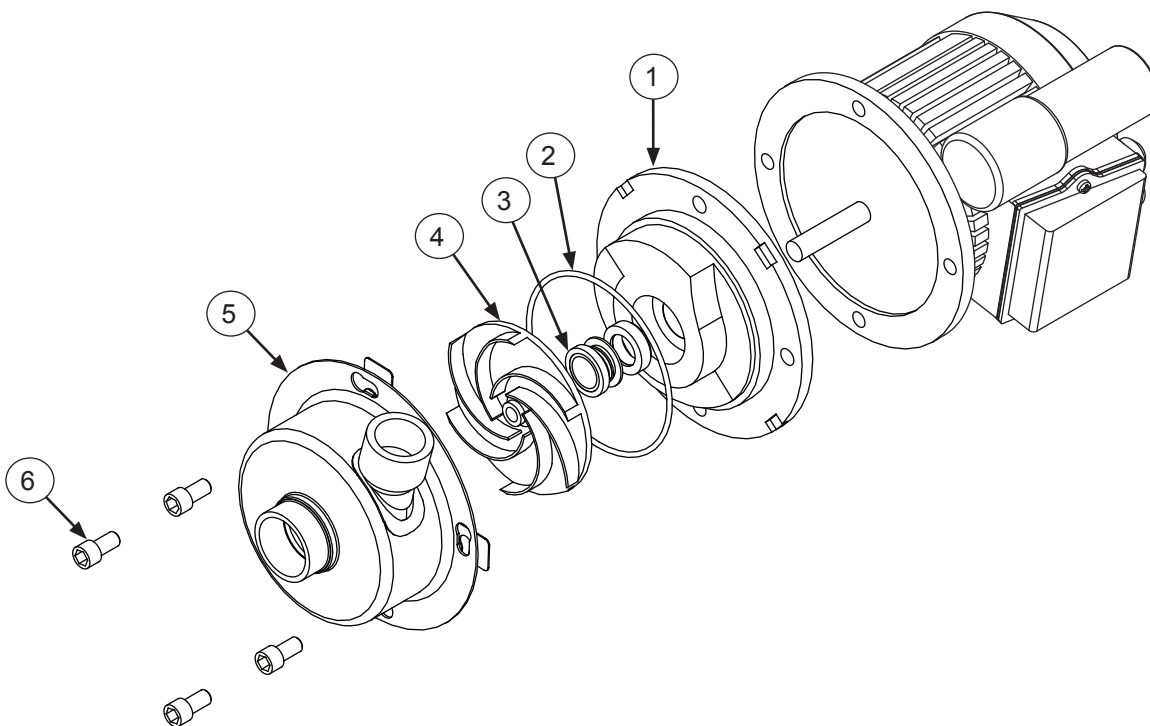

The models covered in this manual come supplied with various wash motors (see previous page), depending on the characteristics of the machine. To ensure you order the correct parts for the model you are servicing, please refer to the following table:

ITEM	QTY	DESCRIPTION	PART NUMBER
1	1	Seal Plate, 208/230 V	05700-002-81-87
	1	Seal Plate, 460 V	05700-002-06-22
2	1	Case O-ring	05330-002-81-83
3	1	Mechanical Seal, 208/230 V	05330-002-34-22
	1	Mechanical Seal, 460 V	05330-002-87-16
4	1	Impeller Assembly, 208/230 V	05700-002-81-86
	1	Impeller Assembly, 460 V	05700-002-06-19
5	1	Pump Casing 208/230 V	05700-002-85-01
	1	Pump Casing 460 V	05700-002-06-20
6	1	Case Capscrew, 208/230 V	05305-002-81-88

TempStar

Volts	Hz	Phase	Wash Heater	Rinse Heater (12 kW)	Rinse Heater (14 kW)
208	50	1	04540-121-47-39	04540-121-47-40	04540-121-63-38
208	50	3	04540-121-47-39	04540-121-47-40	04540-121-63-38
208	60	1	04540-121-47-39	04540-121-47-40	04540-121-63-38
208	60	3	04540-121-47-39	04540-121-47-40	04540-121-63-38
230	50	1	04540-121-47-39	04540-121-47-40	04540-121-63-38
230	50	3	04540-121-47-39	04540-121-47-40	04540-121-63-38
230	60	1	04540-121-47-39	04540-121-47-40	04540-121-63-38
230	60	3	04540-121-47-39	04540-121-47-40	04540-121-63-38
380	50	3	04540-002-44-31	04540-002-44-32	04540-121-63-38
415	50	3	04540-002-43-09	04540-002-43-10	N/A
440	50	3	04540-121-65-99	04540-100-01-15	04540-121-63-39
460	60	3	04540-121-65-99	04540-100-01-15	04540-121-63-39

TempStar VER

Volts	Hz	Phase	Wash Heater	Rinse Heater (14 kW)
208	50	1	04540-121-47-39	04540-121-63-38
208	50	3	04540-121-47-39	04540-121-63-38
208	60	1	04540-121-47-39	04540-121-63-38
208	60	3	04540-121-47-39	04540-121-63-38
230	50	1	04540-121-47-39	04540-121-63-38
230	50	3	04540-121-47-39	04540-121-63-38
230	60	1	04540-121-47-39	04540-121-63-38
230	60	3	04540-121-47-39	04540-121-63-38
380	50	3	04540-002-44-31	04540-121-63-38
415	50	3	04540-002-43-09	N/A
440	50	3	04540-121-65-99	04540-121-63-39
460	60	3	04540-121-65-99	04540-121-63-39

TempStar NB

Volts	Hz	Phase	Wash Heater
208	50	1	04540-121-47-39
208	50	3	04540-121-47-39
208	60	1	04540-121-47-39
208	60	3	04540-121-47-39
230	50	1	04540-121-47-39
230	50	3	04540-121-47-39
230	60	1	04540-121-47-39
230	60	3	04540-121-47-39
380	50	3	04540-002-44-31
415	50	3	04540-002-43-09
440	50	3	04540-121-65-99
460	60	3	04540-121-65-99

TempStar with Round-Flanged Rinse Heater

Volts	HZ	Phase	Wash Heater	Rinse Heater (12 kW)	Rinse Heater (14 kW)
208	50	1	04540-121-47-39	04540-003-58-27	04540-003-58-28
208	50	3	04540-121-47-39	04540-003-58-27	04540-003-58-28
208	60	1	04540-121-47-39	04540-003-58-27	04540-003-58-28
208	60	3	04540-121-47-39	04540-003-58-27	04540-003-58-28
230	50	1	04540-121-47-39	04540-003-58-27	04540-003-58-28
230	50	3	04540-121-47-39	04540-003-58-27	04540-003-58-28
230	60	1	04540-121-47-39	04540-003-58-27	04540-003-58-28
230	60	3	04540-121-47-39	04540-003-58-27	04540-003-58-28

Heater Phase Conversion Kit

06401-004-00-22

Complete Plumbing Assembly
05700-004-54-52

Top View

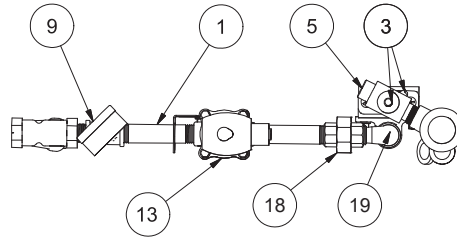

Back View

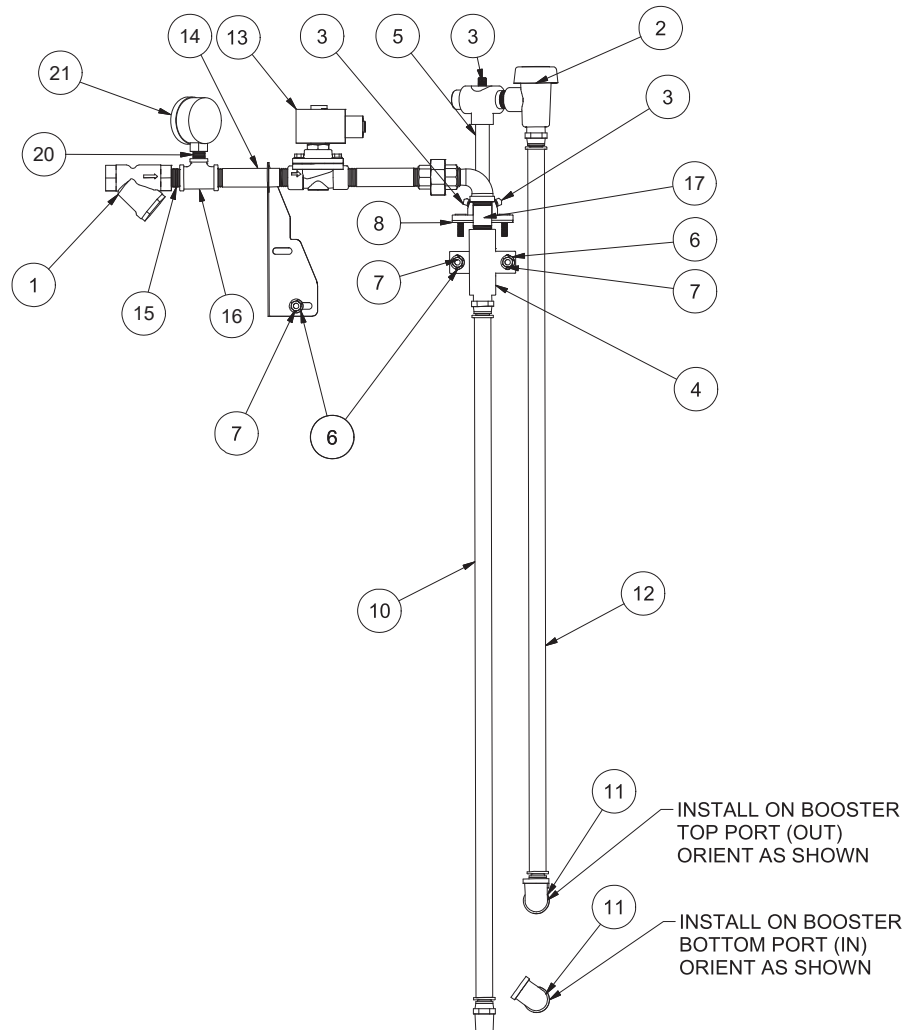

NOTICE

When servicing plumbing components, take care not to damage the threads of each individual item. Damaged threads can cause leaks and loss of pressure, which could adversely affect the performance of the machine. It is strongly recommended that thread tape—used in conservative amounts—be applied to threads when joining components together. Do not use thread-sealing compounds, sometimes referred to as “pipe dope.” Compounds can be ejected from the threads during the tightening process and become lodged in key components, rendering them useless, including solenoid valves and pressure gauge ball valves.

ITEM	QTY	DESCRIPTION	PART NUMBER
1	1	Y-strainer, 1/2"	04730-217-01-10
2	1	Vacuum Breaker, 1/2" Brass	04820-003-06-13
3	3	Plug, Rinse Injector, 1/8" Brass	04730-209-07-37
4	1	Casting, 1/2" Flanged Coupling	05700-004-47-97
5	1 1	Rinse Injector Gasket, Rinse Injector (Not Shown)	05700-004-26-98 05330-111-42-81
6	3	Washer, 1/4-20 Hex with Nylon Insert	05311-174-01-00
7	3	Locknut, 1/4-20 Hex with Nylon Insert	05310-374-01-00
8	1	Gasket, Rinse Manifold	05330-003-75-91
9	1	Decal, 10 PSI	09905-004-50-73
10	1	Hose, 1/2" x 31" Blue	05700-004-54-56
11	2	Elbow, 1/2" 90-degree Brass	04730-011-42-96
12	1	Hose, 1/2" x 33" Red	05700-004-51-62
13	1	Solenoid Valve, 1/2"	04810-003-71-56
14	2	Nipple, 1/2" x 4" Brass	04730-207-04-00
15	1	Nipple, 1/2" Brass	04730-207-15-00
16	1	Tee, 1/2" x 1/2" x 1/4"	04730-002-22-56
17	1	Nipple, 1/2" x 2" Brass	04730-207-19-00
18	1	Union, 1/2" x 1/2" Brass	04730-003-62-44
19	1	Elbow, 1/2" 90-degree Street Brass	04730-206-08-00
20	1	Ball Valve, 1/4" Bronze	04810-011-72-67
21	1	Pressure Gauge	06685-111-88-34

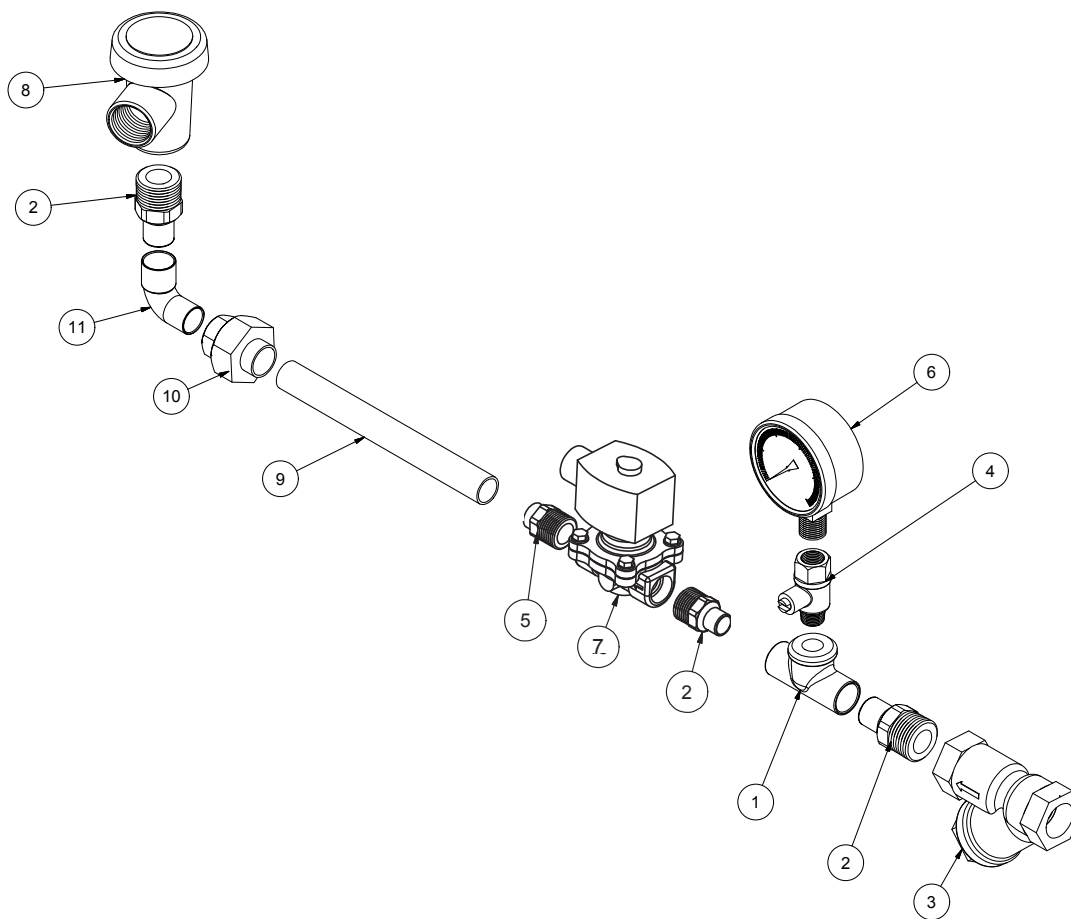

ITEM	QTY	DESCRIPTION	PART NUMBER
		Complete Assembly	05700-003-60-73
1	1	Tee, Brass, 1/2" x 1/2" x 1/4"	04730-411-25-01
2	3	Adapter, 1/2"	04730-011-59-53
3	1	Y-Strainer, 1/2"	04730-217-01-10
4	1	Ball Valve, Bronze, 1/4"	04810-011-72-67
5	1	Adapter, 1/2"	04730-401-03-01
6	1	Pressure Gauge, 0-100 PSI	06685-111-88-34
7	1	Valve, Solenoid, 1/2" 208-240 V	04810-003-71-56
8	1	Vacuum Breaker, 1/2"	04820-003-06-13
9	1	Tube, Copper 1/2" x 5 3/4"	05700-002-91-03
10	1	Union, 1/2"	04730-412-05-01
11	1	Elbow, 1/2" 90-Degree	04730-406-31-01

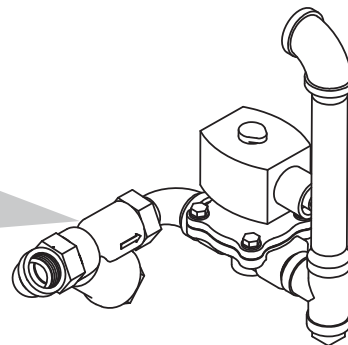
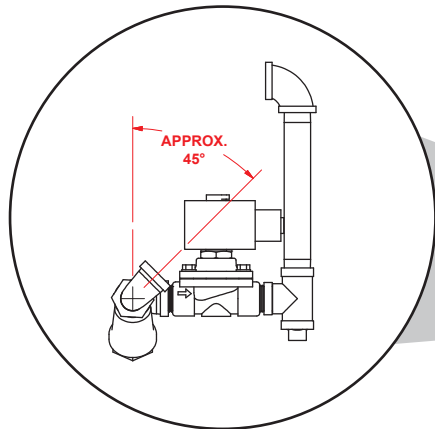
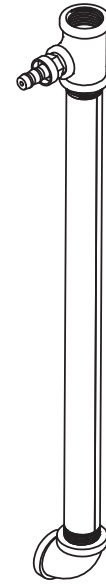
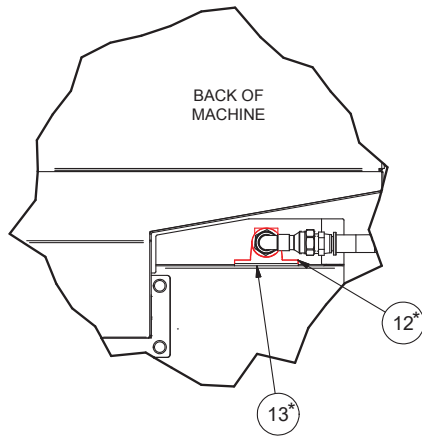

ITEM	QTY	DESCRIPTION	PART NUMBER
		Complete Assembly	05700-004-53-48
1	2	Elbow, 1/2", 90-degree Street Brass	04730-206-08-00
2	2	Nipple, 1/2" Close Brass	04730-207-15-00
3	1	Valve, Solenoid, 1/2" 208-240 V	04810-003-71-56
4	1	Y-Strainer, 1/2"	04730-217-01-10
5	2	Elbow, 1/2" 90-degree Brass	04730-011-42-96
6	1	Tee, 1/2" x 1/2" x 1/4"	04730-002-22-56
7	1	Fitting, 1/4" Barb x 1/4" Swivel	04730-011-95-41
8	1	Nipple, 1/2" x 1/4" Brass, Low PSI	05700-004-53-43
9	1	Tee, 1/2" Brass	04730-211-27-00
10	1	Nipple, 1/2" x 6" Brass	04730-003-62-38
11	1	Plug, 1/2" Brass Pipe	04730-209-03-00
12*	1	Rinse Injector, VER	09515-004-22-73
	3	Plug, Rinse Injector, 1/8" Brass (Not Shown)	04730-209-07-37
13*	1	Gasket, Rinse Injector	05330-111-42-81

*These items are not included in the complete plumbing assembly and must be ordered separately.

SHOCK ABSORBER (WATER ARRESTOR) OPTION

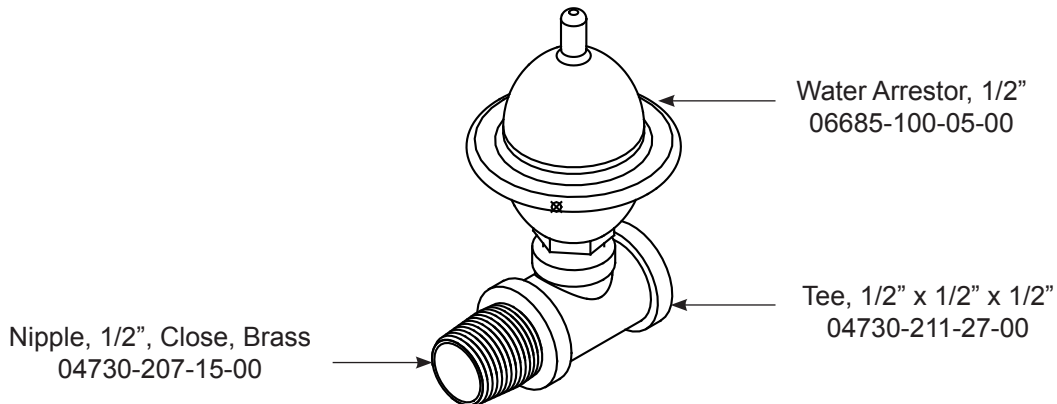

WATER TREATMENT OPTION

Scaltrol System
04730-003-05-76

Replacement Cartridge
(inspect at least every 6 months)
RSC-100

PRESSURE REGULATING VALVE OPTION*

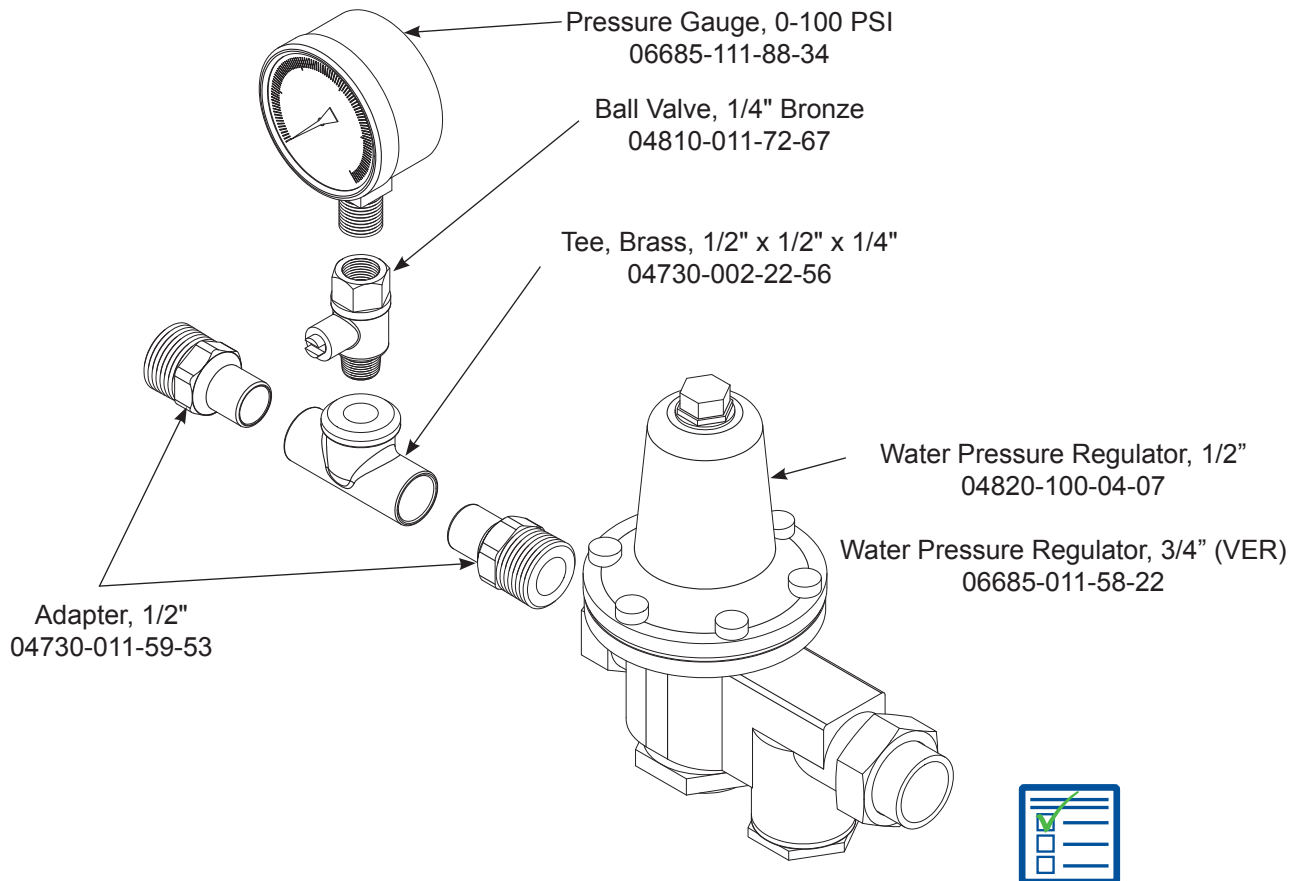

*PRV comes standard on the TempStar VER but ships inside the machine. Click [here](#) for install instructions.

FINAL RINSE ARMS & MANIFOLD

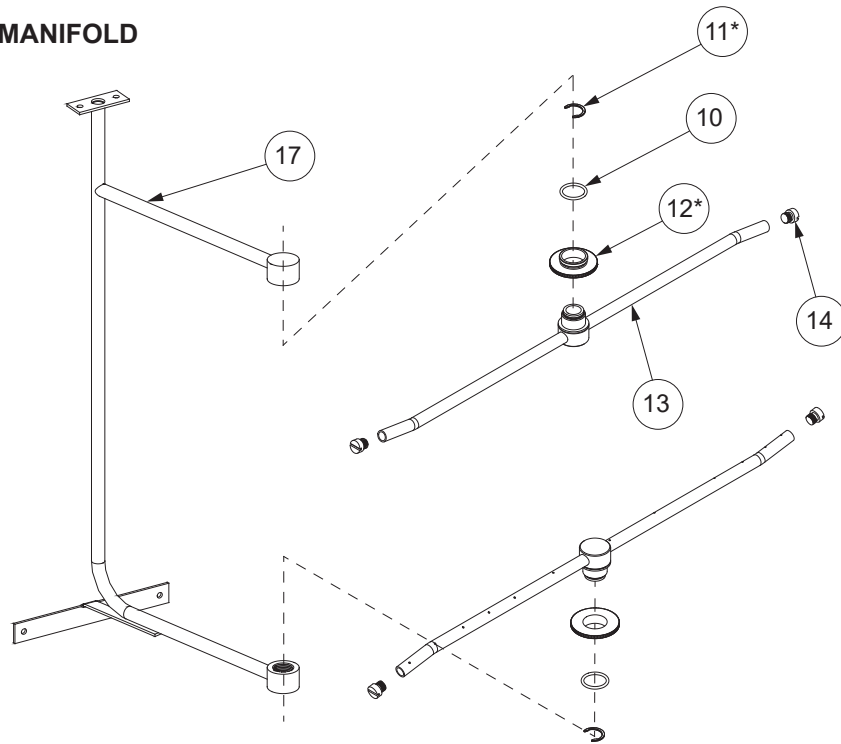

WASH ARMS & MANIFOLD

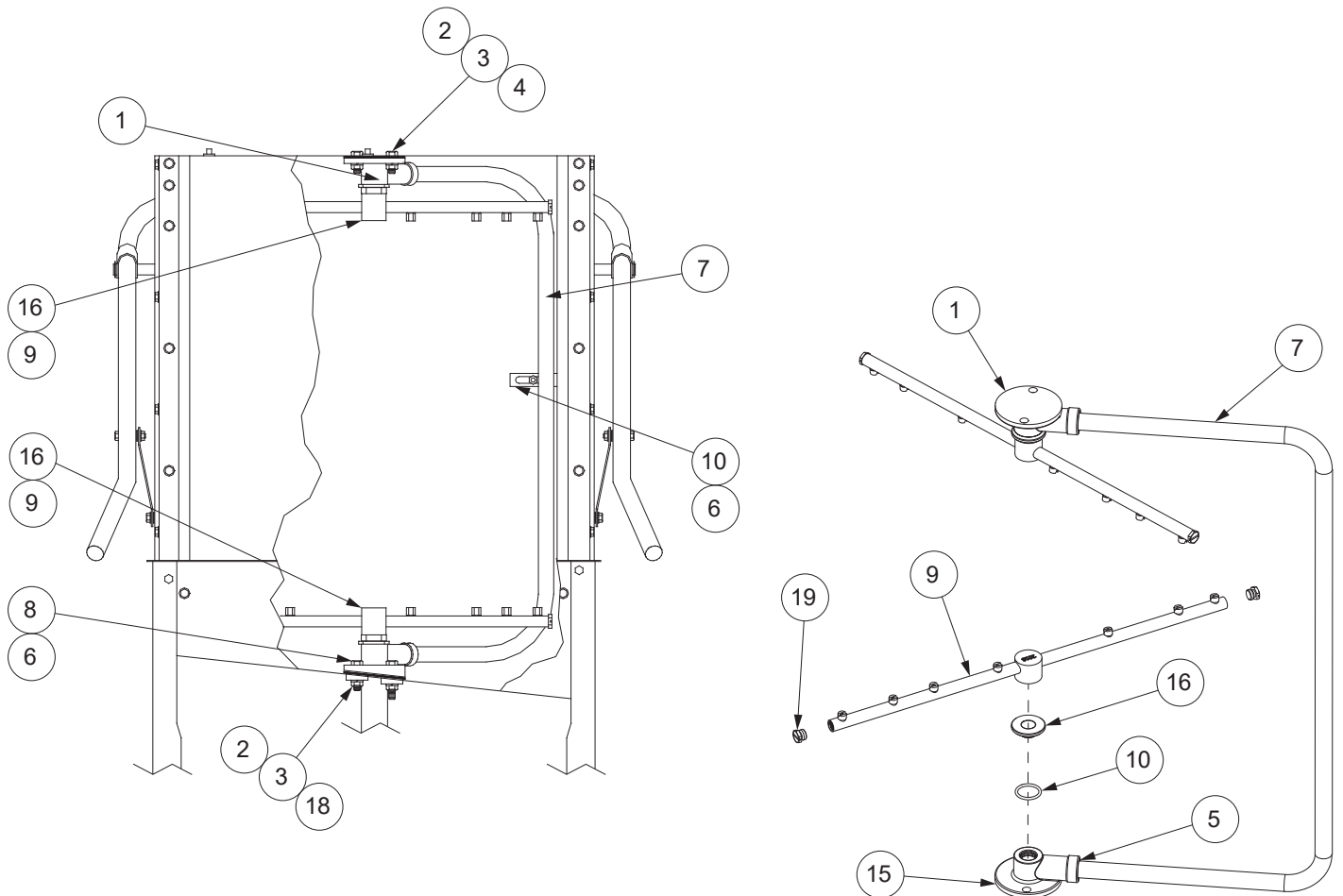

ITEM	QTY	DESCRIPTION	PART NUMBER
1	1	Upper Manifold	05700-031-34-82
2	4	Nut, 3/8-16 Hex	05310-276-01-00
3	4	Lockwasher, 3/8"	05311-276-01-00
4	2	Bolt, Hex 3/8-16 x 7/8"	05306-011-36-95
5	2	O-ring	05330-111-35-15
6	1	Positioning Bracket, Manifold Tube	05700-011-34-63
7	1	Tube, Wash Manifold	05700-131-15-07
8	2	Gasket, Manifold	05700-111-35-03
9	1	Wash Arm	05700-004-13-13
10	4	O-ring, Silicone 13/16" ID x 1" OD	05330-002-60-69
11*	2	Clip, Retaining, Rinse Head Bushing	05340-112-01-11
12*	2	Bearing Assembly, Rinse Arm	05700-004-54-71
13	2	Rinse Arm	05700-003-58-94
14	4	Rinse Arm End-cap	04730-111-60-41
15	1	Lower Wash Manifold	05700-031-46-00
16	2	Bearing Assembly	05700-021-35-97
17	1	Rinse Manifold Assembly	05700-021-47-61
18	2	Bolt, Hex 3/8-16 x 1 1/4"	05305-276-10-00
19	4	Wash Arm End-cap	05700-003-31-59

*Rinse Arm Bearing Kit
(Includes items 11 and 12)
06401-004-57-50

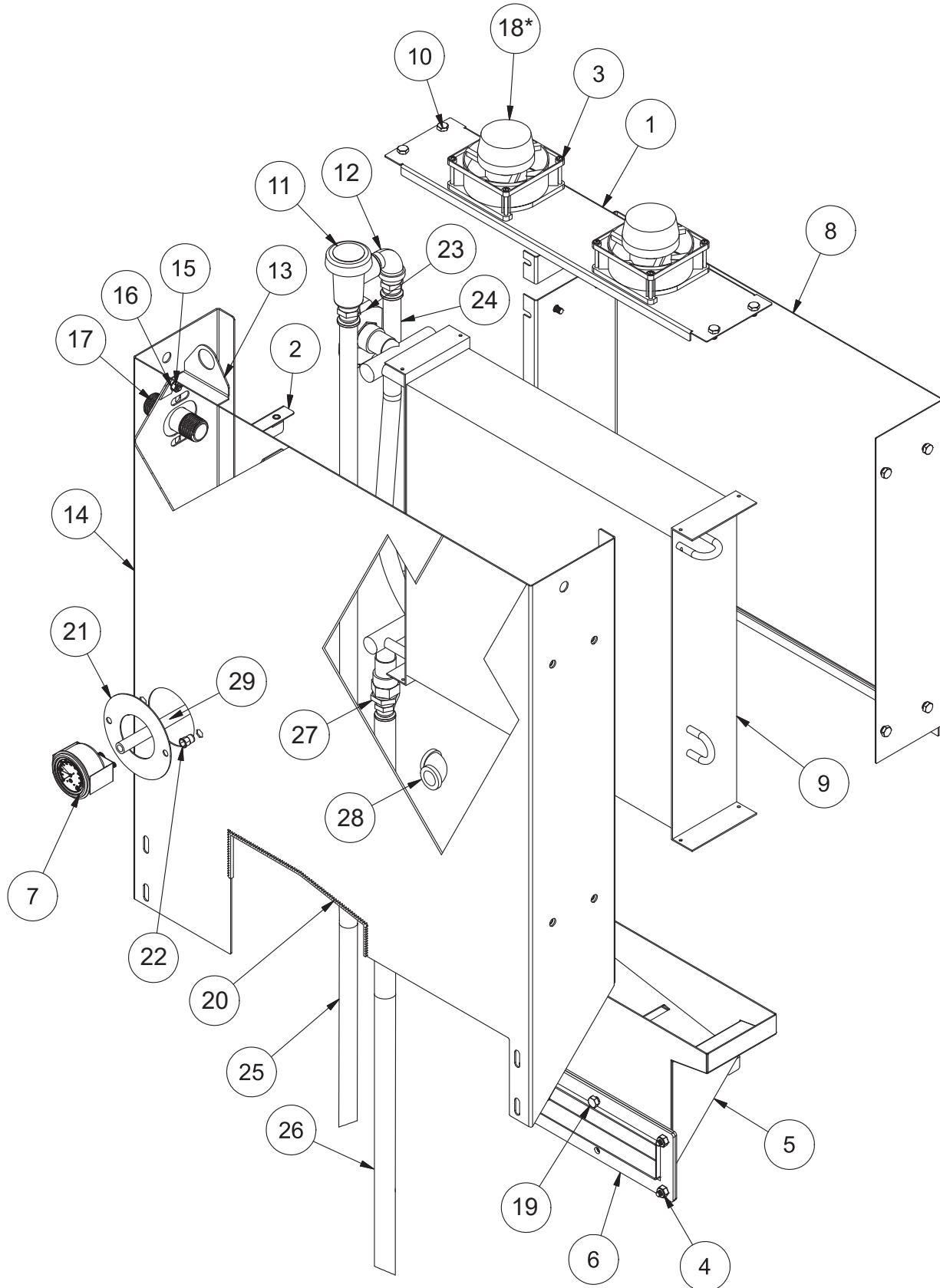

ITEM	QTY	DESCRIPTION	PART NUMBER
	1	VER System, Complete Assembly	05700-004-53-47
1	1	Plate, Fan Mounting	05700-004-18-07
2	1	Upper Shroud	05700-004-18-06
3	8	Screw, 6-32 x 1 3/4"	05305-004-19-80
4	4	Locknut, 1/4-20 Hex with Nylon Insert	05310-374-01-00
5	1	Exhaust Box	05700-004-18-04
6	1	Gasket, Heat Exchanger	05330-004-18-22
7	1	Gauge	06680-004-19-78
8	1	Coil Box, Back	05700-004-18-03
9	1	Coil, Heat Exchanger	04420-004-19-61
10	12	Bolt, 1/4-20 x 3/8" Hex	05305-274-20-00
11	1	Vacuum Breaker, 1/2" Brass	04820-003-06-13
12	1	Elbow, 1/2", 90-degree Street Brass	04730-206-08-00
13	1	Bracket, Vacuum Breaker	05700-004-18-91
14	1	Shroud, Heat Exchanger	05700-004-18-92
15	6	Locknut, 10-24 Hex with Nylon Insert	05310-373-01-00
16	6	Washer, Flat	05311-173-02-00
17	1	Inlet, Cold Water	05700-004-19-01
18*	2	Fan, 85-236 V AC* Fan, 24 V DC*	05999-004-19-46* 05999-004-81-80*
19	2	Screw, 1/4-20 x 5/8" Hex Head	05305-274-24-00
20	1	Edge Protector	05700-004-25-62
21	1	Ring, Pressure Gauge	05700-004-35-70
22	4	Nut, 1/4-20	05310-004-23-96
23	1	Bracket, Water Inlet	05700-004-41-27
24	1	Hose, 1/2" x 24" Red	05700-004-19-89
25	1	Hose, 1/2" x 38" Red	05700-004-31-81
26	1	Hose, 1/2" x 48" Blue	05700-004-48-23
27	1	Bushing, 3/4" x 1/2"	04730-002-56-27
28	1	Elbow, 1/2", 90-degree Brass	04730-011-42-96
29	1	Hose, 1/4" x 30" Black	05700-004-63-75

*Confirm fans are AC or DC before ordering.

Complete Interlock Assembly
05700-004-97-05

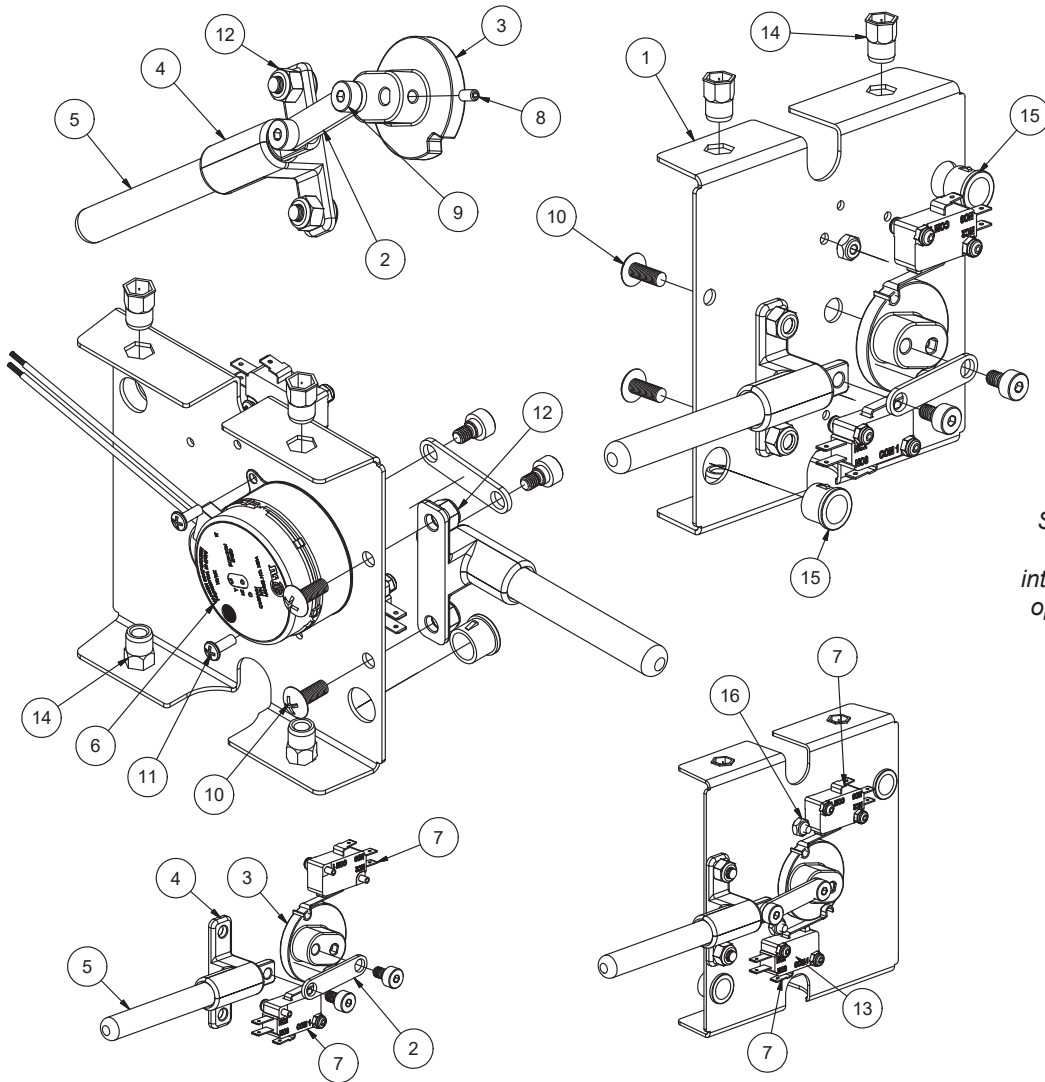

NOTICE
Some models have a different door interlock. Click [here](#) to open earlier manual.

Complete Interlock Box Assembly (includes above)
05700-004-97-06

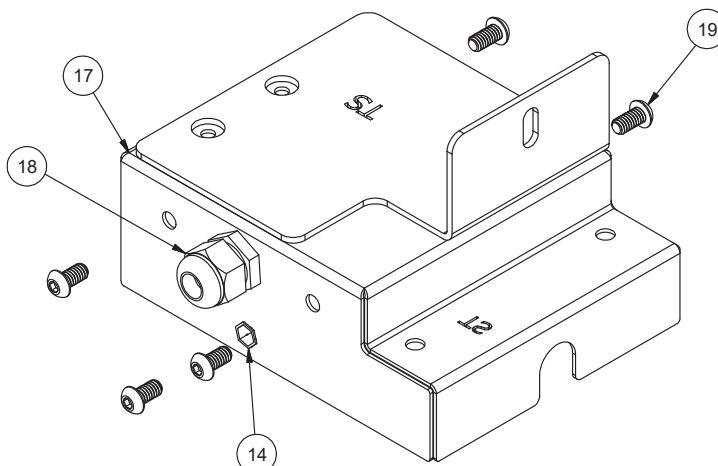

ITEM	QTY	DESCRIPTION	PART NUMBER
1	1	Plate, Interlock	05700-004-97-10
2	1	Link, Interlock Connector	05700-004-71-37
3	1	Interlock Cam	05700-004-71-39
4	1	Interlock Guide	05700-004-71-50
5	1	Pin, Interlock	05700-004-71-49
6	1	Motor, Interlock	06105-004-70-04
7	2	Switch, Interlock	05930-004-71-36
8	1	Set Screw, 6-32 x 1/4"	05305-004-71-42
9	2	Shoulder Screw, 10-32	05305-004-71-40
10	2	Screw, 10-32 x 1/2"	05305-011-39-36
11	2	Screw, 6-32 x 3/8"	05305-171-02-00
12	2	Locknut, 10-32 with Nylon Insert	05310-373-02-00
13	5	Locknut, 4-40	05310-279-06-00
14	8	Insert, Threaded Hex 1/4-20	05310-004-23-96
15	2	Bushing, Lock	05975-210-05-00
16	2	Locknut, 6-32 with Nylon Insert	05310-373-03-00
17	1	Box, Door Interlock	05700-004-99-16
18	1	Fitting	05975-011-49-03
19	6	Screw, 1/4-20 x 1/2" Button Head Hex	05305-004-62-33

FL-VER Door Interlock Assembly
05700-005-05-42

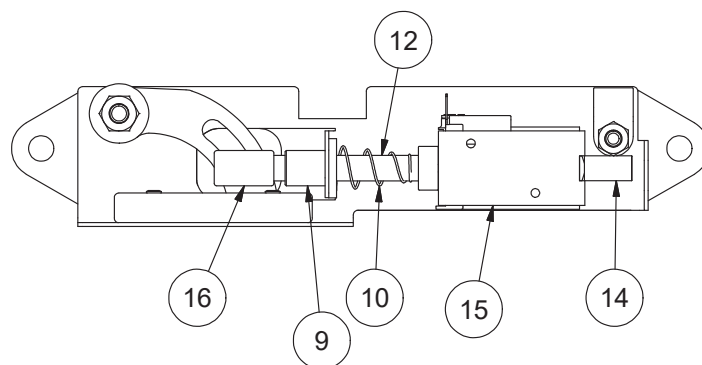
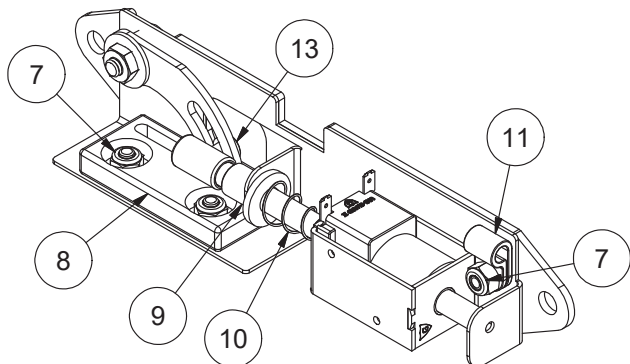
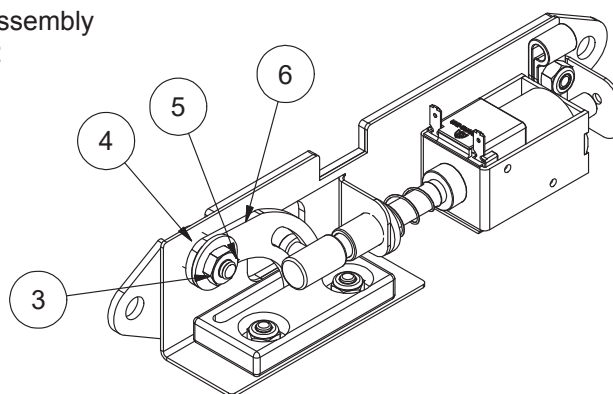
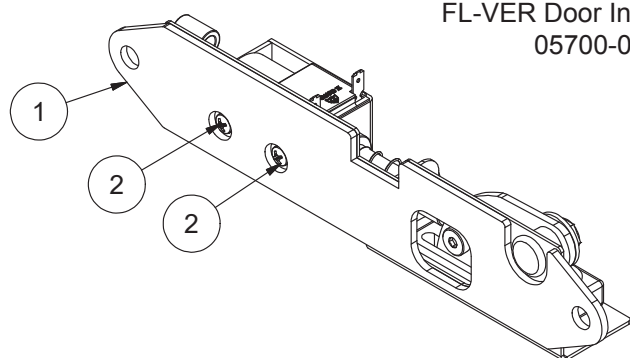

ITEM	QTY	DESCRIPTION	PART NUMBER
1	1	Bracket, Solenoid Guide	05700-005-05-41
2	2	Screw, 6-32 x 1/8"	05305-004-51-01
3	1	Locknut, 1/4-20 Low Profile with Nylon Insert	05310-374-02-00
4	1	Bushing, Door Interlock Latch Pivot	09330-005-06-56
5	1	Washer, 1/4-20 x 3/4" OD	05311-011-76-30
6	1	Latch, Door Interlock	05700-005-05-38
7	3	Locknut, 10-24 Hex with Nylon Insert	05310-373-01-00
8	1	Block, Latch Guide	09330-005-05-43
9	1	Bushing, Door Interlock Pin	09330-005-06-57
10	1	Spring, Conical Compression	05340-004-47-53
11	1	P-clamp, 1/4" ID	05975-002-61-42
12	1	Pin, Door Interlock	09515-005-05-36
13	1	Screw, 10-32	05305-005-05-44
14	1	Solenoid Rod, Door Interlock	09515-005-05-56
15	1	Solenoid	05999-004-47-49
16	1	Bushing, Interlock Pin Cap	09330-005-06-58

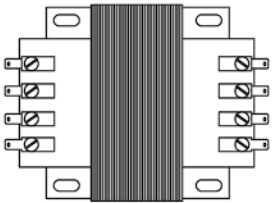

460 V Transformer
05950-111-65-93

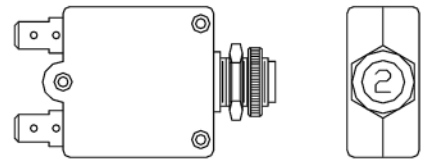
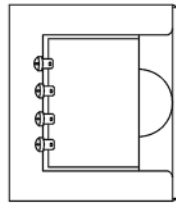

2 A Circuit Breaker
05925-111-64-18

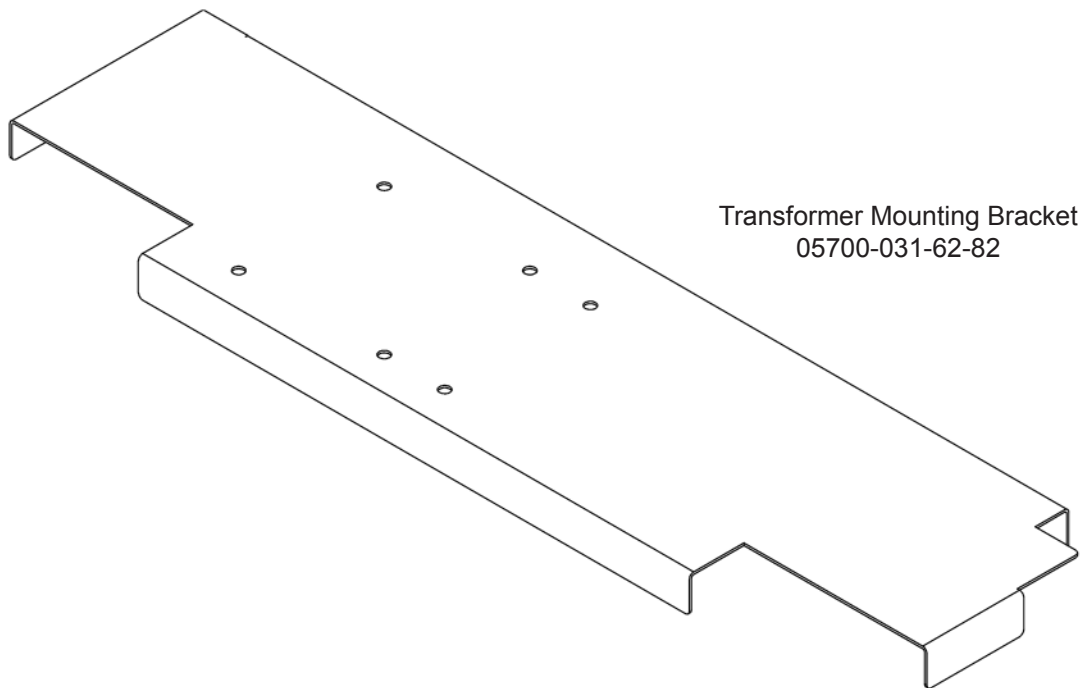

Transformer Mounting Bracket
05700-031-62-82

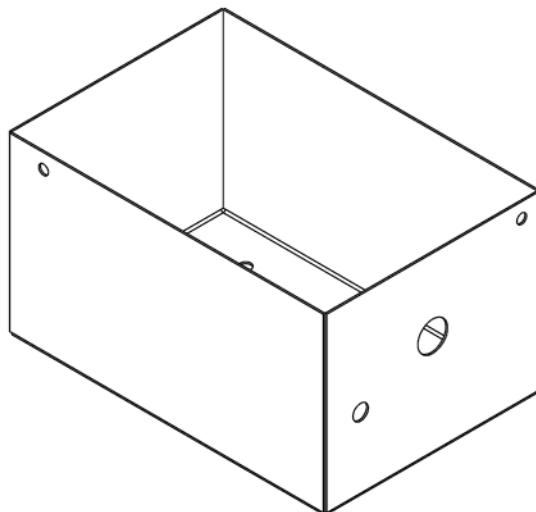

Transformer Mounting Box
05700-002-10-01

Transformer Mounting Box Top
(Not Shown)
05700-000-78-53

Call 1-880-800-5672 to order kits for TempStar models and use the part numbers below:

DESCRIPTION	PART NUMBER
VER Door Interlock Kit	06401-004-03-23
Door Magnet Cover Kit	06401-004-07-73
Drain Water Tempering Kit	06401-004-85-80
Exhaust Fan Contactor Kit	05700-004-35-35
False Panel Kit	05700-002-75-59
Phase Conversion Kit	06401-004-00-22
Fans Conversion Kit, AC to DC	06401-004-83-93
TempStar Go Box*	06401-003-62-04

*The Go Box is a kit of the most-needed parts to successfully complete a repair in the first call 90% or more of the time.

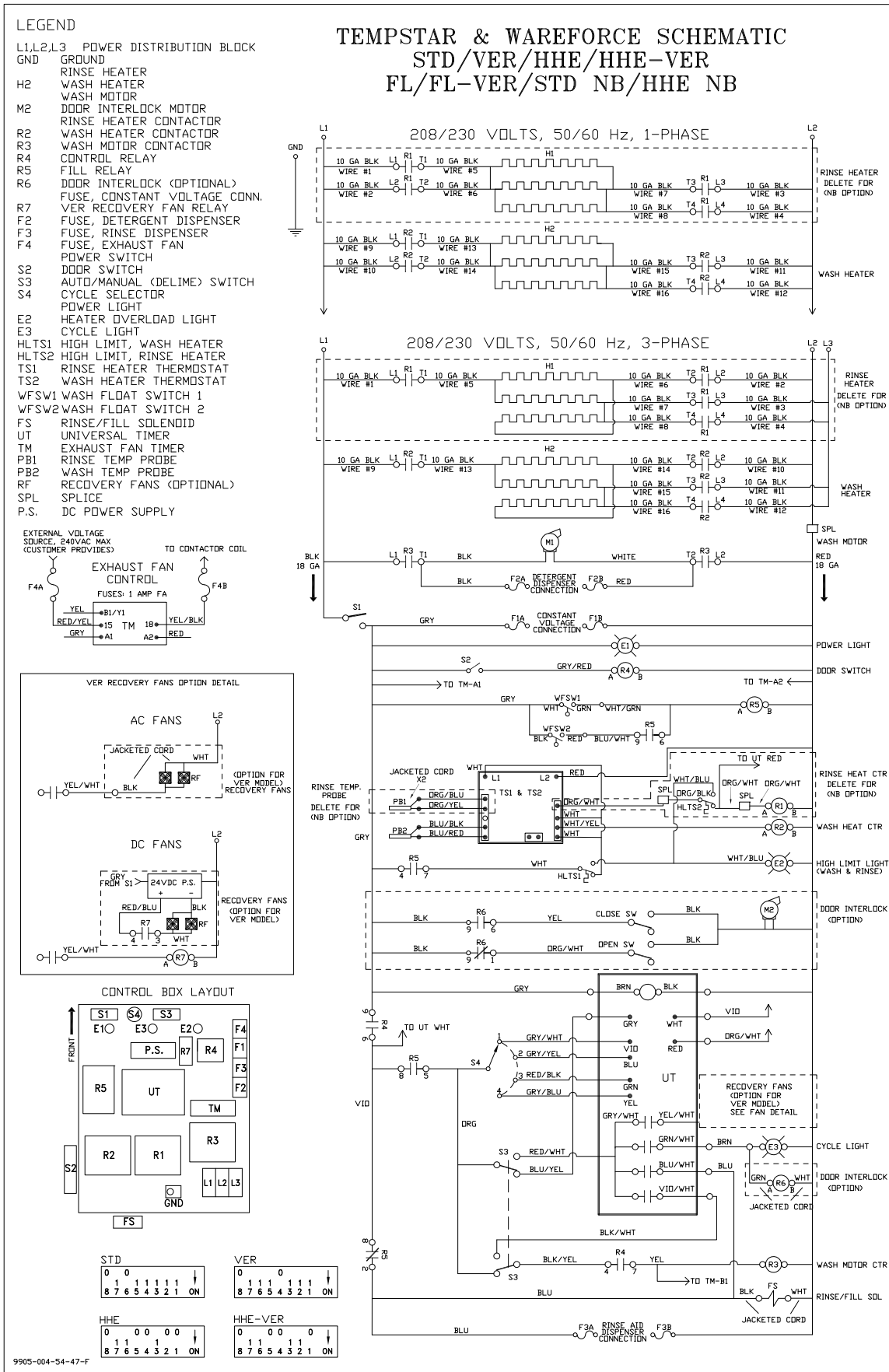

LEGEND

- L1,L2,L3 POWER DISTRIBUTION BLOCK
- GND GROUND
- H1 RINSE HEATER
- H2 WASH HEATER
- M1 WASH MOTOR
- R1 RINSE HEATER CONTACTOR
- R2 WASH HEATER CONTACTOR
- R3 WASH MOTOR CONTACTOR
- R4 CONTROL RELAY
- R5 FILL RELAY
- F1 FUSE, CONSTANT VOLTAGE CONN.
- F2 FUSE, DETERGENT DISPENSER
- F3 FUSE, RINSE DISPENSER
- F4 FUSE, EXHAUST FAN
- S1 POWER SWITCH
- S2 DOOR SWITCH
- S3 AUTO/MANUAL (DELIME) SWITCH
- S4 CYCLE SELECTOR
- E1 POWER LIGHT
- E2 HEATER OVERLOAD LIGHT
- E3 CYCLE LIGHT
- HLTS1 HIGH LIMIT, WASH HEATER
- HLTS2 HIGH LIMIT, RINSE HEATER
- TS1 RINSE HEATER THERMOSTAT
- TS2 WASH HEATER THERMOSTAT
- WFSW1 WASH FLOAT SWITCH 1
- WFSW2 WASH FLOAT SWITCH 2
- FS RINSE/FILL SOLENOID
- UT UNIVERSAL TIMER
- TM EXHAUST FAN TIMER
- PB1 RINSE TEMP PROBE
- PB2 WASH TEMP PROBE
- RF RECOVERY FANS (OPTIONAL)
- DI DOOR INTERLOCK (OPTIONAL)
- SPL SPLICE
- T1 CONTROL TRANSFORMER
- MOL MOTOR OVERLOAD
- CF CONTROL FUSE
- P.S. 24VDC POWER SUPPLY
- R7 VER RECOVERY FAN RELAY

TEMPSTAR & WAREFORCE SCHEMATIC
STD/VER/HHE/HHE-VER
FL/FL-VER/STD NB/HHE NB

460 VOLTS, 50/60 Hz, 3-PHASE

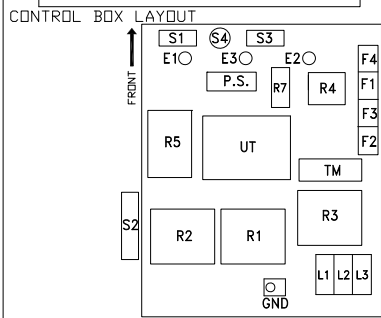
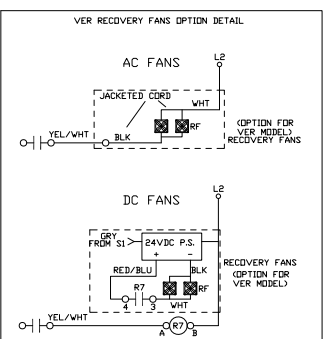
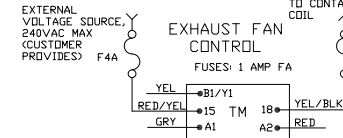
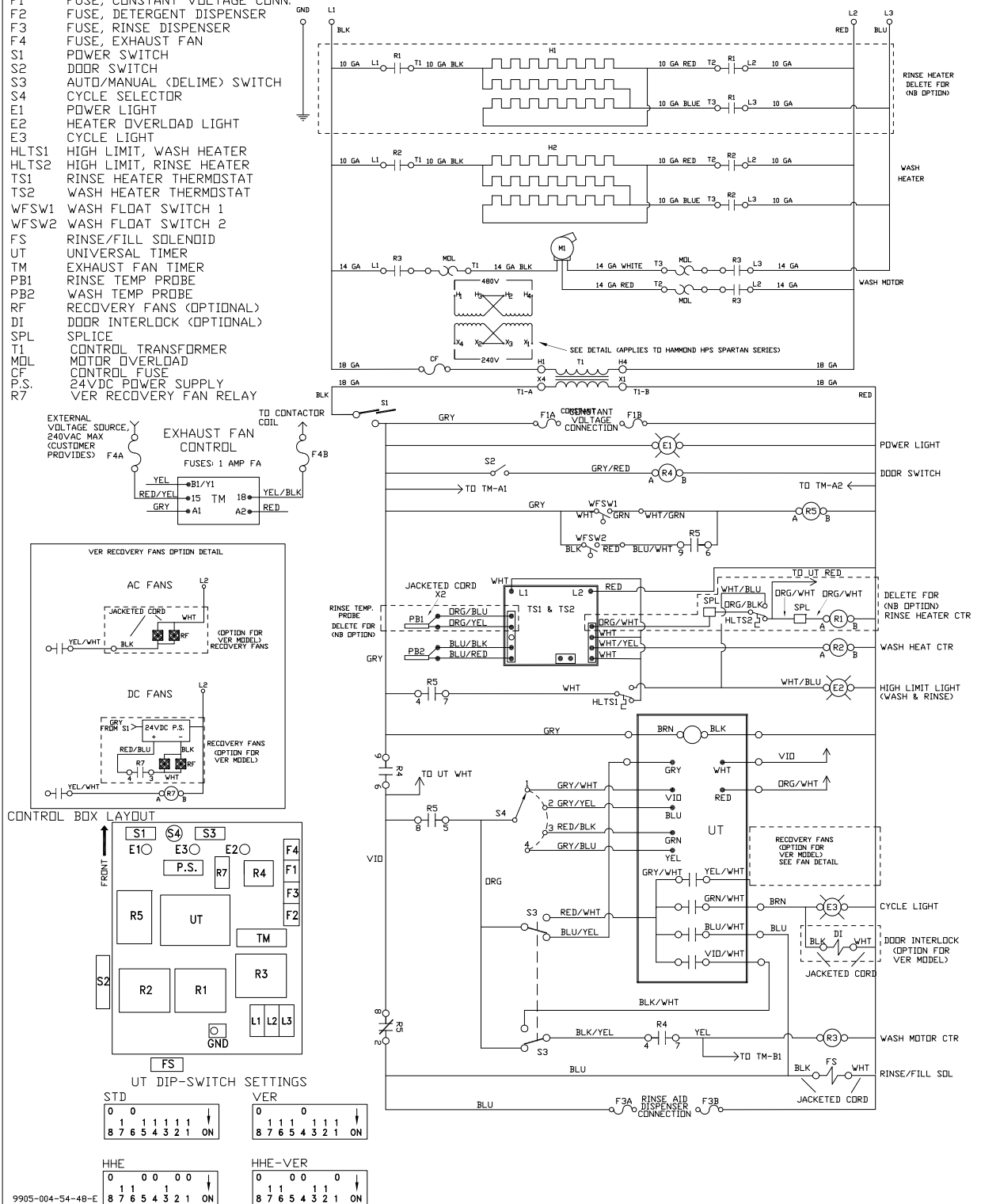

UT DIP-SWITCH SETTINGS

STD	VER
0 0	0 0
1 1 1 1 1 1 1 1	1 1 1 1 1 1 1 1
8 7 6 5 4 3 2 1 ON	8 7 6 5 4 3 2 1 ON

HHE	HHE-VER
0 0 0 0 0 0	0 0 0 0
1 1 1 1 1 1 1 1	1 1 1 1 1 1 1 1
8 7 6 5 4 3 2 1 ON	8 7 6 5 4 3 2 1 ON

**TEMPSTAR SCHEMATIC
NB/HH-NB/HHE-NB**

LEGEND

- L1,L2,L3 POWER DISTRIBUTION BLOCK
- GND GROUND
- H2 WASH HEATER
- M1 WASH MOTOR
- R2 WASH HEATER CONTACTOR
- R3 WASH MOTOR CONTACTOR
- R4 CONTROL RELAY
- F1 CONSTANT VOLTAGE CONNECTION
- F2 DETERGENT DISPENSER FUSE BLOCK
- F3 RINSE DISPENSER FUSE BLOCK
- F4 EXHAUST FAN FUSE BLOCK
- S1 POWER SWITCH
- S2 DDDR SWITCH
- S3 AUTO/MANUAL (DELIME) SWITCH
- S4 CYCLE SELECTOR
- E1 POWER LIGHT
- E2 HEATER OVERLOAD LIGHT
- E3 CYCLE LIGHT
- HLTS WASH HEATER HIGH LIMIT
- TS2 WASH HEATER THERMOSTAT
- HP HIGH WATER LEVEL PROBE
- WL WATER LEVEL CONTROL
- FS RINSE/FILL SOLENOID
- UT UNIVERSAL TIMER
- TM EXHAUST FAN TIMER
- PB2 WASH TEMP PROBE
- SPL SPLICE

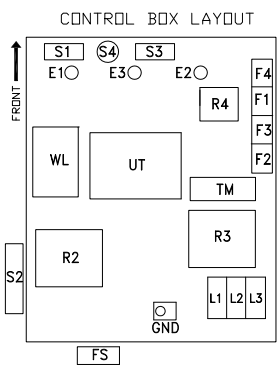
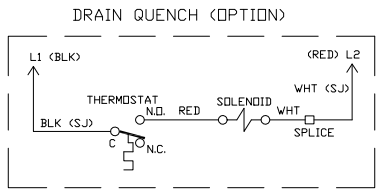
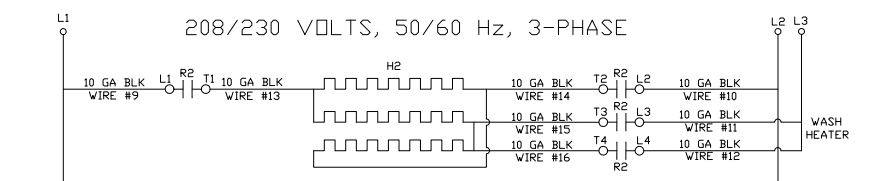
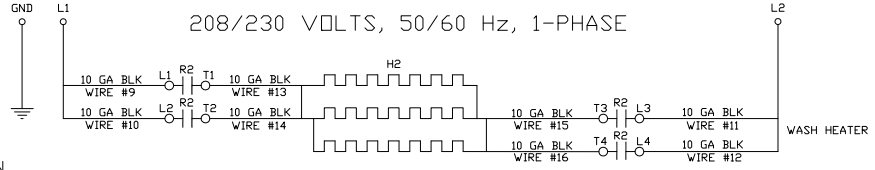

UT DIP-SWITCH SETTINGS

NB							
0	0						
1	1	1	1	1	1	1	↓
8	7	6	5	4	3	2	1 ON

HH-NB							
0		0	0	0			
1	1	1			1		↓
8	7	6	5	4	3	2	1 ON

HHE-NB							
0		0	0	0	0		
1	1				1		↓
8	7	6	5	4	3	2	1 ON

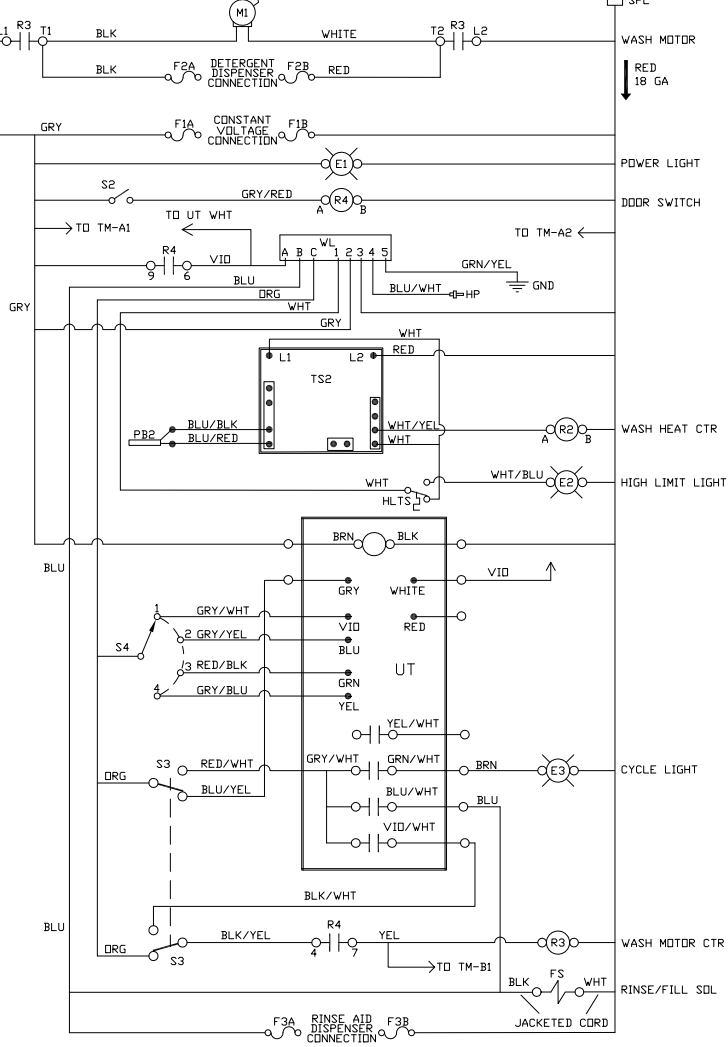
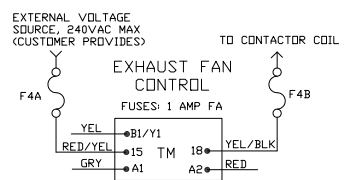

TEMPSTAR SCHEMATIC
NB/HH-NB/HHE-NB
460 VOLTS, 50/60Hz, 3-PHASE

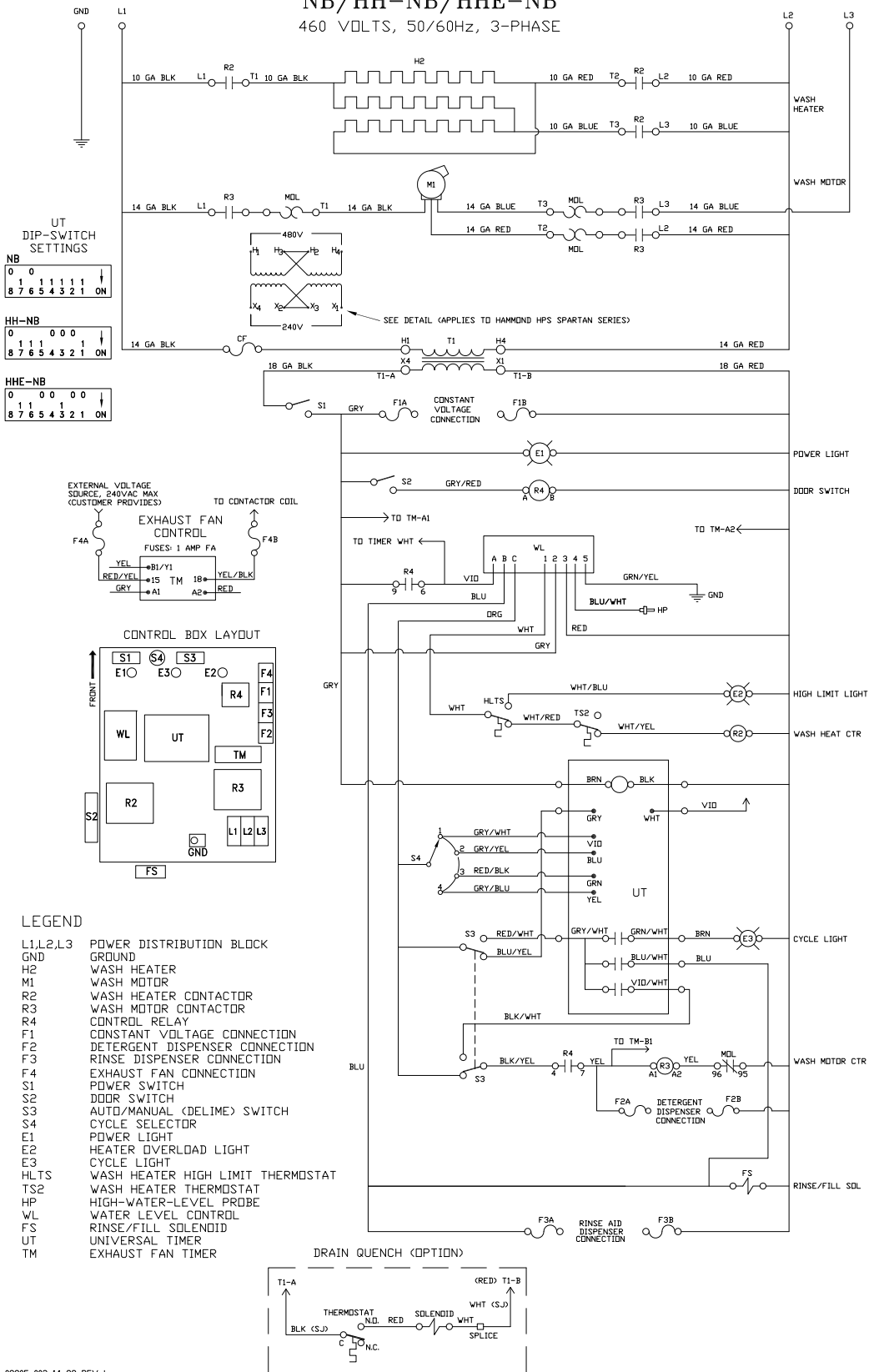

TEMPSTAR SDI OPTION FOR 208/230 VAC CIRCUIT

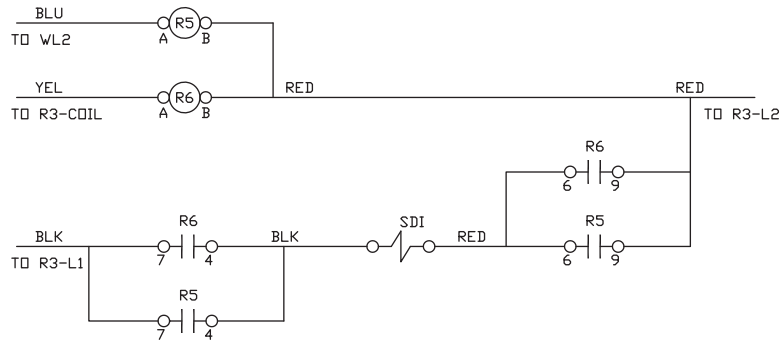

LEGEND

- R5 RELAY, RINSE
- R6 RELAY, WASH
- SDI SOLENOID, SAFETY DOOR INTERLOCK

09905-002-35-85 REV B

TEMPSTAR SDI OPTION FOR 120 VAC CIRCUIT

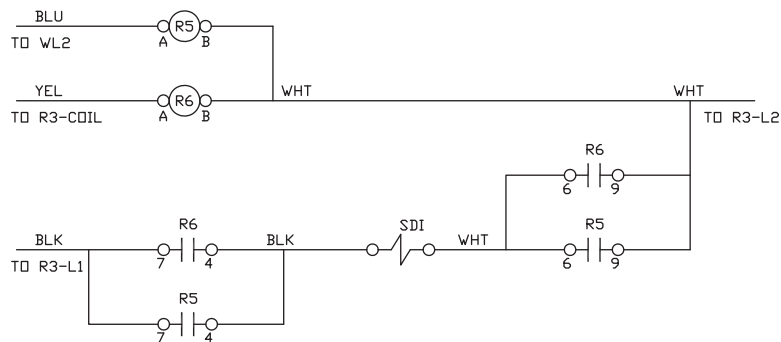

LEGEND

- R5 RELAY, RINSE
- R6 RELAY, WASH
- SDI SOLENOID, SAFETY DOOR INTERLOCK

09905-002-55-78 REV B

INSTALLATION, OPERATION, AND SERVICE MANUAL

TEMPSTAR SERIES DOOR-TYPE DISHMACHINES



Jackson WWS, Inc. • 6209 N. US Hwy 25E • Gray, KY 40734 USA
1.888.800.5672 • www.jacksonwws.com

TempStar Manual • 07610-003-61-42-AA