

Carbonators

43 Series / E Series

Project _____
 Item _____
 Quantity _____
 CSI Section 11400
 Approved _____
 Date _____

Carbonators
43 Series / E Series

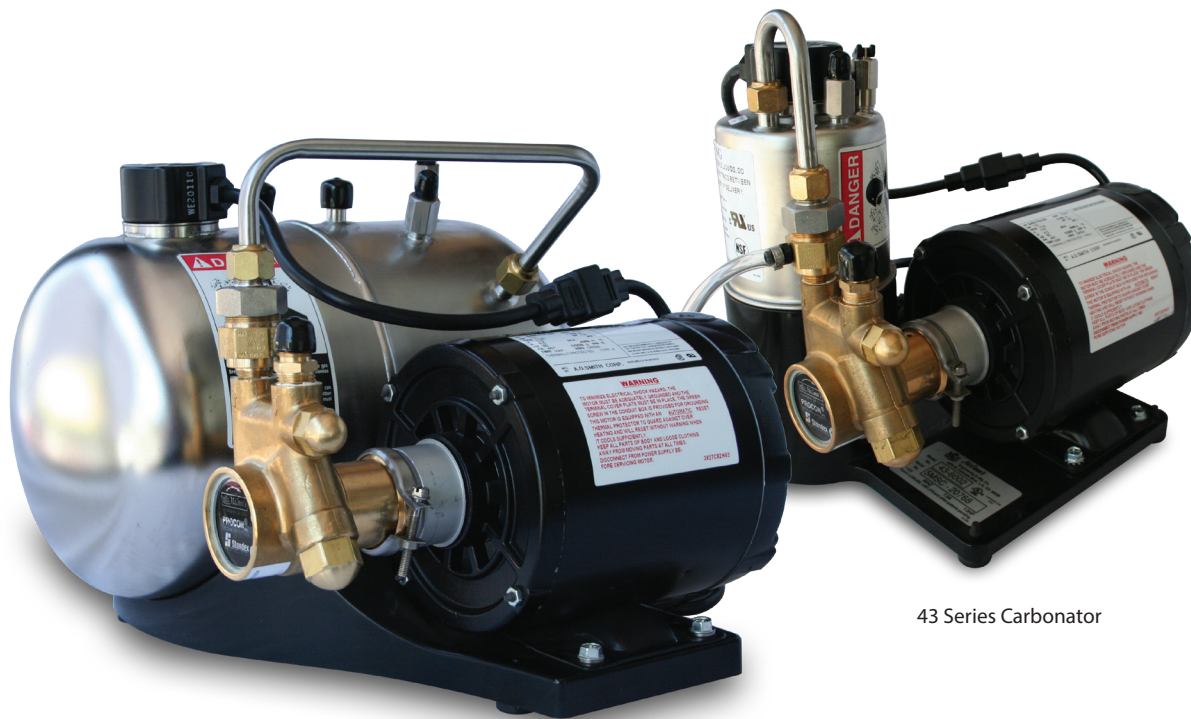

"Big Mac" E-Series Carbonator

43 Series Carbonator

Standard Features

- Durable rotary-vane brass water pump delivers atomized water to the carbonator tank. Includes internal 100 micron strainer and pressure relief valve.
- Diamond Brite stainless steel construction is corrosion-resistant and easily cleaned.
- Exclusive two-piece probe design reduces service time, improves diagnostics, and lowers costs. No need to shut off CO2 or water during service.
- Fully-encapsulated electronics package is easily removed for testing and service without the need to depressurize the tank.
- Specially designed probe electronics resists damage from amperage spikes for greater reliability.
- Liquid-level float assembly and heat sink probe cap ensure trouble-free operation and extend service life.
- Injection molded base with vibration isolating rubber feet provide sound insulation.
- Anderson Brass ASSE 1022-specified backflow prevention device included.
- Certified compliance with California AB-1953 & Vermont Act 193.

Warranty

- 5-year warranty on carbonator tank and liquid level probe control.



Specifications

	43 Series Carbonators	E Series Carbonators
Water Capacity	100 gph (378 lph) maximum	
Tank Capacity	32 fl. ounces (0.95 liter)	180 fl. ounces (5.3 liter)
Soda Outlets	1	2
Base	115V models have injection molded bases, 220V models have stainless steel bases	
Electrical	115V / 60 hz / 1ph and 220V / 50-60 hz / 1 ph	
Pump	100 GPH rotary-vane brass pump with internal strainer and by-pass relief	
Pressure Relief	180 PSI pressure relief valve	
Backflow Protection	Anderson Brass ASSE 1022-specified backflow prevention device	
Motor	115V models: 1/3 HP, 6.5 amps, 1725 RPM and 220V models: 1/4 HP, 2.0 amps, 1425 RPM	
Inlet/Outlet Fittings	1/4 male flare CO2 inlet, 3/8 male flare water inlet, 3/8 male flare soda water outlet(s)	
Approximate Shipping Weights	25 lbs. (11.4 kg)	28 lbs. (12.7 kg)
Carton Dimensions	13 x 14.5 x 11 in. (33 x 36.8 x 27.9 cm)	12 x 16 x 14.75 in. (30.5 x 40.6 x 37.5 cm)

Model Number	Description	Model Number	Description
43-5102	McCann's Small Carbonator, 220V 50/60hz, 32-Ounce SS tank	E400397	McCann's Big Mac Carbonator, 115V 60hz, 180-Ounce SS tank
43-6002	McCann's Small Carbonator, 115V 60hz, 32-Ounce SS tank	E200393	McCann's Big Mac Carbonator, 220V 50/60hz, 180-Ounce SS tank

Accessories	Description
16-0856	Optional Pump Saver – Automatically shuts carbonator motor off if water pressure drops below 15 PSI. Restarts unit when incoming water pressure returns to 20 PSI or more.
16-1480	Optional Wall-Mounted Shelf – For 43 Series, E200, and E400 models

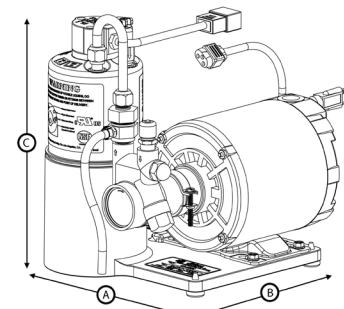

43 Series

- A 9.0" (22.9 cm)
- B 11.5" (29.2 cm)
- C 11.0" (27.9 cm)

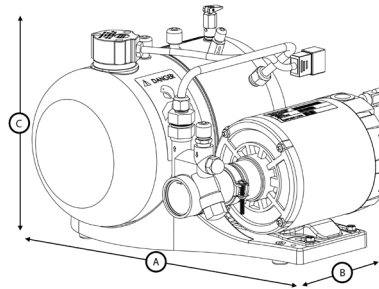

E Series

- A 14.0" (35.6 cm)
- B 13.0" (33.0 cm)
- C 10.5" (26.7 cm)

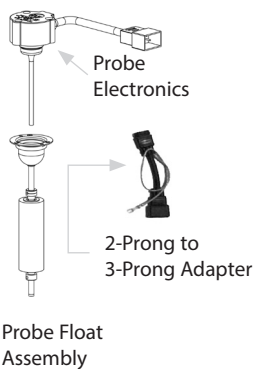

Easy to test 2-Piece Probe

1. Remove probe.
2. Pass magnetic tip of screwdriver across lower end of the tube extending from electronics package.
3. If reed switch closes, motor should start.

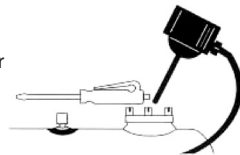

Carbonators
43 Series / E Series

Welbilt reserves the right to make changes to the design or specifications without prior notice.