



Project \_\_\_\_\_

Item # \_\_\_\_\_

Quantity \_\_\_\_\_

## Heated Zone Merchandisers

Models: HZMH-24, -30, -36, -42, -48, -54, -60  
HZMH-24D, -30D, -36D, -42D, -48D, -54D, -60D  
HZMS-24, -30, -36, -42, -48, -54, -60  
HZMS-24D, -30D, -36D, -42D, -48D, -54D, -60D

Hatco's energy-efficient Heated Zone Merchandisers safely holds hot packaged food in a smartly designed display that attracts customers. Energy costs are reduced by utilizing Spot-On® Technology - instant-on overhead elements that are off until a food product is placed on the shelf, compared to other heated merchandisers that stay on full power 100% of the time. Each shelf has multiple heat zones for maximum efficiency. Due to the intensity of the overhead heating elements, Hatco recommends food packaging that can withstand high temperatures. This warmer offers the convenience of self-serve and the efficiency of kitchen-to-server holding.

### Standard features

- Spot-On® Technology turns overhead heat on only when product is present in that zone. Base heat goes from energy saving mode to the temperature you can set
- Fast action ribbon elements will be up to temperature in less than 10 seconds
- LCD display scans and displays the various zone settings
- Hinged glass side panels swing out for easy cleaning
- Channel dividers are held in place by magnets, giving the unit more heated surface
- Standard units shipped with: an LCD controller, LED lighting above each shelf, product divider rods, hinged glass side panels, a 6' (1829 mm) cord and plug and comes standard in Designer Black



IFS anti-microbial coatings use naturally-occurring, environmentally sustainable, silver ions to help inhibit the growth of microbes on the powder coated surface. See [www.hatcocorp.com/antimicrobial-paint](http://www.hatcocorp.com/antimicrobial-paint) for more information.



For operation, location and safety information, please refer to the Installation and Operating Manual.



HZMH-24  
Horizontal single shelf



HZMH-36D  
Slant dual shelf  
shown with optional  
red LED accent  
lighting in support  
posts

### Options (available at time of purchase only)

#### Designer Colors

- Non-standard colors are non-returnable – Black standard
- Warm Red
  - Gray Granite
  - White Granite
  - Navy Blue
  - Hunter Green
  - Antique Copper

Red LED accent lighting in support posts

Wire Guards – single shelf units (not available for export)

- 24 model
- 30, 36, 42 or 48 models
- 54 or 60 models

Wire Guards – dual shelf units (not available for export)

- 24D model
- 30D, 36D, 42D or 48D models
- 54D or 60D models

Indicating Temperature Control (LED) on single shelf, HXM models only

Indicating Temperature Control (LED) on dual shelf, HXM models only

5" (127 mm) Sneeze Guards – Not compatible with optional Flip-Up Doors in same opening (customer side only)

Plexi-Glass Flip-Up Doors – Not compatible with optional Sneeze Guards in same opening (one side only)

### Accessories

Additional Stainless Steel Divider Rods



HATCO CORPORATION | P.O. Box 340500 Milwaukee, WI 53234-0500 U.S.A. | (414) 671-6350



[www.hatcocorp.com](http://www.hatcocorp.com) | [support@hatcocorp.com](mailto:support@hatcocorp.com) | [Find a Hatco Rep](#) | [Image Library](#) | [Document Library](#) | [Patents](#) | [Chat](#)



# Heated Zone Merchandisers

Models: HZMH-24, -30, -36, -42, -48, -54, -60 HZMH-24D, -30D, -36D, -42D, -48X, -54D, -60D  
 HZMS-24, -30, -36, -42, -48, -54, -60 HZMS-24D, -30D, -36D, -42D, -48X, -54D, -60D

## HORIZONTAL SHELF

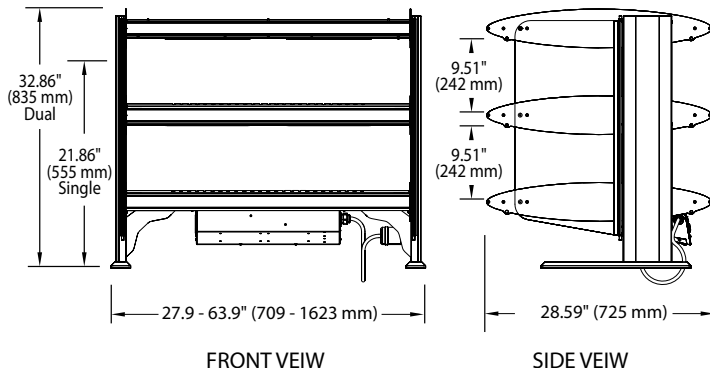

## SLANT SHELF

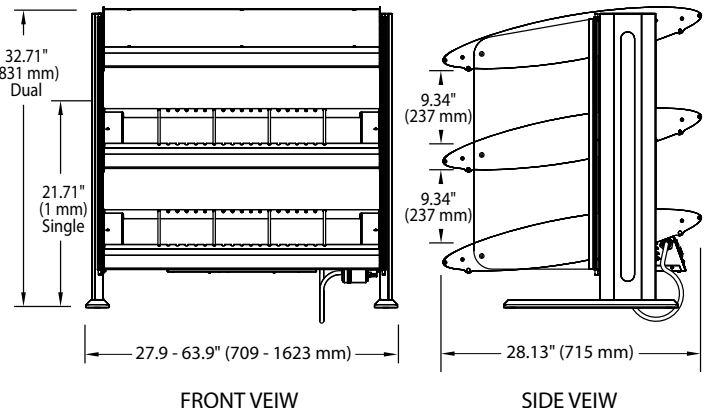

## SPECIFICATIONS

### Single Shelf – Horizontal Heated Zone Merchandisers

Model	Zones per Shelf, Divider Rods	Dimensions (W x D x H)	Usable Heated Surface per Zone (W x D)	Volts	Watts	Amps	Plug	Approx. Ship Weight
HZMH-24	2, 3	27.9" x 28.56" x 21.86" (709 x 725 x 555 mm)	20.08" x 21.75" (510 x 552 mm)	120	750	6.3	NEMA 5-15P	125 lbs. (57 kg)
HZMH-30	4, 4	33.9" x 28.56" x 21.86" (861 x 725 x 555 mm)	12.37" x 21.75" (3140 x 552 mm)	120	1350	11.3	NEMA 5-15P	141 lbs. (64 kg)
HZMH-36	4, 4	39.9" x 28.56" x 21.86" (1013 x 725 x 555 mm)	15.37" x 21.75" (390 x 552 mm)	120	1400	11.7	NEMA 5-15P	159 lbs. (72 kg)
HZMH-42	4, 6	45.9" x 28.56" x 21.86" (1166 x 725 x 555 mm)	18.32" x 21.75" (465 x 552 mm)	120	1450	12.1	NEMA 5-20P	172 lbs. (78 kg)
HZMH-48	4, 6	51.9" x 28.56" x 21.86" (1318 x 725 x 555 mm)	21.37" x 21.75" (543x 552 mm)	120	1500	12.5	NEMA 5-20P	182 lbs. (83 kg)
HZMH-54	6, 6	57.9" x 28.56" x 21.86" (1471 x 725 x 555 mm)	15.82" x 21.75" (402 x 552 mm)	120	2100	17.5	NEMA 5-30P	202 lbs. (923 kg)
HZMH-60	6, 9	63.9" x 28.56" x 21.86" (1623 x 725 x 555 mm)	17.84" x 21.75" (453 x 552 mm)	120	2150	17.9	NEMA 5-30P	216 lbs. (98 kg)

### Dual Shelf – Horizontal Heated Zone Merchandisers

Model	Zones per Shelf, Divider Rods	Dimensions (W x D x H)	Usable Heated Surface per Zone (W x D)	Volts	Watts	Amps	Plug	Approx. Ship Weight
HZMH-24D	4, 6	27.9" x 28.56" x 32.86" (709 x 725 x 835 mm)	20.08" x 21.75" (510 x 552 mm)	120	1500	12.5	NEMA 5-20P	176 lbs. ( 80 kg)
HZMH-30D	8, 8	33.9" x 28.56" x 32.86" (861 x 725 x 835 mm)	12.37" x 21.75" (3140 x 552 mm)	120/208-240	2700	11.3	NEMA L14-20P	204 lbs. ( 934 kg)
HZMH-36D	8, 8	39.9" x 28.56" x 32.86" (1013 x 725 x 835 mm)	15.37" x 21.75" (390 x 552 mm)	120/208-240	2800	11.7	NEMA L14-20P	228 lbs. (1032 kg)
HZMH-42D	8, 12	45.9" x 28.56" x 32.86" (1166 x 725 x 835 mm)	18.32" x 21.75" (465 x 552 mm)	120/208-240	2900	12.1	NEMA L14-20P	246 lbs. (112 kg)
HZMH-48D	8, 12	51.9" x 28.56" x 32.86" (1318 x 725 x 835 mm)	21.37" x 21.75" (543x 552 mm)	120/208-240	3000	12.6	NEMA L14-20P	265 lbs. (120 kg)
HZMH-54D	12, 12	57.9" x 28.56" x 32.86" (1471 x 725 x 835 mm)	15.82" x 21.75" (402 x 552 mm)	120/208-240	4200	17.6	NEMA L14-30P	308 lbs. (140 kg)
HZMH-60D	12, 18	63.9" x 28.56" x 32.86" (1623 x 725 x 835 mm)	17.84" x 21.75" (453 x 552 mm)	120/208-240	4300	18.0	NEMA L14-30P	331 lbs. (150 kg)

HATCO CORPORATION | P.O. Box 340500 Milwaukee, WI 53234-0500 U.S.A. | (414) 671-6350



[www.hatcocorp.com](http://www.hatcocorp.com) | [support@hatcocorp.com](mailto:support@hatcocorp.com) | [Find a Hatco Rep](#) | [Image Library](#) | [Document Library](#) | [Patents](#) | [Chat](#)



# Heated Zone Merchandisers

Models: HZMH-24, -30, -36, -42, -48, -54, -60 HZMH-24D, -30D, -36D, -42D, -48X, -54D, -60D  
HZMS-24, -30, -36, -42, -48, -54, -60 HZMS-24D, -30D, -36D, -42D, -48X, -54D, -60D

## SPECIFICATIONS

### Single Shelf — Slant Heated Zone Merchandisers

Model	Zones per Shelf, Divider Rods	Dimensions (W x D x H)	Usable Heated Surface per Zone (W x D)	Volts	Watts	Amps	Plug	Approx. Ship Weight
HZMS-24	2, 3	27.9" x 28.56" x 21.71" (709 x 725 x 551 mm)	20.08" x 21.75" (510 x 552 mm)	120	750	6.3	NEMA 5-15P	120 lbs. (55 kg)
HZMS-30	4, 4	33.9" x 28.56" x 21.71" (861 x 725 x 551 mm)	12.37" x 21.75" (3140 x 552 mm)	120	1350	11.3	NEMA 5-15P	145 lbs. (66 kg)
HZMS-36	4, 4	39.9" x 28.56" x 21.71" (1013 x 725 x 551 mm)	15.37" x 21.75" (390 x 552 mm)	120	1400	11.7	NEMA 5-15P	159 lbs. (72 kg)
HZMS-42	4, 6	45.9" x 28.56" x 21.71" (1166 x 725 x 551 mm)	18.32" x 21.75" (465 x 552 mm)	120	1450	12.1	NEMA 5-20P	172 lbs. (78 kg)
HZMS-48	4, 6	51.9" x 28.56" x 21.71" (1318 x 725 x 551 mm)	21.37" x 21.75" (543x 552 mm)	120	1500	12.5	NEMA 5-20P	187 lbs. (85 kg)
HZMS-54	6, 6	57.9" x 28.56" x 21.71" (1471 x 725 x 551 mm)	15.82" x 21.75" (402 x 552 mm)	120	2100	17.5	NEMA 5-30P	202 lbs. (923 kg)
HZMS-60	6, 9	63.9" x 28.56" x 21.71" (1623 x 725 x 551 mm)	17.84" x 21.75" (453 x 552 mm)	120	2150	17.9	NEMA 5-30P	216 lbs. (98 kg)

### Dual Shelf — Slant Heated Zone Merchandisers

Model	Zones per Shelf, Divider Rods	Dimensions (W x D x H)	Usable Heated Surface per Zone (W x D)	Volts	Watts	Amps	Plug	Approx. Ship Weight
HZMS-24D	4, 6	27.9" x 28.56" x 32.71" (709 x 725 x 831 mm)	20.08" x 21.75" (510 x 552 mm)	120	1500	12.5	NEMA 5-20P	176 lbs. ( 80 kg)
HZMS-30D	8, 8	33.9" x 28.56" x 32.71" (861 x 725 x 831 mm)	12.37" x 21.75" (3140 x 552 mm)	120/208-240	2700	11.3	NEMA L14-20P	209 lbs. ( 95 kg)
HZMS-36D	8, 8	39.9" x 28.56" x 32.71" (1013 x 725 x 831 mm)	15.37" x 21.75" (390 x 552 mm)	120/208-240	2800	11.7	NEMA L14-20P	223 lbs. (101 kg)
HZMS-42D	8, 12	45.9" x 28.56" x 32.71" (1166 x 725 x 831 mm)	18.32" x 21.75" (465 x 552 mm)	120/208-240	2900	12.1	NEMA L14-20P	248 lbs. (112 kg)
HZMS-48D	8, 12	51.9" x 28.56" x 32.71" (1318 x 725 x 831 mm)	21.37" x 21.75" (543x 552 mm)	120/208-240	3000	12.6	NEMA L14-20P	263 lbs. (119 kg)
HZMS-54D	12, 12	57.9" x 28.56" x 32.71" (1471 x 725 x 831 mm)	15.82" x 21.75" (402 x 552 mm)	120/208-240	4200	17.6	NEMA L14-30P	298 lbs. (135 kg)
HZMS-60D	12, 18	63.9" x 28.56" x 32.71" (1623 x 725 x 831 mm)	17.84" x 21.75" (453 x 552 mm)	120/208-240	4300	18.0	NEMA L14-30P	332 lbs. (151 kg)

### CORD LOCATION

Left rear corner, toward server side.

### PLUG CONFIGURATIONS

NEMA 5-15P

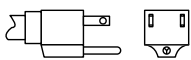

NEMA 5-20P

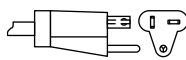

NEMA 5-30P

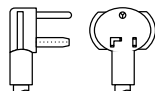

NEMA L14-20P



NEMA L14-30P

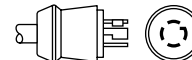

### PRODUCT SPECS

#### Heated Zone Merchandisers

The Heated Zone Merchandiser Warmers shall be a model ... as manufactured by the Hatco Corporation, Milwaukee, WI 53234 U.S.A.

The warmer shall be rated at ... watts, ... volts, and be ... inches (millimeters) in overall width. It shall consist of a thermostatically-controlled heated base, infrared heat from above, hinged glass side panels and LED display lights. The merchandiser shall

have LED lighting, fast heating infrared ribbon elements and will have a cord with plug attached.

Accessories shall include additional stainless steel dividers rods.

Warranty consists of 24/7 parts and service assistance (US and Canada only).

HATCO CORPORATION

P.O. Box 340500 Milwaukee, WI 53234-0500 U.S.A. | (414) 671-6350



[www.hatcocorp.com](http://www.hatcocorp.com)

[support@hatcocorp.com](mailto:support@hatcocorp.com)

[Find a Hatco Rep](#)

[Image Library](#)

[Document Library](#)

[Patents](#)

[Chat](#)