

# The Hatco Holdi

## PLATE WARMERS

Keep your food items warmer for extended periods with Plate Warmers. Using a heated air cabinet system, the warmer holds easily accessible pre-heated serving plates, as serving hot food on pre-heated plates is guaranteed to ensure customer satisfaction and a better customer experience!

- Doorless, open design allows for easy retrieval, loading and cleaning
- Can hold 25 plates up to 12" (305 mm) in diameter
- Feature a covered digital temperature control with an adjustable range of 104°F to 122°F (40°C to 50°C)
- Energy-efficient LED lighting illuminates the interior from the top
- Models are available as countertop, built-in or wall-mounted with the ability to daisy chain up to three units



PWB-12  
in standard  
Stainless Steel



PWC-12  
in optional  
Designer Black

## FLAV-R-FRESH® HUMIDIFIED IMPULSE DISPLAY CABINETS

Get the best of both worlds — a holding and a display cabinet wrapped into one with Flav-R-Fresh® Humidified Impulse Display Cabinets. The cabinet's controlled heat and humidity provide the best environment for holding your products, while energy-efficient LED lighting and tempered glass make showcasing food a breeze.

- Separate heat and humidity controls keep crisp foods crisp and moist foods moist
- Electronic controls monitor cabinet temperature
- Small footprint takes up minimal counter space
- Models are available with one or two doors and with revolving or stationary display racks



FDWD-2  
with accessory  
rotating 4-tier circle  
rack, accessory food  
pans and optional sign  
holders (signs shown  
not available)

### DID YOU KNOW?

*Impulse buying occurs more often when consumers can see and feel a product.*

*This type of sale makes up 80% of all impulse buys.*

# ng & Display Fix



FSD-1 with accessory 3-tier pan rack and food pans



FSDT-2 in optional Designer Black with accessory rotating 4-tier circle rack, food pans and 4" (102 mm) legs

## FLAV-R-SAVOR® HUMIDIFIED HOLDING & DISPLAY CABINETS

Showcase your food like a pro with Flav-R-Savor® Humidified Holding & Display Cabinets. Balancing a precise combination of controlled heat and humidity to keep hot foods fresh and at safe serving temperatures, while a quick recovery heating system and even cabinet temperatures mean no pesky "hot spots" and ruined food, the Flav-R-Savor reduces waste and maintains the high product quality you need to satisfy your customers.

- Tempered glass sides and door(s) provide full-view display and maximum heat retention
- Energy-efficient LED lighting showcases food products
- Low-water protection prevents heating element burnout and alerts operator to low-water condition
- Models are available with one or two doors and with revolving or stationary display racks



## DECORATIVE KIT FOR FDWD, FSD, FSDT MODELS ONLY

Transform your Flav-R-Savor® Holding & Display Cabinets and Flav-R-Fresh® Humidified Impulse Display Cabinets into a designer merchandiser with a variety of simple accessory additions. This decorative kit is the perfect way to create a new look and feel to your décor.

- The curved hinged header allows easy access to controls and water fill cup, and gives a great area to brand your food product with a magnetic sign
- The base skirt, available in flat or curved panels for the front and/or back of the unit, completes the transformation and provides an additional branding area.
- Signs (not included) can be decals or magnetic



FSDT-1 in optional Designer Black with accessory rotating 4-tier circle rack, food pans and full Decorative Kit (signs shown not available)

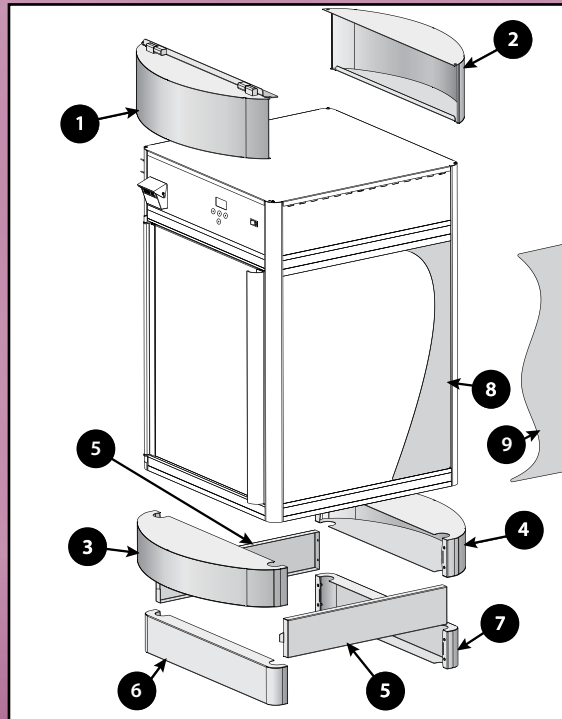

### Racks For FDWD Models

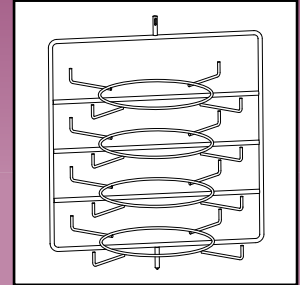

4-Tier Circle Rack  
FDWD4TCRR  
[Max. 15" (381 mm) dia. pans]  
[3¼" (83 mm) between tiers]

### Racks For FSDT Models

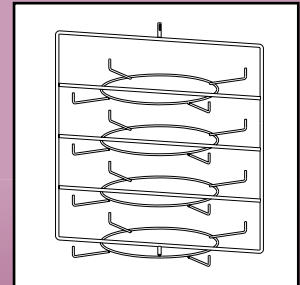

4-Tier Circle Rack  
FSDT4TCR  
[Max. 19" (483 mm) dia. pans]  
[4⅝" (117 mm) between tiers]

## Racks For FSD Models

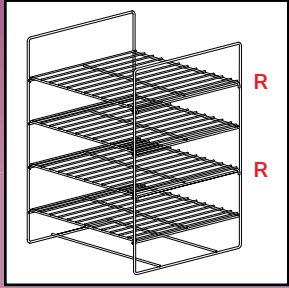

**4-Shelf Multi-Purpose Rack  
FDW4SMP**  
[Max. 18" x 13" (457 x 330 mm)]  
- Half-size sheet pans only fit  
FDWD-2, -2X models  
[3¾" (95 mm) between shelves]

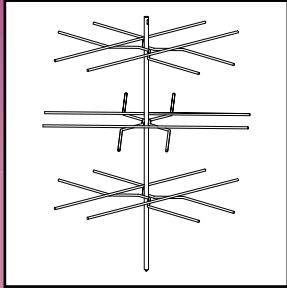

**3-Tier Pretzel Tree  
FDW3TPT**  
[5⅞" (149 mm) between tiers]

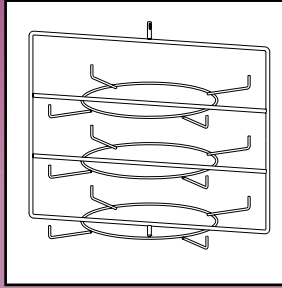

**3-Tier Circle Rack  
FSD3TCR**  
[4⅝" (117 mm) between tiers]

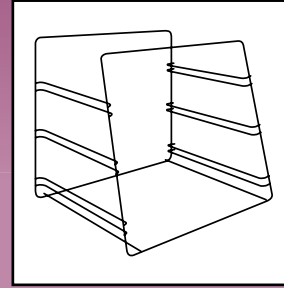

**3-Tier Pan Rack  
FSD3TPR**  
[3½" (89 mm) between tiers]

## R Removable Shelves

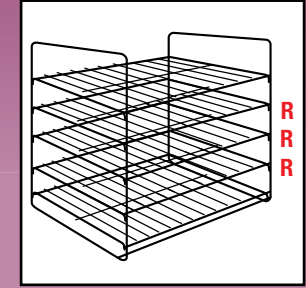

**5-Shelf Multi-Purpose Rack  
FSD5SMP**  
[2½" (64 mm) between shelves]

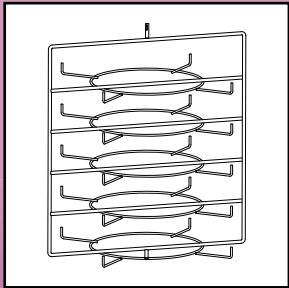

**5-Tier Circle Rack  
FSDT5TCR**  
[Max. 19" (483 mm) dia. pans]  
[3⅞" (98 mm) between tiers]

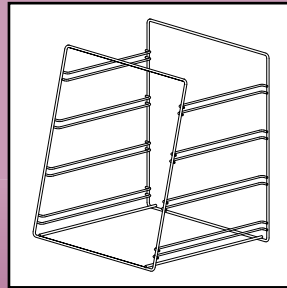

**4-Tier Pan Rack  
FSDT4TPR**  
[Max. 18" x 13" (457 x 330 mm)]  
Half-Size Sheet Pans]  
[3½" (89 mm) between tiers]

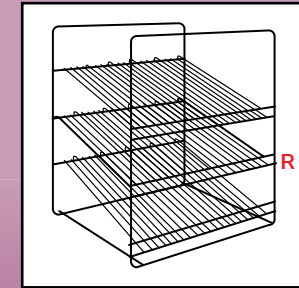

**3-Shelf Angle Rack  
FSDT3SAR**  
[3½" (89 mm) between shelves]

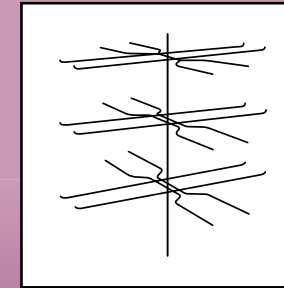

**3-Tier Pretzel Tree  
FSDT3TPT**  
[5⅞" (149 mm) between tiers]

## R Removable Shelves

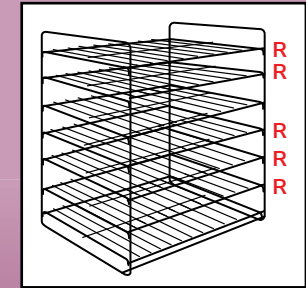

**7-Shelf Multi-Purpose Rack  
FSDT7SMP**  
[Max. 18" x 13" (457 x 330 mm)]  
Half-Size Sheet Pans]  
[2½" (64 mm) between shelves]