

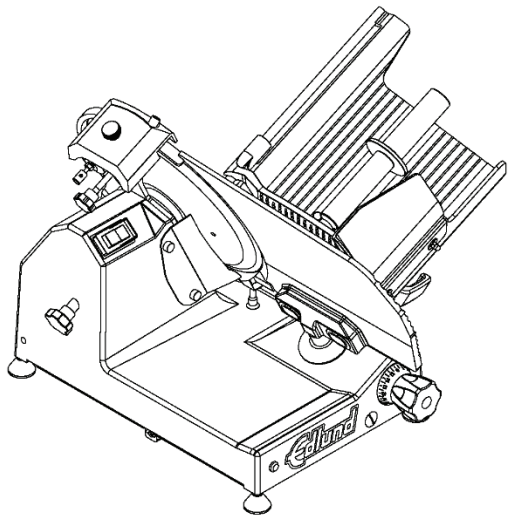

Edlund PRO Series Slicers

OPERATING AND MAINTENANCE MANUAL

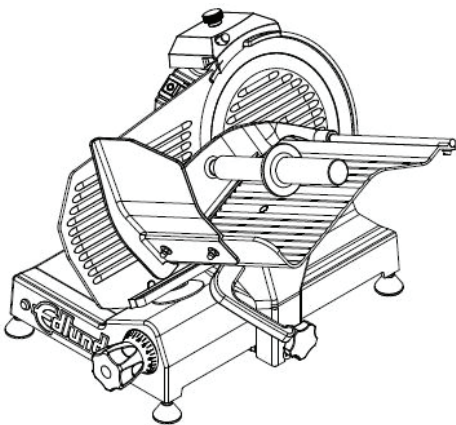

MODELS: EDV-9 EDV-10C EDV-12C EDV-12M

TABLE OF CONTENTS

SECTION. 1 - INFORMATION ON THE SLICER	pg. 4
1.1 - Safety precautions	
1.2 - Safety systems installed in the slicer	
1.2.1 - Mechanical safety system	
1.2.2 - Electrical safety system	
1.3 - Specifications of the slicer	
1.3.1 - General description	
1.3.2 - Construction features	
1.3.3 - Slicer components	
SECTION. 2 - TECHNICAL DATA	pg. 7
2.1 - Overall dimensions, weight, characteristics	
SECTION. 3 - SUPPLY OF THE SLICER	pg. 8
3.1 - Packaging of the slicer	
3.2 - Package check upon arrival	
SECTION. 4 - INSTALLATION	pg. 9
4.1 - Setting up of the slicer	
4.2 - Electric connection	
4.2.1 - Slicer equipped with a single-phase motor	
4.3 - 110 V Electrical diagram	
4.3.1 - Arrangement of the single-phase electric circuit	
4.4 - Operation check	
SECTION. 5 - OPERATING OF THE SLICER	pg. 10
5.1 - Controls	
5.2 - Loading and slicing of food	
5.3 - Sharpening the blade	
SECTION. 6 - CLEANING	pg. 13
6.1 - General features	
6.2 - Slicer cleaning procedure	
6.2.1 - Meat hopper cleaning	
6.2.2 - Blade, blade guard and ring cleaning	
6.2.3 - Cleaning of the sharpener	
6.2.4 - Cleaning of the deflector	
SECTION. 7 - MAINTENANCE AND USEFUL ADVICE	pg. 15
7.1 - General features	
7.2 - Belt	
7.3 - Feet	
7.4 - Power supply cord	
7.5 - Blade	
7.6 - Grinding stones	
7.7 - Lubrication of sliding guides	
7.8 - The push-button cover	

INTRODUCTION

This manual will help you set up and safely operate your new Edlund Edvantage Manual Slicer. Careful adherence to the safety and operating instructions in this manual will ensure many years of productive use. Please let us know of any questions you may have. To expedite your call, please have your serial number and/or order number handy. For technical assistance, please call Toll-Free 1-800-772-2126 and one of our Technical Support Representatives will be happy to help you.

Conventions used in this manual:



WARNING

(ORANGE)

THIS INDICATES A POTENTIALLY HAZARDOUS SITUATION, WHICH, IF NOT AVOIDED, COULD RESULT IN DEATH OR SERIOUS INJURY.



CAUTION

(YELLOW)

THIS INDICATES A POTENTIALLY HAZARDOUS SITUATION, WHICH, IF NOT AVOIDED, MAY RESULT IN MINOR OR MODERATE INJURY.

SECTION. 1 - INFORMATION ON THE SLICER

1.1 - SAFETY PRECAUTIONS

⚠ WARNING

- Before starting cleaning and maintenance, disconnect the slicer plug from the power outlet.
- Assess the residual risks carefully when protection devices are removed to carry out cleaning and maintenance.
- Cleaning and maintenance require great concentration and should only be performed after proper training.
- Regular inspection of the electric supply cords is necessary; a worn-out or damaged cord can expose users to great electric shock hazard.
- If the slicer shows malfunctions, it is recommended not to use it. For repairs; please call Edlund Company: 1-800-772-2126
- Do not use in the following cases:
 - If the slicer has been tampered with by non-authorized personnel;
 - If some parts have been substituted by non-original spare parts;
 - If the instructions contained in this manual are not followed accurately;
 - If the slicer is not cleaned and oiled with the right products.

⚠ CAUTION

- The slicer must be operated only by highly qualified people who are fully aware of the safety measures described in this manual.
 - Operator training is to be provided in advance.
 - Although the slicer is equipped with safety devices in the dangerous areas, it is recommended not to touch the blade or moving components.
 - Do not use the slicer for frozen products, meat and fish with bones and any products other than food.
 - Do not use the slicer without the help of the meat pusher, when the meat is nearly finished.
 - Do not place yourself in a dangerous position, the blade may cause injuries.
-

1.2 - SAFETY SYSTEMS INSTALLED IN THE SLICER

1.2.1 - Mechanical safety system

The safety system includes (see section 1.3.3):

- Blade guard;
- Ring;
- Cover;
- Meat pusher;
- Meat pusher knob with ring nut and spacer;
- Hand cover on the meat hopper;
- Carriage only removable when the thickness gauge is set in the “0” position, at the end of its travel and towards the operating side.

1.2.2 - Electrical safety system

The slicer is equipped with:

- A micro-switch which stops the slicer in case the tie rod for blade guard is removed (*see FIG. no. 1*); the micro-switch prevents the slicer from restarting if the guard has not been set in the switch-off position.
- A relay in the control box which requires the restarting of the slicer when a power outage occurs.

1.3 - SPECIFICATIONS OF THE SLICER

1.3.1 - General Description

This unit has been designed and manufactured to guarantee:

- The highest degree of safety in functioning, cleaning and maintenance;
- The highest sanitation standards due to an accurate choice of materials and smooth design of the slicer components to allow for easy disassembly and total cleanliness;
- The greatest accuracy in cutting food thanks to a cam mechanism;
- Solidity and stability of components;

1.3.2 - Construction Features

The professional slicers are made of an aluminum alloy (Peraluman Mg5) treated by anodic oxidation. This procedure guarantees high hygienic standards and resistance to acids, salts and oxidation processes.

The blade is made of chromium plated steel 100Cr6; it is ground and hardened to guarantee an accurate and sharp cut of products and can be re-sharpened with the built-in sharpening stones. The other components of the slicer are made of ABS, LEXAN, PLEXIGLASS and stainless steel AISI 430 or 304.

ITEMS NOT PICTURED IN FIG. #1		
Model	Desc.	part #
EDV-9	BELT, MOTOR-BLADE	BE002
EDV-10C	BELT, MOTOR-BLADE	BE003
EDV-12C/12M	BELT, MOTOR-BLADE	BE004
EDV-9	SEAL RING	SE001
EDV-10C	NO SEAL RING ON THIS UNIT	
EDV-12C/12M	SEAL RING	SE002
EDV-9	WASHER FOR HAND GUARD	WA010
EDV-10C/12C	WASHER FOR HAND GUARD	WA009
EDV-12M	WASHER FOR HAND GUARD	WA008
EDV-9/10/12	NUTS FOR HAND GUARD	N142
EDV-9/10/12	CORD, POWER	C705
EDV-9	CAPACITOR	C704
EDV-10C/12C	CAPACITOR	C700
EDV-12	CAPACITOR	C701
EDV-9/10/12	THERMAL BREAKER	BR043
EDV-9	MOTOR	M213
EDV-10C/12C	MOTOR	M214
EDV-12	MOTOR	M215

1.3.3 - Slicer components

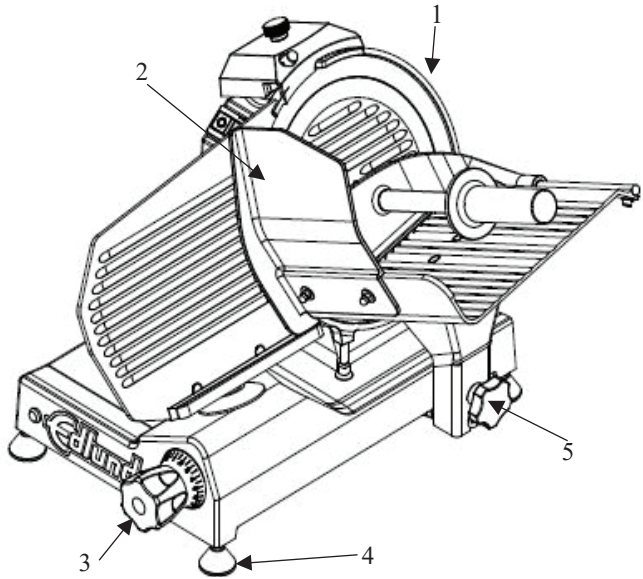

Sharpener Assembly:
 EDV-9 = SH014
 EDV-10C= SH011
 EDV-12C= SH012
 EDV-12M= SH013

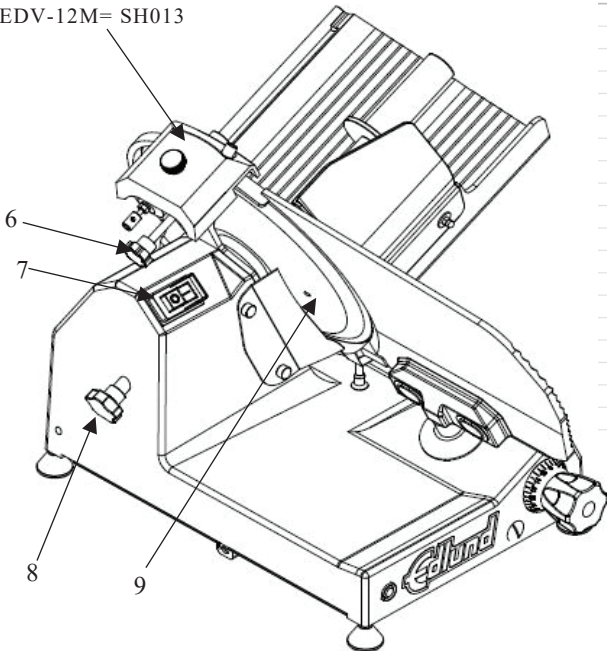

LEGEND:

#	Model	Desc.	part #
1	EDV-9	Ring	R193
1	EDV-10	Ring	R190
1	EDV-12C	Ring	R191
1	EDV-12M	Ring	R192
2	EDV-9/10C	Hand guard/cover	CV110
2	EDV-12C	Hand guard/cover	CV111
2	EDV-12M	Hand guard/cover	CV112
3	All	Dial knob	KN06
4	All	Feet	F330
5	All	Carriage locking knob	KN05
6	EDV-9/10C	Sharpener locking knob	KN03
6	EDV-12C/12M	Sharpener locking knob	KN04
7	All	Push button panel	S950
8	EDV-9	Blade guard tie rod	KN08
8	EDV-10C/12C	Blade guard tie rod	KN02
8	EDV-12M	Blade guard tie rod	KN01
9	EDV-9	Blade	BL039
9	EDV-10C	Blade	BL040
9	EDV-12C/12M	Blade	BL041

FIG. no. 1 - General view of the slicer

SECTION. 2 - TECHNICAL DATA

2.1 - OVERALL DIMENSIONS, WEIGHT, CHARACTERISTICS

FIG. no. 2 - Drawings of the overall dimensions

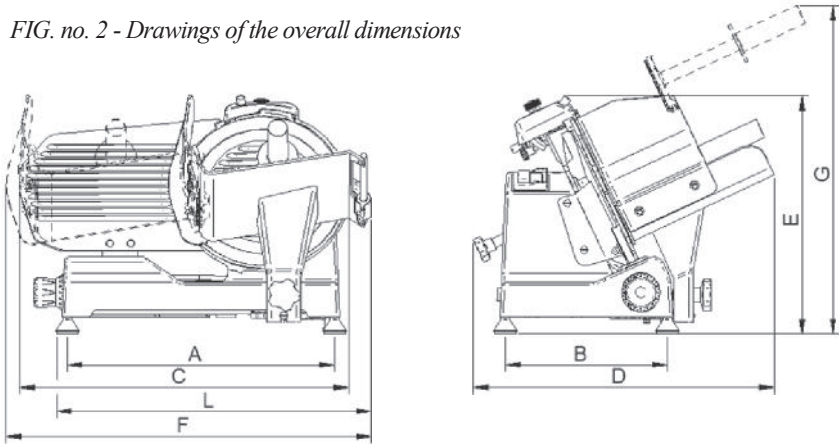

TAB. no. 1 - OVERALL DIMENSIONS AND TECHNICAL CHARACTERISTICS.

MODEL	Unit	EDV-9	EDV-10C	EDV-12C	EDV-12
Ø Blade	in	9	10	12	12
Motor	W / Hp	147 / 1/4	250 / 1/3	250 / 1/3	370 / 1/2
Power Supply	1Ph	110V / 60Hz			
Cut thickness	in	.5	.5	.5	.5
Run of carriage	in	9.7	9.7	9.7	11.2
Hopper size	in	8.9 x 9.5	8.9 x 9.5	8.9 x 9.5	9.8 x 10.8
A x B	in	15.6 x 10.4	15.6 x 10.4	15.6 x 10.4	17.1 x 11.6
C x D x E	in	18.8x18.1x14.4	19.7 x 23 x 14.75	21.9 x 23.2 x 16	23.4 x 25.2 x 16.5
F x D x G	in	21.8 x 18.1 x 18.3	21.9 x 23 x 19.2	22.7 x 23.2 x 18.8	24.8 x 25.2 x 21.5
L	in	19.3	18.4	18.4	20.9
X	in	8.6	8.8	8.8	9.8
Y	in	5.5	6.1	7.4	7.3
H	in	7.0	7.6	8.8	8.9
W	in	6.7	7	8.2	8.3
Net weight	lbs	33	43	47.5	53
Noise level	dB	< 60	< 60	< 60	< 60

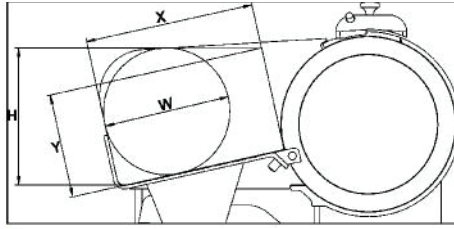

WARNING

- Electrical features of the slicer are shown in the rating plate placed on the back side of the machine.
- Before connecting the slicer to the electric system see section 4.2 Electric Connection

SECTION. 3 - SUPPLY OF THE SLICER

3.1 - PACKAGING OF THE SLICER

Slicers are accurately packed and then shipped from our warehouses; the package includes:

- a) A strong cardboard box;
- b) The slicer;
- c) Two cardboard filling inserts to keep the slicer stable;
- d) This manual;
- e) An oil bottle;

a)

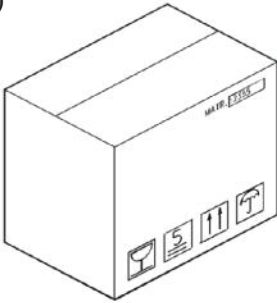

b)

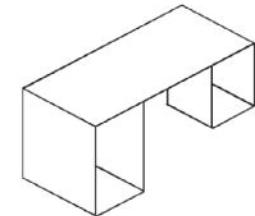
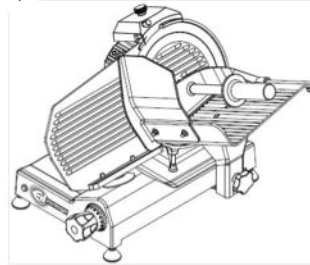

c)

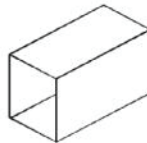

d)



e)



FIG. no. 3 - Description of the package

3.2 - PACKAGE CHECK UPON ARRIVAL

If no external damage is evident on the package upon its arrival, open it and verify that all the components are inside (*see FIG. no. 3*). If the package has suffered from rough handling, bumps or crashes, the carrier must be informed about any damage. Do not overturn the package!! When the package is transported, make sure, the box is lifted by the 4 corners (parallel to the ground).

SECTION. 4 - INSTALLATION

4.1 - SETTING UP OF THE SLICER

⚠ CAUTION

- The slicer must be installed on a working table suitable for the slicer's overall dimensions shown in *Table no. 1* (according to the model); therefore, it must be adequately large, well levelled, dry, smooth, resistant, stable and placed at a height of 31.5 in. from the ground.
- The machine must be installed in a room with max. 75% not saline humidity at a temperature between 41°F (+5°C) and 95°F (35°C); these conditions ensure the optimal performance of the machine

4.2 - ELECTRIC CONNECTION

4.2.1 - Slicer equipped with a single-phase motor

The slicer is equipped with a UL listing power supply cord and a plug.

Connect the slicer with a 110 Volt - 60 Herz electric circuit.

Moreover check that features on the rating plate - serial number (*FIG. no. 4*) correspond to the features shown in the consignment and delivery note.

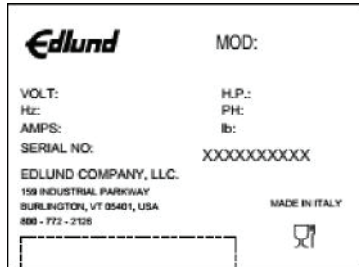

FIG. no. 4 - Rating plate - serial

4.3 - 110 V ELECTRICAL DIAGRAM

4.3.1 - Arrangement of the single-phase electric circuit

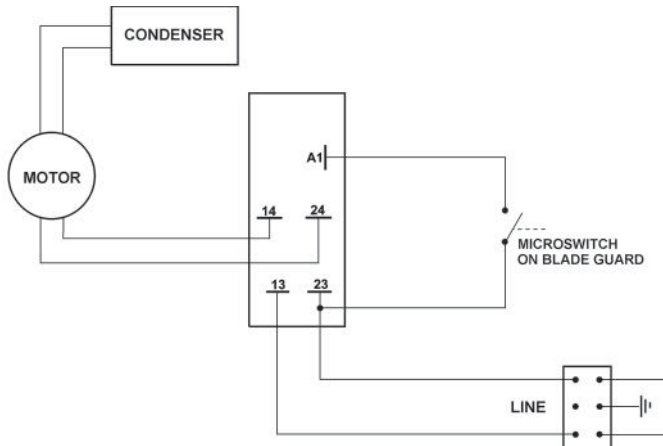

FIG. no. 5 - Single-phase electric system arrangement

4.4 - OPERATION CHECK

Before testing the slicer check that the meat hopper is blocked and then try the functioning according to the following procedure:

- 1 Push the switch-on button "I" (ON) and the switch-off button "0" (OFF);
- 2 Check the sliding of the meat hopper and meat pusher;
- 3 Check the functioning and adjustment of the plate through the dial knob;
- 4 Check the functioning of the sharpener (see section 5.3, FIG. no. 9 a-b-c);
- 5 Check that the meat hopper can be disassembled only with the dial knob set in the "0" position and that, after disassembling the machine, the knob remains in this position;
- 6 Check that the slicer stops functioning by unscrewing the tie rod for blade guard.

SECTION. 5 - OPERATING OF THE SLICER

5.1 - CONTROLS

Controls are placed on the side and top of the base as shown in the pictures below.

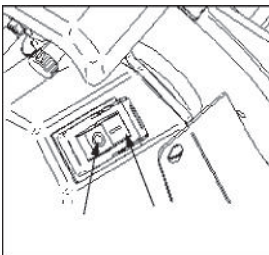

- 1 Dial knob to adjust the cutting thickness.
- 2 Switch-on button "I".
- 3 Switch-off button "0".

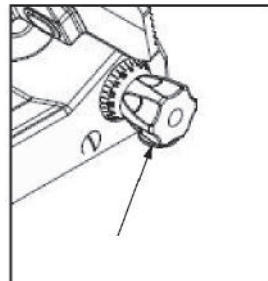

FIG. no. 6 - Position of controls

5.2 - LOADING AND SLICING OF FOOD

CAUTION

- Products to be cut must be loaded on the meat hopper only when the dial knob is set to the “0” position and pay attention to the blade and the sharp edges.
- Do not operate the slicer without food;
- Pay the maximum attention: no parts of your body should enter into contact with the blade (see FIG. no. 7);

The procedure is as follows:

- 1 Once the product has been loaded onto the meat hopper and placed against the plate, stop it with the arm provided with gripping points;
- 2 Adjust the dial knob to obtain the desired cutting thickness;
- 3 To avoid accidents, the person who is cutting must face the machine and stand correctly: put the right hand on the meat pusher, and then the left one beside the deflector (do not touch the blade); the body must be perpendicular to the working surface (see FIG. no. 8). Push the switch-on button “I”;
- 4 Smoothly push the carriage including the meat hopper, meat pusher, and stem towards the blade without exerting pressure on food with the meat pusher since they have their own force of gravity which exerts pressure on the thickness gauge. The blade will easily cut food and slices will be guided by the deflector onto the collecting plate;
- 5 Once food has been cut, set the dial knob in the “0” position and switch off the machine by setting the switch to the “0” position;
- 6 Re-sharpen the blade as soon as slices show a rough or frayed surface and cutting becomes difficult (see section 5.3).



FIG. no. 7 - Incorrect position

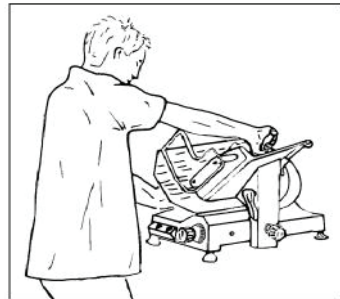

FIG. no. 8 - Correct position

5.3 - SHARPENING THE BLADE

CAUTION

Before proceeding with blade sharpening, please refer to the safety precautions (see section 1.1) to prevent injury during slicer maintenance.

The blade must be sharpened periodically and as soon as it becomes blunt; the following detailed instructions are to be carried out:

1. Disconnect power cord from power supply socket.
2. Clean the blade accurately with denatured alcohol to remove grease;
3. Unscrew the knob (1) until the sharpener (2) loosens. Lift (a) the sharpener (2) up to the locking position and rotate it 180° (b) (see FIG. no. 9a). Then let it move to the end (c) so that the blade is positioned between the two grinding stones. Lock the knob;
4. Switch-on the slicer by pushing the button “I” (ON);
5. Push the small button (3) (see FIG. no. 9b), let the blade rotate against the grinding stone for 30 to 40 sec. to produce burr on the blade edge;
6. Push buttons simultaneously for 1-2 seconds (3 and 4) and then let go of them simultaneously (see FIG. no. 9c);
7. It is recommended to clean the grinding stones after sharpening (see section 6.2.3);
8. Once sharpening has been completed, return the sharpening stones to their original setting with the reverse procedure.

NOTE: Do not prolong the burring operation beyond 1 to 2 sec. in order to prevent the dangerous twisting of the blade cutting edge.

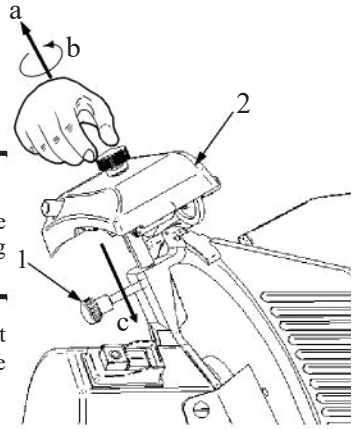

FIG. no. 9a

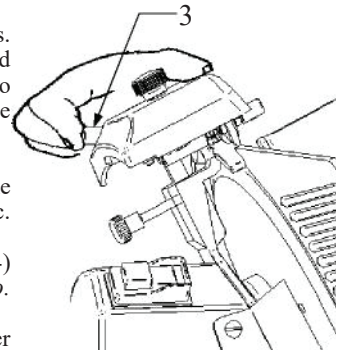

FIG. no. 9b

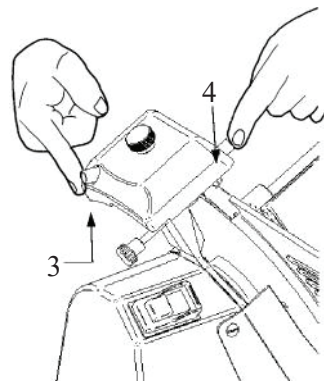

FIG. no. 9c

SECTION. 6 - CLEANING

6.1 - GENERAL FEATURES

⚠ WARNING

Before carrying out any cleaning operation it is necessary to:

- 1) Disconnect the power supply plug from the socket to isolate the slicer from the rest of the electric circuit completely;
- 2) Set the dial knob adjusting the plate to the "0" position.

⚠ CAUTION

- The slicer cleaning must be carried out at least once a day or more frequently if necessary.
- Cleaning must be extremely accurate for those parts of the slicer which are directly or indirectly in contact with food.
- The slicer must not be cleaned with water-cleaners and high-pressure jets of water, but use water and mild detergent. Do not use other detergents. Tools, brushes and other devices likely to damage the slicer's surface must not be used.
- Pay attention to residual risks due to cutting and/or sharp edges.

6.2 - SLICER CLEANING PROCEDURE

6.2.1 - Meat hopper cleaning (see FIG. no. 10)

The carriage (meat hopper, arm, stem) is easily removable:

- With the dial knob (1) set in the "0" position;
- Unscrew the carriage locking knob (2);
- Push the carriage (3) to the end of its run (a) near the dial knob until it clicks into place;
- Slide the carriage upwards (b);
- After having removed the carriage, it is possible to clean the meat hopper with hot water and mild detergent (PH 7).

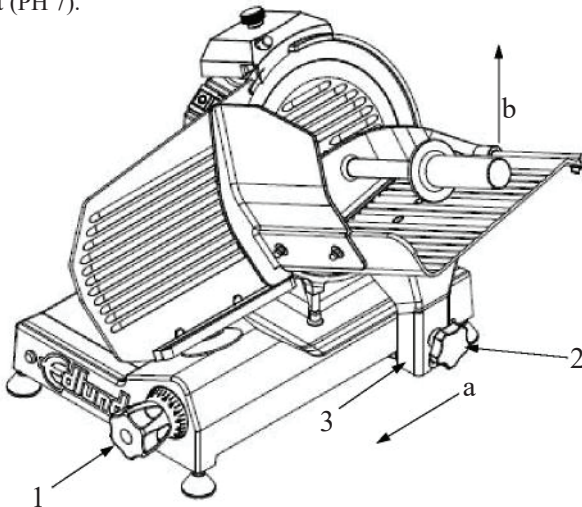

FIG. no. 10 - Release of the carriage

6.2.2 - Blade, blade guard and ring cleaning

Unscrew the knob of the tie screw (1) (see FIG. no. 11) to release the blade guard (2).

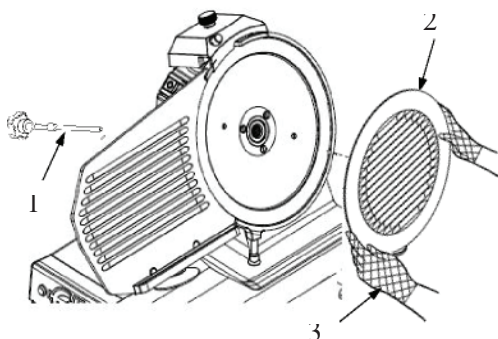

FIG. no. 11 - Release of blade guard

The blade cleaning must be carried out with cut resistant gloves (3) and a wet cloth. To clean the blade on the opposite surface, it is necessary to remove the blade (see FIG. no. 12).

The blade is to be removed as follows:

- 1) Disassemble the blade cover (see FIG. no. 11);
- 2) Remove (a) the sharpener and open the thickness plate with the dial knob to allow the plastic blade removal tool (b) to be adhered to the blade;
- 3) Loosen the 3 or 4 screws (f) (according to the model) that hold the blade in place;
- 4) Lean the plastic blade removal tool (b) on the blade to align the blade holes with the two screws (e)(d), turn the blade until it reaches the correct position;
- 5) Hand tighten the screws (e).

NOTE: The blade guard must be cleaned with hot water and mild detergent.

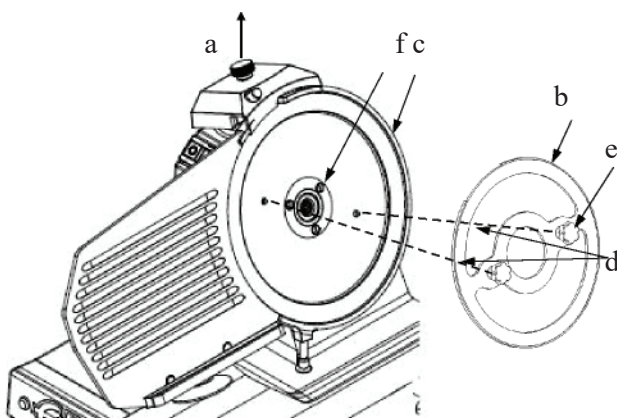

FIG. no. 12 - Placing the blade guard to remove the blade

6.2.3 - Cleaning of the sharpener

CAUTION

The sharpener cleaning operation is carried out by rubbing the grinding stones with a brush; the stones must be placed in the safety position which means that they must be turned towards the side opposite to the blade.

6.2.4 - Cleaning of the deflector

The two screws (a) locking the deflector must be unscrewed to remove it (*see FIG. no. 13*).

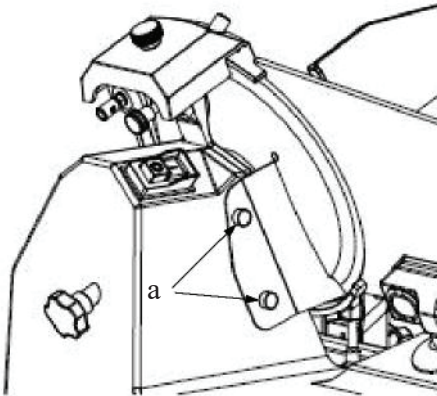

FIG. no. 13 - View of the deflector

Clean the deflector with hot water and mild detergent.

SECTION. 7 - MAINTENANCE

7.1 - GENERAL FEATURES

WARNING

Before starting maintenance, it is necessary to:

- a) Disconnect the power supply cord plug from the socket to isolate the slicer from the electric circuit completely.
- b) Place the dial knob adjusting the thickness plate in the "0" position.

7.2 - BELT

The belt should not be adjusted. If the belt needs adjustment or repair, please call Edlund Company: 1-800-772-2126

7.3 - FEET

Feet may deteriorate and lose elasticity thus reducing the stability of the slicer. In this case they must be replaced.

7.4 - POWER SUPPLY CORD

Periodically check whether the power supply cord is worn-out and, if this is the case, please call Edlund Company to have it replaced.

7.5 - BLADE

Check that the blade has not been sharpened to less than 0.4 in. (10mm) of its original diameter. To have it replaced call Edlund Company.

7.6 - GRINDING STONES

Check that the grinding stones retain their abrasive property during sharpening operations. They must be replaced periodically so they do not damage the blade; please call Edlund Company.

7.7 - LUBRICATION OF SLIDING GUIDES

From time to time pour some oil drops (from the oil bottle provided with the slicer) onto the round bar along which the carriage slides back and forth.

7.8 - THE PUSH-BUTTON COVER

If the push-button cover has been damaged, please call Edlund Company to substitute it.

PROTECT YOUR INVESTMENT

Ensure your equipment is protected under warranty

By registering at

www.edlundco.com/product-registration



WARRANTY

All Edlund products are guaranteed against defects in material and workmanship for a period of one year from date of purchase, except where specifically noted. The company's obligation under this warranty is limited to repairing or replacing without charge any part or parts found to be defective **under normal use**. If applicable, it is the responsibility of the purchaser to return the entire unit to the factory, **properly packed, transportation charges prepaid**. This warranty does not cover knives and gears on can openers. No other warranty, written or verbal, is authorized by the company. Warranty charges do not include state, federal, foreign, excise, municipal, or other sales or use taxes. All such taxes are the responsibility of the purchaser.

Carrier is responsible for merchandise in transit to you.

Edlund Company reserves the right to make changes in design or add any improvements on any product. The right is always reserved to modify our equipment because of factors beyond our control and government regulations. Charges to update equipment do not constitute a warranty charge.

The following are not covered under warranty:

1. Failure from neglect, abuse, careless handling or mis-application of unit.
2. Failure caused by improper maintenance.

Return products to:

Edlund Company, LLC, Service Department
319 Queen City Park Rd., Burlington, VT 05401, USA
An ISO 9001:2015 Company

Phone: (800) 772-2126 & (802) 862-9661 • Fax: (802) 862-4822

