

RESOLUTE  
ICE SYSTEMS



# ICH1000



Boost your production capacity with this heavy duty ice machine delivering 1,000 pounds of ice daily. Engineered for demanding professional environments, it provides a dependable supply of a fresh ice while maintaining energy-efficient operation.

## FEATURES

- Air cooled refrigeration system powered by R290 for efficient, eco-friendly performance.
- Removable air filter designed for easy maintenance.
- Integrated cleaning cycle help maintain optimal hygiene during high-demand periods.
- Intuitive digital controls interface for easy operation.
- Durable stainless-steel construction engineered to extend unit lifespan.



PARTS AND  
SERVICE



FOR  
COMPRESSOR

## SPECIFICATIONS

Power: 2,217 W - 220 V - 60 Hz

Production in 24/h: 1,000 lbs (455 kg)

Ice shape: Half-sized cube

Cube size: 9 g - 0.87<sup>in3</sup> (22 mm<sup>3</sup>)

Batch size: 400 cubes

Evaporator: 20 x 20

Condenser unit: Air

Refrigerant gas: R290

Dimensions:

Length: 23.4" (60 cm)

Width: 29.9" (76 cm)

Height: 29" (73 cm)

Net weight: 198 lb (90 kg)

Connection:   
(220 V)

Compatible with:  
IB405  
IB705

## Included accessories

- Inlet water filter
- Mounting kit
- Cartridge





# ICH1000

## FRONTAL VIEW

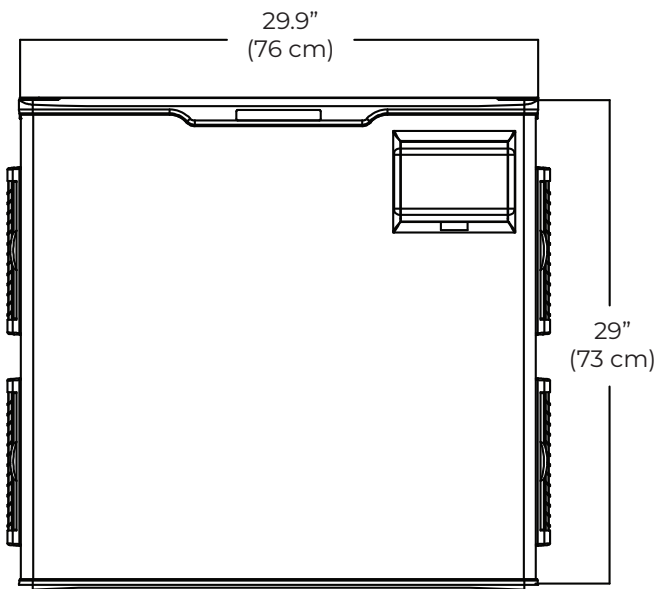

## SIDE VIEW

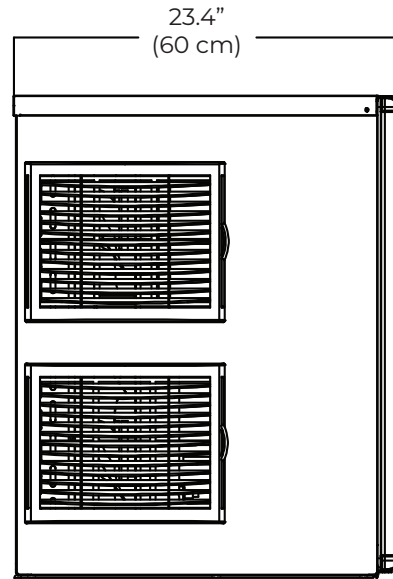

## BACK VIEW

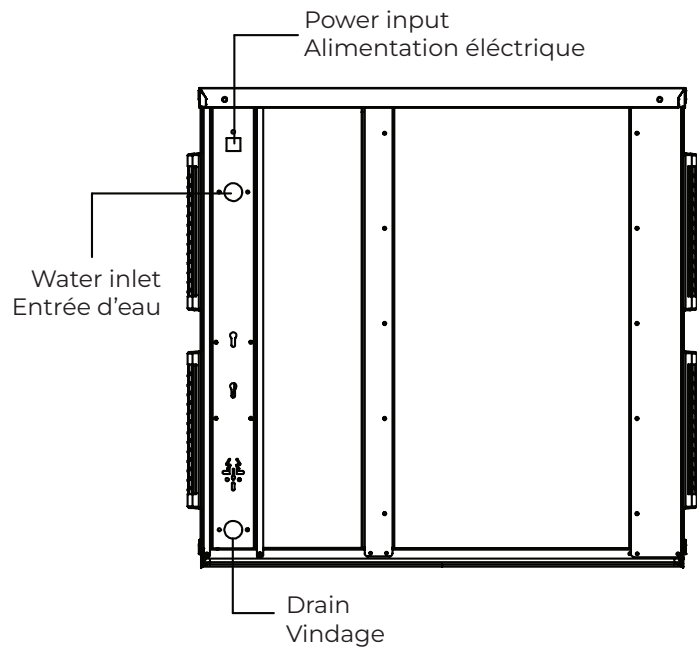

RESOLUTE  
ICE SYSTEMS



# ICH1000



Augmentez votre capacité de production grâce à cette machine à glace robuste pouvant produire 1 000 livres de glace par jour. Conçue pour les environnements professionnels les plus exigeants, elle assure un approvisionnement fiable en glace fraîche tout en maintenant une consommation d'énergie efficace.

## CARACTÉRISTIQUES

- Système de réfrigération à air utilisant le réfrigérant R290 pour une performance efficace et écologique.
- Filtre à air amovible conçu pour faciliter l'entretien.
- Cycle de nettoyage intégré aidant à maintenir une hygiène optimale lors des périodes de forte demande.
- Interface de commande numérique intuitive pour une utilisation simple et efficace.
- Construction robuste en acier inoxydable, conçue pour prolonger la durée de vie de l'appareil.



PIÈCES ET  
MAIN-D'ŒUVRE



POUR  
COMPRESSEUR

## SPÉCIFICATIONS

Puissance :	2 217 W – 220 V – 60 Hz
Production en 24 h :	1 000 lb (455 kg)
Forme de la glace :	Cube demi-format
Format du cube :	9 g – 0,87 po <sup>3</sup> (22 mm <sup>3</sup> )
Production par cycle :	400 cubes
Évaporateur :	20 x 20
Condenseur :	Air
Réfrigérant :	R290
Dimensions :	
Longueur :	23,4 po (60 cm)
Largeur :	29,9 po (76 cm)
Hauteur :	29 po (73 cm)
Poids net :	198 lb (90 kg)

Connexion :   
(220 V)

Compatible avec :  
IB445  
IB705

## Accessoires inclus

- Filtre d'entrée d'eau
- Trousse de montage
- Cartouche



RESOLUTE  
ICE SYSTEMS



# ICH1000

## VUE AVANT

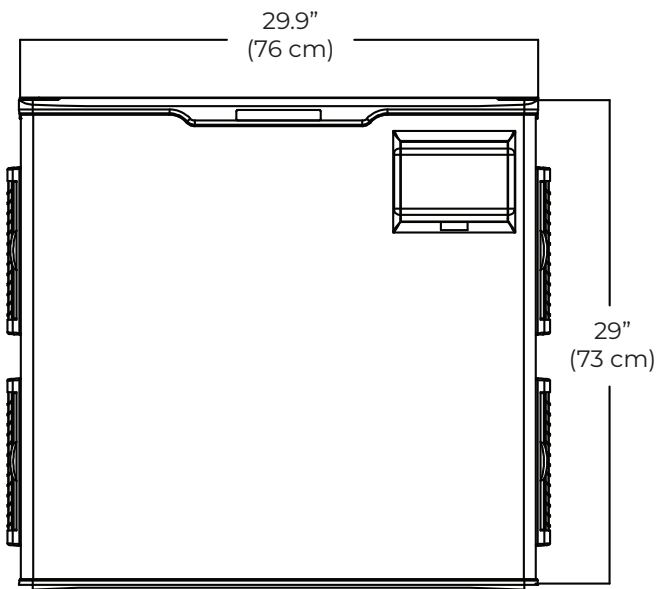

## VUE DE CÔTÉ

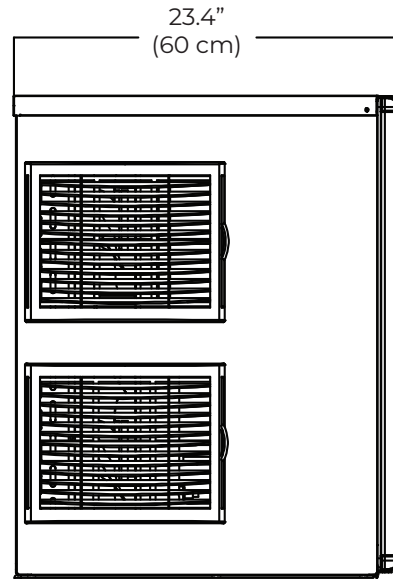

## VUE ARRIÈRE

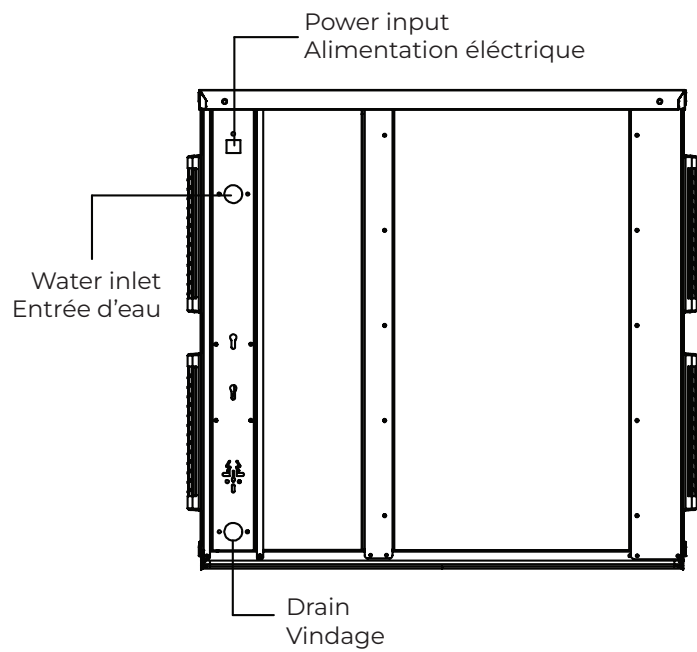



Intertek

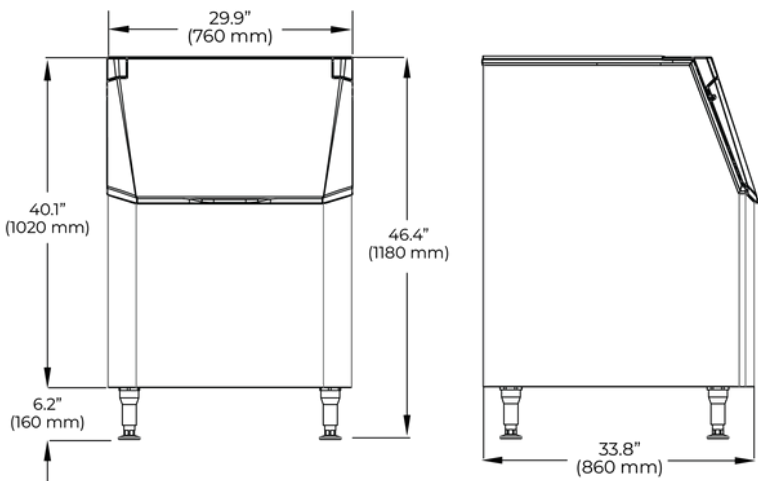

**RESOLUTE**  
ICE SYSTEMS



## ICE BIN FOR MODULAR MACHINE

### IB445

A durable and space-efficient solution designed for high-demand commercial environments. This insulated bin features stainless steel and ABS plastic construction, adjustable legs and a hook to hold the ice scoop.

#### Technical Specifications

MODEL	IB445
Ice capacity	445 lb (200 kg)
Compatible with	ICH500
Warranty	3 months
Dimensions	
Machine Dimensions	L: 29.9" (76 cm) D: 33.8" (86 cm) H: 46.4" (118 cm)
Adjustable legs	H: 6.2" (16 cm)
Shipping Dimensions	L: 32.4" (82.5 cm) D: 36.4" (92.5 cm) H: 48" (121.9 cm)
Weight	
Net weight	86 lb (39 kg)
Gross weight	97 lb (44 kg)

V.05.08.2025

